



Dongguan VitranS Automation Co.,Ltd

Telephone

+86 18027652537

Address

No.15,Chitian Dong Road,Baishi Gang,Changping Town,Dongguan City 523000

Website

www.vitranS-conveyor.com

E-mail

qingsong.xu@vitranS.cn

WORKPIECE TRAY
CONVEYOR

TRANSVERSE UNIT
CURVE UNIT

LIFT UNIT
POSITIONING UNIT

ROTATOR UNIT
CONTROL UNIT

Vitrans Automation

VT CONVEYOR SYSTEM

3.0

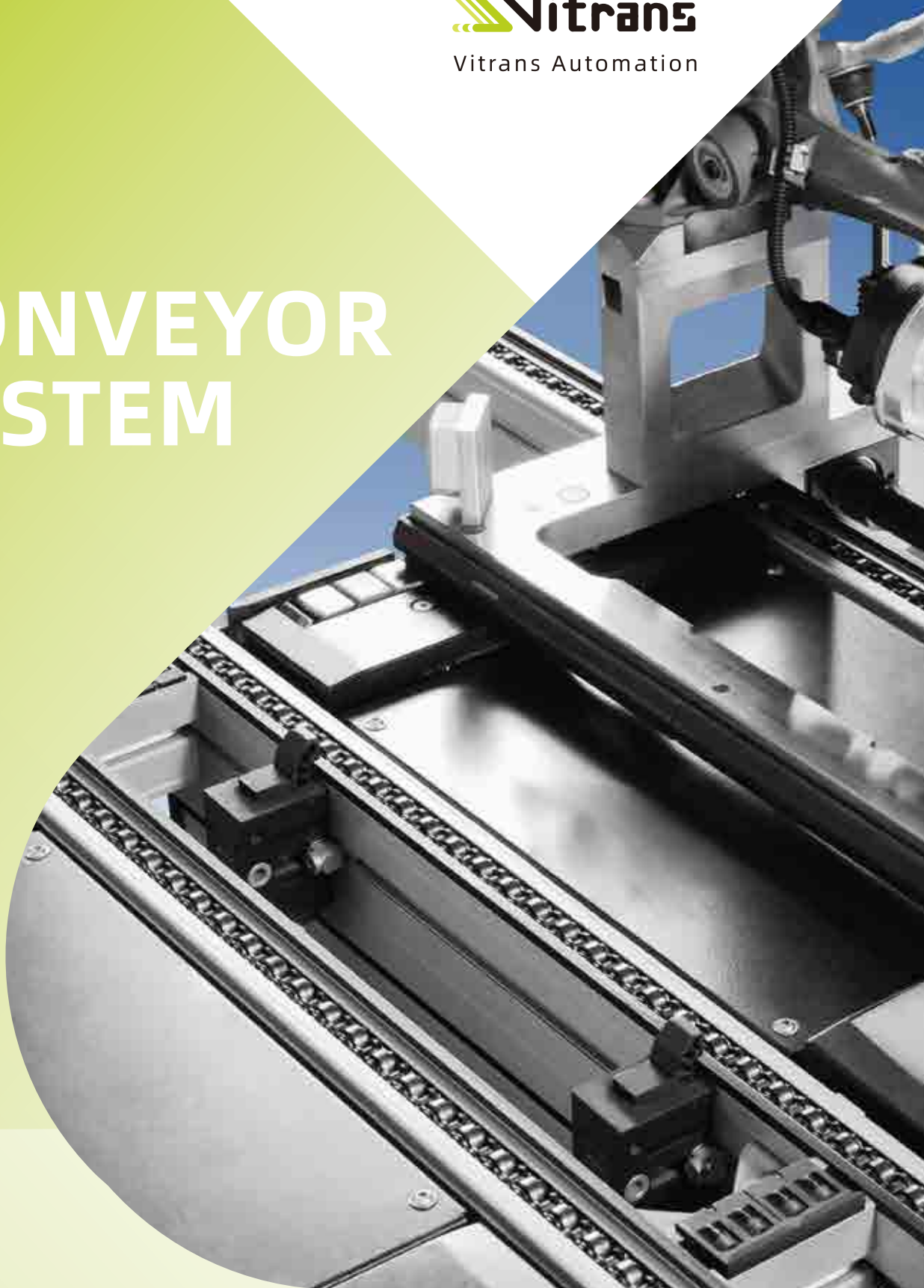



01

Product catalogue

-
- 01** Product catalogue P1
Product summary P2-7
-
- 02** Conveyor pallets P8-14
-
- 03** Longitudinal conveyors P15-40
-
- 04** Positioning units P41-50
-
- 05** Transverse conveyor P51-57
-
- 06** Rotate units P58-62
-
- 07** Curves P63-81
-
- 08** Lifter P82-92
-
- 09** Transportation control P93-115
-
- 10** Support unit P93-99
-
- 11** About System Specifications
P124-126

Pallet conveyor systems

The pallet conveyor system is designed to move workpiece pallets and is a versatile conveyor system that ensures economical production.

The system consists of a wide range of standardized conveyor bodies that can be equipped with modular mechanisms to meet a variety of automated production requirements.

Standard Conveyor Unit

Pallet conveyor systems include a wide range of standardized conveyor lines and workpiece pallets, according to different sites, production conditions and production requirement, we can quickly select the appropriate and meet the production requirements of the conveyor line for the production line layout:

- There are four types of conveyor media(PA belts,toothed belts,top chains and accumulation roller chains)
- Workpiece pallet sizes are customized according to product specifications.

Special type modular mechanism

In addition to the different types of conveyor line bodies, conveyor systems include a large number of modular mechanisms:

- Multiple curves
- Lift transverse
- Lift positioning
- Various lifts
- The use of various predefined function modules for the various corresponding supporting mechanisms and electrical supporting mechanisms saves a lot of time and effort in planning and design.



Working Principle

Pallets are loaded with parts to be machined and then passed by friction through a belt in constant motion, toothed belt, top chains, accumulation roller chains or round belt from one station to another by friction. When the manual or automatic station is reached, the stopper stops the workpiece pallets. When the manual or automatic station is reached, the stopper stops the workpiece pallet and the processing machine processes the workpieces on the pallet while the conveying medium can continue to run. The conveyor media can continue to run, and after the relevant process at the station is finished, the pallet is released and transferred to the next station. At the end of the relevant process at the station, the pallet is released and transferred to the next station until all processing is completed. After all the processes are completed, the processed workpieces are removed from the pallets and the pallets are returned to the next station to be loaded with the workpieces to be processed. The pallet is then returned to load the workpiece to be processed and the cycle continues.

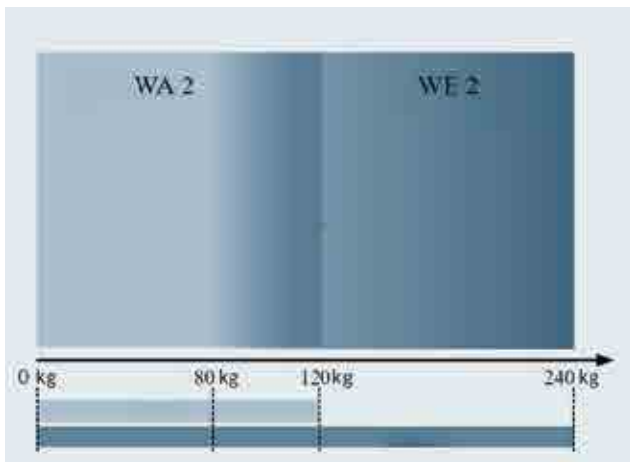
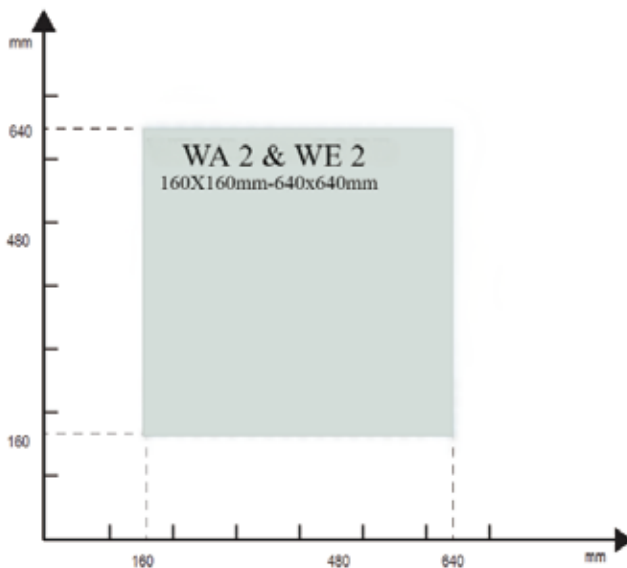

1-Products conveyed

Workpiece pallets

Pallets are used in conveyor systems as a means of transporting workpieces to different processing stations.

Workpiece pallets can be individually configured for various workpieces using individual components. For this purpose, different frame modules and carrier plates are available.

Permissible weight

In order not to exceed the maximum permissible surface pressure, the total weight of each workpiece pallets limited.

Total weight:

- Workpiece pallet weight
- Workpiece pallet loading (workpieces, fixtures, etc.)
- Weight of special equipment on pallets (storage, etc.)

Position of the stop

When using conveyor pallet, the stopper is installed at the left front and right rear of the pallet conveyor direction to stop the pallet.

2-Production Line Layout Plan

When planning the layout of a system, it is necessary to consider different sites, different product styles will bring different processing beats, different workstation operations to adopt different layouts, in order to shorten the cycle time and reduce operational waste.

Horizontal Loop Layout A

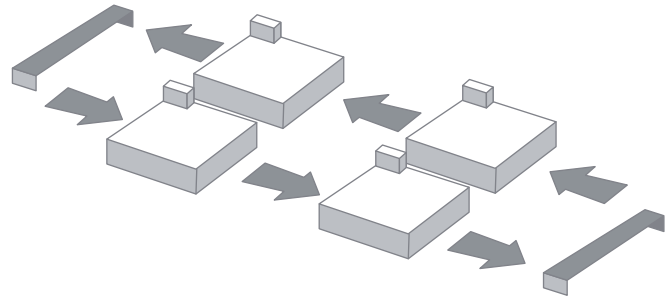

Horizontal Loop Layout B

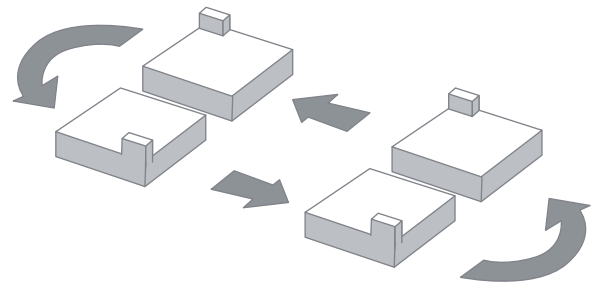

Vertical Loop Layout

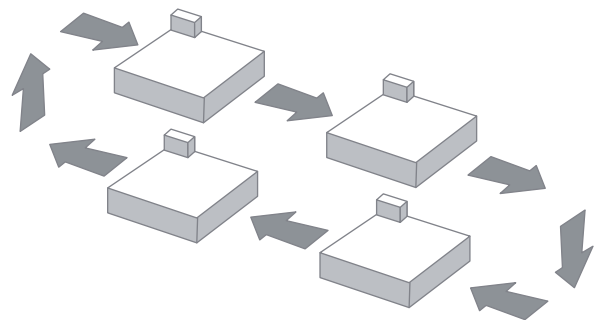

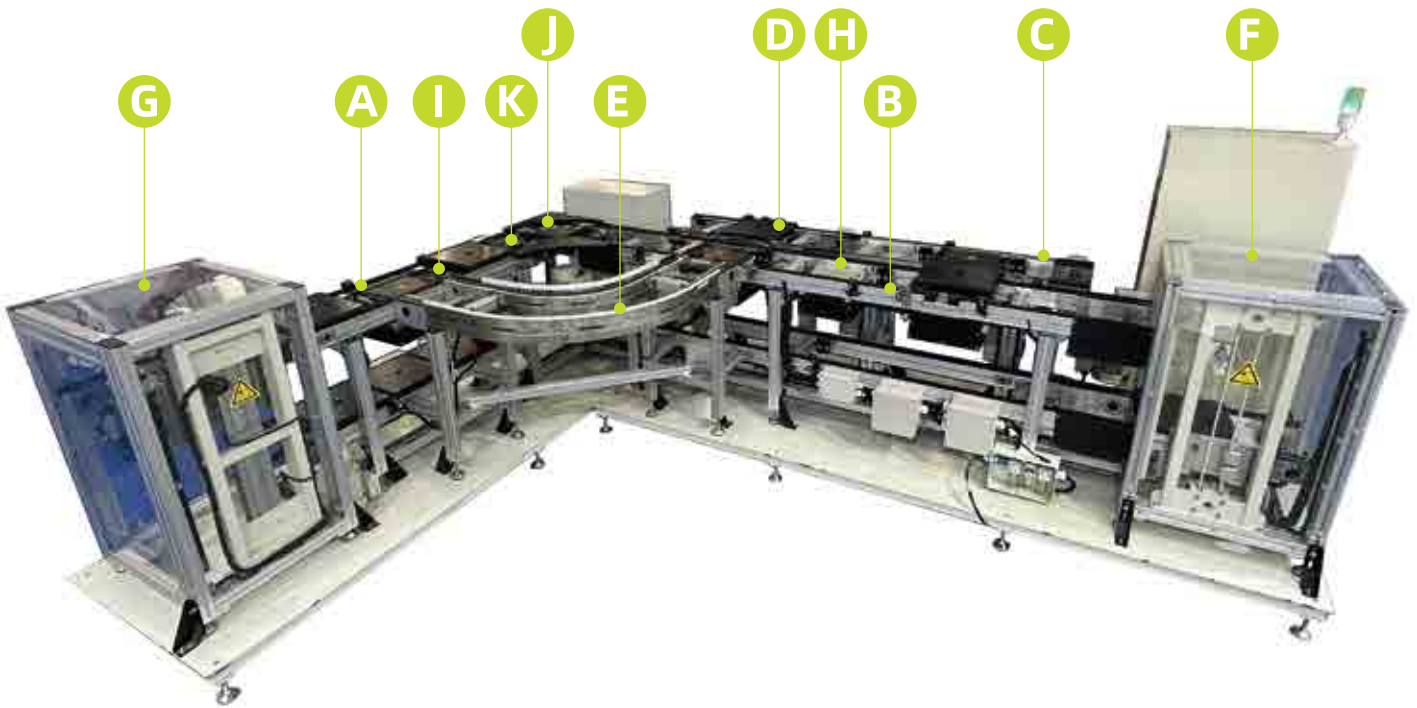

A Toothed Belt Conveyor (BC2)



B Flat Conveyor (FC2)



C Roller Chain Conveyor (AC2)



D Plastic Roller Chain Conveyor (PC2)

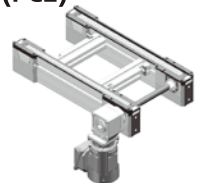

E Flat top Chain Curve Unit



F Servo Lifer



G Cylinder Lifer



H Positioning Unit



I Lift Transverse Unit



J Round Belt Curve Unit



K Rotate Unit



Each conveyor line is suitable for full load weights of up to 60kg for BC2, up to 200kg for PC2, up to 250kg for FC2, and up to 2,200kg for AC2, and can be used with a variety of modular mechanisms to achieve automated conveying under a wide range of conditions.

3-Conveying medium

The load capacity of the workpiece pallet depends on the following conditions:

- Conveying medium(Belt,Toothed Belt,Roller Chain,Top Chain)
- Length of surface contact between pallet and conveying medium Lwt or Bwt

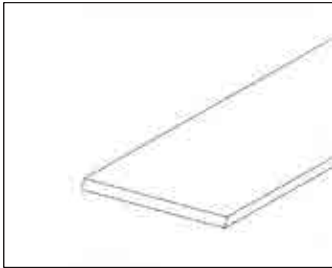

1. Belt

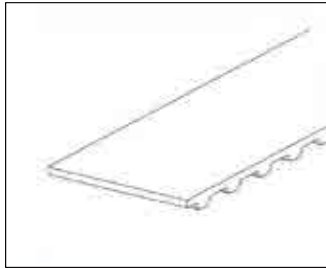

2. Toothed Belt

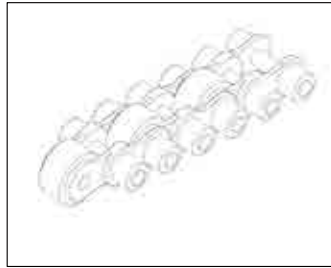

3. Roller Chain

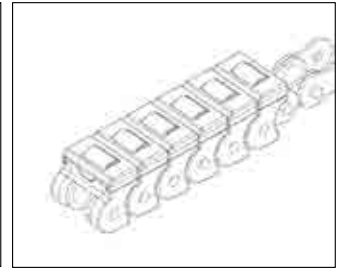

4. Flat top Chain

Conveying medium unit load capacity			Maximum permissible line load
Conveying medium	Unit load capacity (kg/cm)	Applicable pallets	Care must be taken in the design of single-section conveyor lines to ensure that the sum of the total weights of all the workpiece pallets accumulating at the same time in the section is less than the maximum permissible load of the section. If the maximum permissible section load is exceeded here, the section must be divided into several individual sections.
Belt	1 kg/cm	WA2	
Toothed Belt	1 kg/cm	WA2	
Roller Chain	1.5 kg/cm(plastic wear strips)	WE2	
	2 kg/cm(steel wear strips)	WE2	
Top Chain	0.5 kg/cm	WE2	

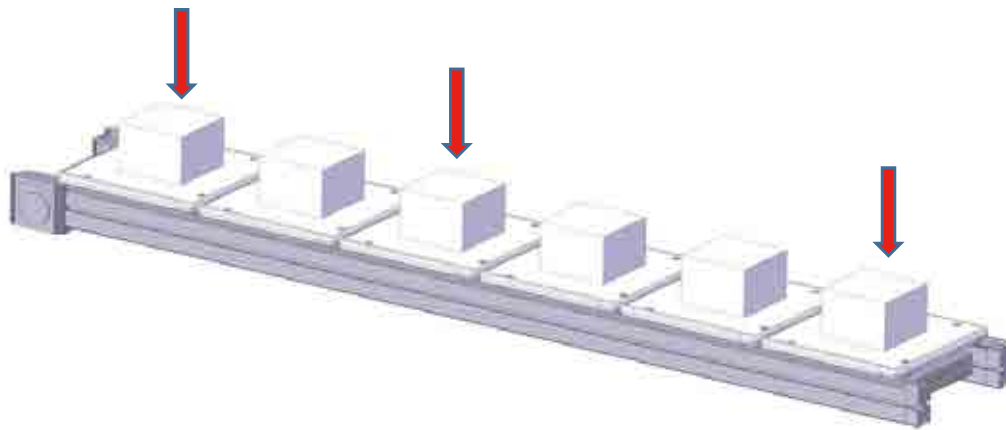

4-Environmental conditions



Climactic

Conveyor systems designed for fixing in climate-proof areas.

operating temperature

+5 to +40°C

Above +40 °C or below +5 °C, the load capacity will be affected;

Storage temperature

0°C to +35°C.

relative humidity

5% to 85% without condensation 1-2% (dry room), on request.

ecological environment

Protection against mould, fungi, rodents and other pests.

chemical environment

Do not install next to an industrial system with chemical emissions.

physical environment

Do not locate close to places with a lot of chips, sand and dust. Do not install in places that are often subjected to large impacts, such as punch presses and heavy machinery.

02

Conveyor pallets

Conveyor system in which the pallet serves as a medium for transporting the workpieces to the various stations with its own positioning bushings for positioning the workpieces to be transported to the machining stations.

WA2—Conveyor pallets

WE2—Conveyor pallets

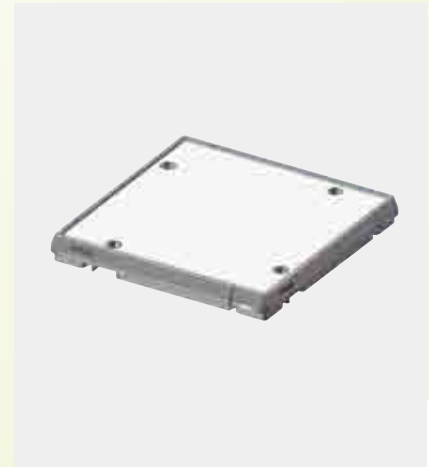
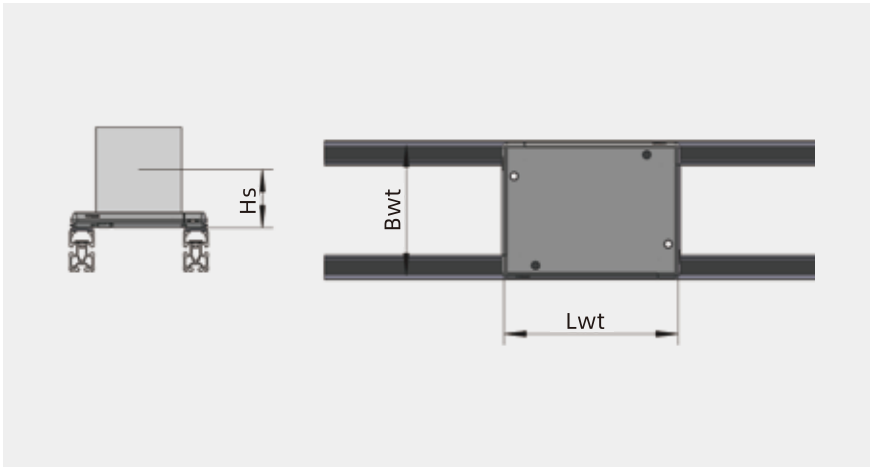

Types of pallets:

WA2-Pallet with PA wear pad,suitable for FC 2/BC 2/LC 2 conveyor medium;

WE2-Pallet with PE wear pad,suitable for AC 2 conveyor medium.

Advantage:

Corner modules for sides with lengths of 160,240,320 and 400mm;Frame extension modules with a length of 320mm;Using different combinations to build target size of workpiece pallet;

Stop gates can be mounted inside or outside the workpiece pallet;Accumulation operation possible;

Integrated positioning bushings for accuracy positioning and Guide groove for rough positioning;

Exciter plates on both bottom and sides,which can adapt to the proximity switch in multiple directions;

Installation space for RFID data carriers.

Selection:

Select workpiece pallet type(WA2 or WE2)base on workpiece and fixture weights;

Select workpiece pallet size base on workpeice and fixture size.



Selection instructions:

Select workpiece pallet type base on conveyor medium to ensure the workpiece pallet permitted load:

- For belts,toothed belts,and flat top chains,select WA2 to ensure surface load up to 1 kg/cm;

- For accumulation roller chains and top chains,select WA2 to ensure surface load up to 2 kg/cm;

Workpiece pallet permitted load is decided by the contact length between pallet and conveyor medium;workpiece pallet permitted load = contact length*1kg/cm;

When stopping the pallet or changing the conveying direction, the centre of gravity of the loaded workpieces on the pallet must be observed to ensure that the accelerating forces are absorbed without interference. In general, we recommend:

- Loads must be placed in the centre of the workpiece pallet, off-set loads will affect the service life of the conveyor line;

- The center of gravity should not exceed a height h_s of $1/2 Bwt$ (with $Bwt \leq Lwt$)to ensure that the acceleration forces canbe absorbed without any interferences;

The load should be positioned in the center of the workpiece pallet to ensure conveyor life;

For workpiece pallets that the permitted total weight may be different for longitudinal conveyors and transverse and the shorter side is the determining factor for the maximum load;

When designing the conveyor sections,it is important to ensure that the conveyor section in accumulation operation at one time,is less than the permitted load for the conveyor section.

WA2 Workpiece Pallet

The workpiece pallets is used in the transfer system to convey the workpiece through the processing stations.

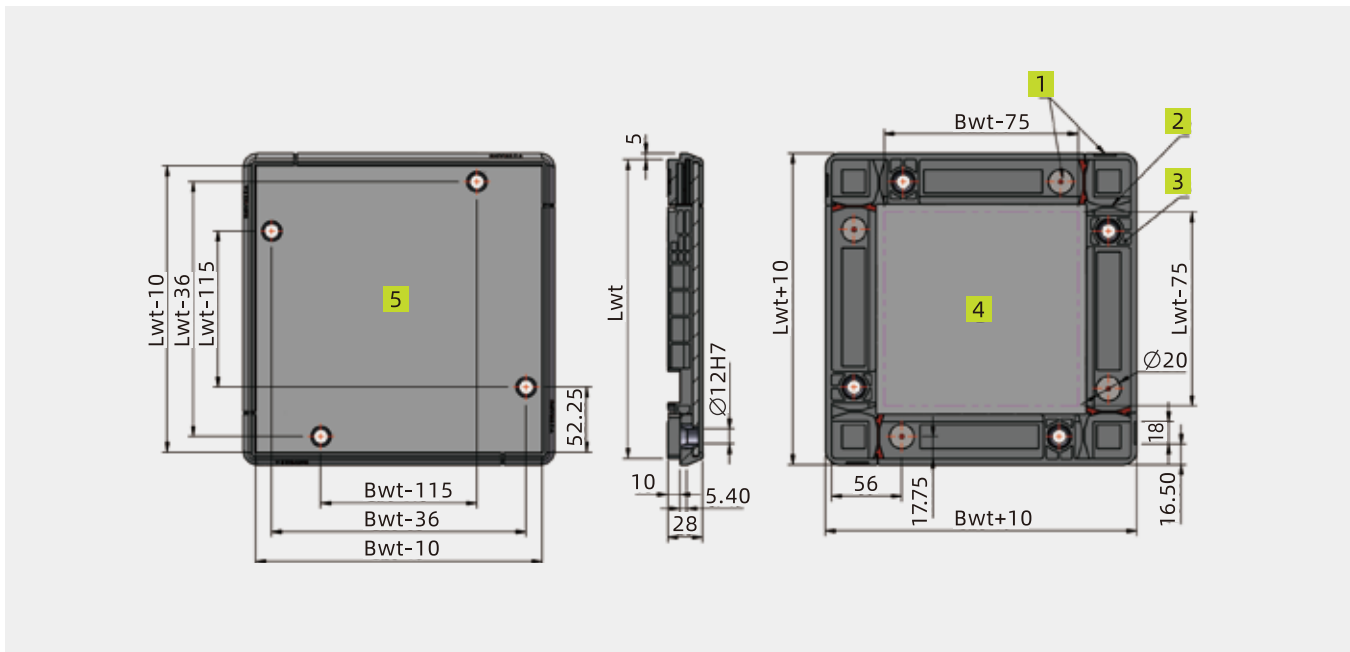

1. Exciter plate 2. Guide groove 3. Stop gate aperture 4. Bottom clearance 5. Top clearance

■
Used on conveyor medium:
 belts, toothed belts, and flat top chains;

Robust workpiece pallet with high rigidity

Repeat accuracy of integrated positioning bushings is up to $\pm 0.05\text{mm}$

Prepared for installation of mobile data tags

Plastic frame modules with PA wear pads and universal steel carrying plate

■
Aluminum carrying plate:
 5mm/8mm/12mm

42 standard sizes

Permitted load up to 120kg

Exciter plates on both bottom and sides; Suitable for use in ESD

■
Delivery notes

Scope of delivery: Carrying plate 1), Frame modules Fittings 2), Positioning bushings

Condition on delivery: Fully assembled/Part

1) Carrying plate can be customized. Provide fixture design and installation holes machining service;
 2) From size 400x400mm, the workpiece pallet plates are executed as standard with four additional threaded holes for reinforcing bolts.

WA2 Ordering comformation

Workpiece Pallet size		Carrying plate thickness	Flatness 	Carrying plate material	Carrying plate surface treatment	Carrying plate weight	Material number
Bwt	Lwt	(mm)	(mm)			(KG)	
160	160	5	0.3	Aluminium	Black	0.32	1098663410
160	240	5	0.3			0.48	1098663412
160	320	5	0.3			0.65	1098663415
240	240	5	0.3			0.74	1098663416
240	320	5	0.5			0.99	1098663418
240	400	5	0.5			1.24	1098663421
320	320	5	0.5			1.33	1098663424
320	400	5	0.5			1.67	1098663427
400	400	5	0.6			2.10	1098663434
240	320	8	0.5			1.55	1098663420
240	400	8	0.5			1.95	1098663423
320	320	8	0.5			2.06	1098663426
320	400	8	0.5			2.63	1098663429
320	480	8	0.5			3.16	1098663432
400	400	8	0.6			3.31	1098663436
400	480	8	0.6			3.96	1098663440
400	640	8	0.8			5.33	1098663443
480	480	8	0.8			4.79	1098663447
480	640	8	0.8			6.42	1098663450
480	800	8	1			8.05	1098663452
640	640	8	0.8			8.61	1098663455
640	800	8	1			10.79	1098663457
800	800	8	1			13.53	1098663459
320	480	12	0.5			4.71	1098663433
400	400	12	0.5			4.92	1098663437
400	480	12	0.6			5.93	1098663441
400	640	12	0.8			7.95	1098663444
480	480	12	0.6			7.14	1098663448
480	640	12	0.8			9.58	1098663451
480	800	12	0.8			12.01	1098663453
640	640	12	1			12.85	1098663456
640	800	12	1			16.12	1098663458
800	800	12	1	20.22	1098663460		

WE2 Workpiece Pallet

The workpiece pallet is used in the transfer system to convey the workpiece through the processing stations.

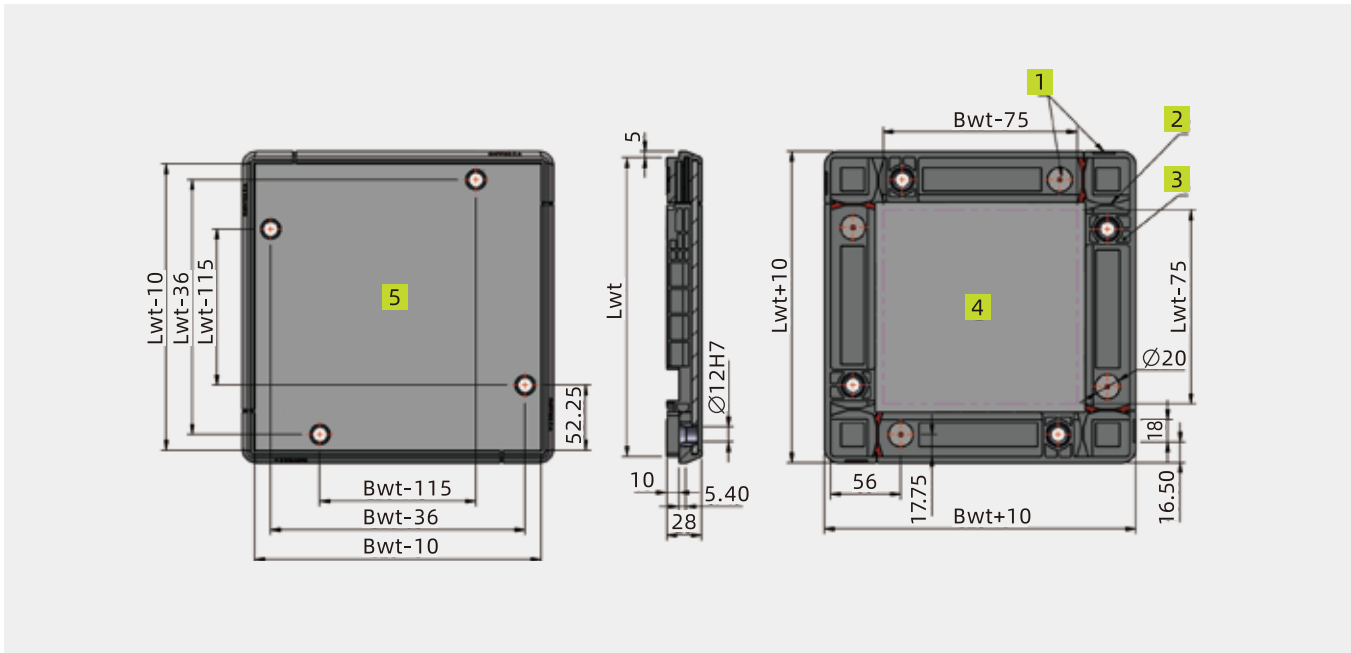

- 1. Exciter plate
- 2. Guide groove
- 3. Stop gate aperture
- 4. Bottom clearance
- 5. Top clearance

Used on conveyor medium: accumulation roller chains Robust workpiece pallet with high rigidity

Repeat accuracy of integrated positioning bushings is up to $\pm 0.05\text{mm}$

Prepared for installation of mobile data tags

Plastic frame modules with PA wear pads and universal steel carrying plate

Aluminum carrying plate:
4.8mm/8mm/12mm

42 standard sizes

Permitted load up to 240kg

Exciter plates on both bottom and sides; Suitable for use in ESD

Delivery notes

Scope of delivery: Carrying plate 1), Frame modules Fittings 2), Positioning bushings

Condition on delivery: Fully assembled/Part

1) Carrying plate can be customized. Provide fixture design and installation holes machining service;

2) From size 400x400mm, the workpiece pallet plates are executed as standard with four additional threaded holes for reinforcing bolts.

WE2 Ordering comformation

Workpiece Pallet size		Carrying plate thickness	Flatness 	Carrying plate material	Carrying plate surface treatment	Carrying plate weight	Material number
Bwt	Lwt	(mm)	(mm)			(KG)	
160	160	5	0.3	Aluminium	Black	0.32	1098663410
160	240	5	0.3			0.48	1098663412
160	320	5	0.3			0.65	1098663415
240	240	5	0.3			0.74	1098663416
240	320	5	0.5			0.99	1098663418
240	400	5	0.5			1.24	1098663421
320	320	5	0.5			1.33	1098663424
320	400	5	0.5			1.67	1098663427
400	400	5	0.6			2.10	1098663434
240	320	8	0.5			1.55	1098663420
240	400	8	0.5			1.95	1098663423
320	320	8	0.5			2.06	1098663426
320	400	8	0.5			2.63	1098663429
320	480	8	0.5			3.16	1098663432
400	400	8	0.6			3.31	1098663436
400	480	8	0.6			3.96	1098663440
400	640	8	0.8			5.33	1098663443
480	480	8	0.8			4.79	1098663447
480	640	8	0.8			6.42	1098663450
480	800	8	1			8.05	1098663452
640	640	8	0.8			8.61	1098663455
640	800	8	1			10.79	1098663457
800	800	8	1			13.53	1098663459
320	480	12	0.5			4.71	1098663433
400	400	12	0.5			4.92	1098663437
400	480	12	0.6			5.93	1098663441
400	640	12	0.8			7.95	1098663444
480	480	12	0.6			7.14	1098663448
480	640	12	0.8			9.58	1098663451
480	800	12	0.8			12.01	1098663453
640	640	12	1			12.85	1098663456
640	800	12	1			16.12	1098663458
800	800	12	1	20.22	1098663460		

Customized model description

WA2	Workpiece pallet type: WA2 WE2
B <input type="checkbox"/>	Pallet width: B160 / B240 / B320 / B400 / B480 / B640 / B800 / Customized
L <input type="checkbox"/>	Pallet length: L160 / L240 / L320 / L400 / L480 / L640 / L800 / Customized
T <input type="checkbox"/>	Carrying plate thickness: T5 / T8 / T12
A1	Carrying plate material: A1(Aluminium alloy)
SP	Special requirement: a.Special press force requirement b.Special pointioning requirement c.Special surface treatment d.For special plate material requirement, please contact us.

Customized model example

WA2-B320-L320-T8-A1

Workpiece pallet type: WA2 **Pallet length:** Bwt=320 **Pallet width:** Lwt=320 **Carrying plate thickness:**8mm

Carrying plate material:A1(Aluminium alloy) **Special requirement:** None

03

Longitudinal conveyors

Longitudinal conveyors is ready for operation with own drive for the transportation of workpiece pallets.

BC2——Conveyor

BC2/M——Conveyor

FC2——Conveyor

AC2——Conveyor

AC2/H——Conveyor

PC2——Conveyor

Conveyor medium type, Technical data:

·BC2 Conveyor

·BC2/M Conveyor

Toothed belt conveyor section,permitted accumulation operation load 60kg,permitted surface load 1kg/cm;

·FC2 Conveyor

Flat top chains conveyor section,permitted accumulation operation load 250kg,permitted surface load 1kg/cm;

·AC2 Conveyor

·AC2/H Conveyor

Accumulation roller chains conveyor section,permitted accumulation operation load 2200kg,permitted surface load 1.5kg/cm(Plastic Wear Resistant strips), 2kg/cm(steel wear strips)

·PC 2 Conveyor

Top chains section,permitted accumulation operation load 200kg,permitted surface load 0.5kg/cm

Advantages:

Standard modular system offers numerous modules,all of which enable you to implement,modify or maintain a transfer system tailored precisely to the particular application;

Optional conveyor medium include toothed belt,belt,accumulation roller chains and top chain,workpiece pallet permitted load is up to 240kg;

Allow accumulation operation,and achieve different types of layouts with curves,lifts-,transvers,etc;

Widely used in EV,auto parts,3C,motors and other industries.

Selection instruction:

1.Toothed belt mainly use for:short distance transportation below 6 meters,allow forward and reverse operation,suitable for clean,dry and low load environment;

2.Flat belt mainly use for:long distance transportation above 2 meters,allow only forward operation,suitable for clean,dry and low load environment;

3.Top chain mainly use for:short distance transportation below 8 meters, with plastic overhead attachment, suitable for light load and high cleanliness requirement environment;

4.Accumulation chain mainly use for:allow

forward and reverse operation below 2 meters,allow only forward operation above 2 meters,suitable for harsh environment;

5.Ensure that the total weight of the workpiece is less than the maximum allowable load of the conveyor,and that the weight per unit length of the pallet is less than the maximum allowable load;

6.Mixed use of 4 kinds of conveyor medium can make a cost-effective proposal.

BC2 Belt Section

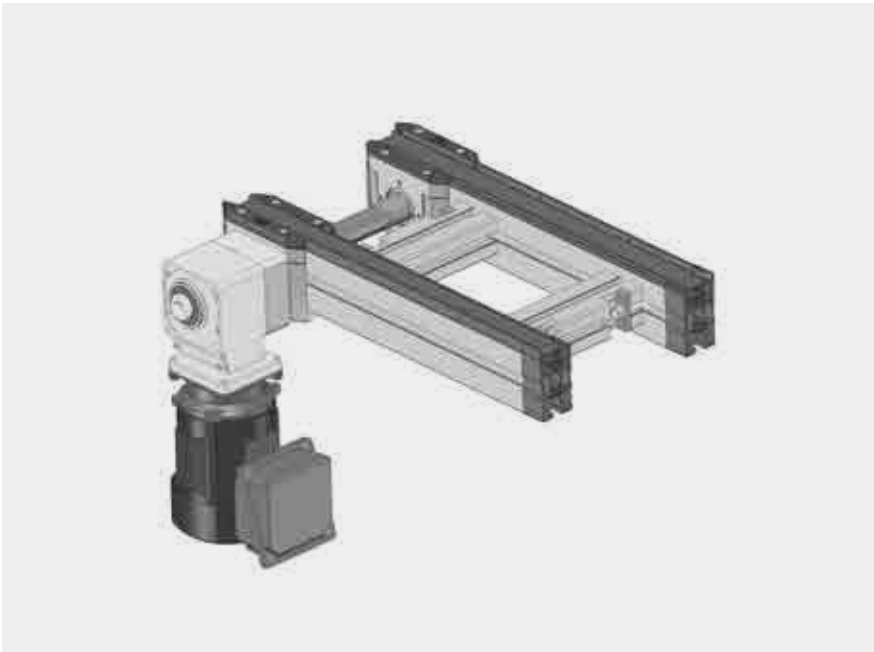

Delivery note

Recommended accessories

Connection kits
Legs
Anchor bolts

Condition on delivery

Complete supply

- ▶ Conveyor medium:toothed belt
 - ▶ Driven by 3-phase motors **1**,with multiple installation methods,and several installation angles,see the schematic diagram for details
 - ▶ No more than 6 meters
 - ▶ Allow accumulation operation
 - ▶ Modular sets
 - ▶ Allow forward and reverse operation
 - ▶ ESD-compatible
 - ▶ Special model on request
- 1** Other types of motors are optional,please contact us for detail.

Dimensions

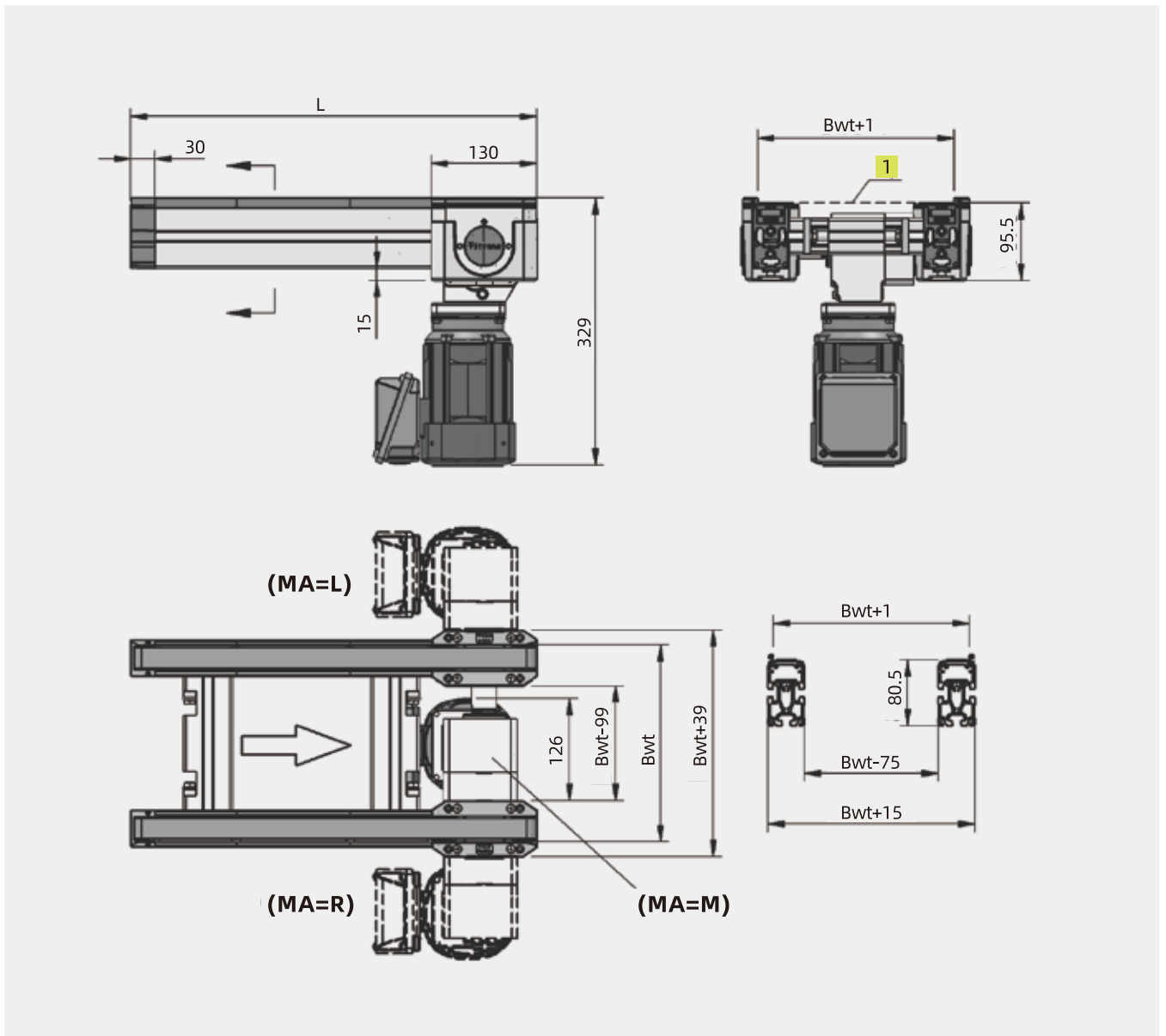

1. Surface of conveying medium

Ordering informationt

Conveyor medium		Toothed belt
Width(mm)*	Bwt	160,240,320,400,480,640,800 $160 \leq Bwt \leq 1200$
Length(mm)*	L	$300 \leq L \leq 6000$
Nominal speed(m/min)*	V	0,6,9,12,15,18
Max. Load(kg)		60
Drive method		Motor drive
Motor mounting way*	MA	L,M,R
Motor mounting direction		$0^\circ, 90^\circ, 180^\circ, 270^\circ$
Voltage*	U	220/380AC
Frequency*	f	50Hz
Motor connection*	AT	Terminal box

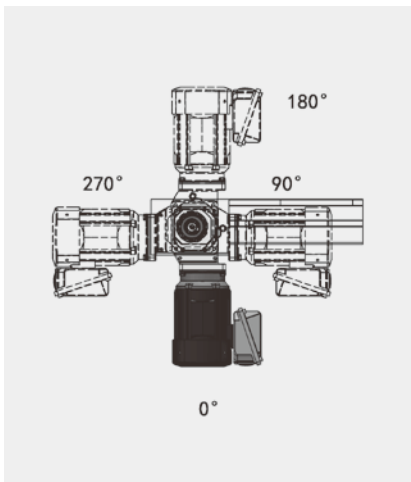

Width	Width can be customized;
Nominal speed	When $V=0$, no motor is configure,
Motor mounting way	and other speeds can be customized;
Voltage	MA=M, only applicable to occasions with $Bwt \geq 240$;
Frequency	For other power supply voltage requirements, Please contact us for details;
Motor connection	a. For other power frequency requirements, please inquire; b. Can be adjusted by frequency converter; The Terminal box and outlet are shown in the figure, Please call for other requirements.

BC2/M belt section

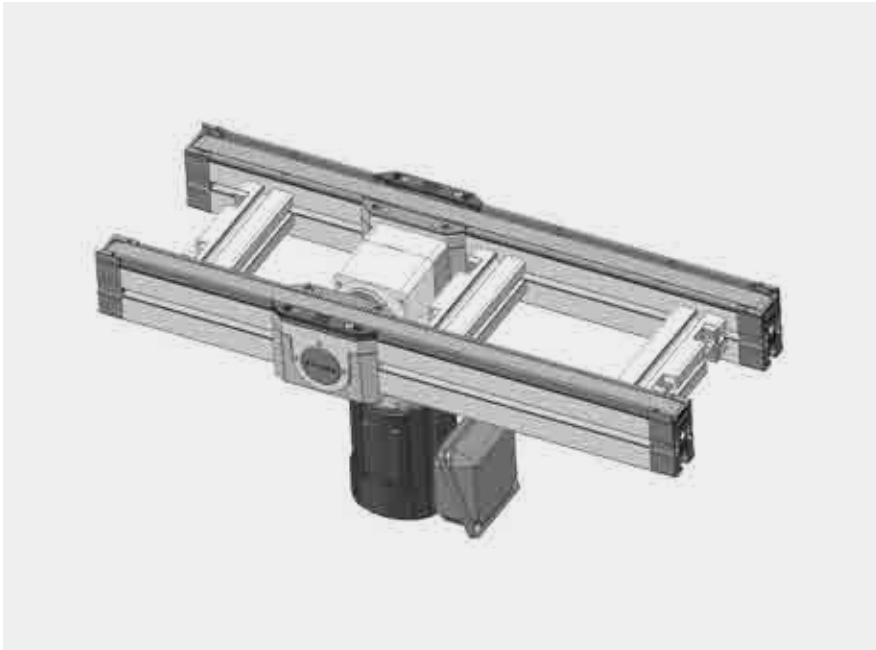

Delivery note

Recommended accessories

Connection kits

Legs

Anchor bolts

Condition on delivery

Complete supply

- ▶ Conveyor medium:toothed belt
- ▶ Driven by 3-phase motors **1**,with multiple installation methods,and several installation angles,see the schematic diagram for details
- ▶ Allow accumulation operation
- ▶ Modular sets
- ▶ Allow forward and reverse operation
- ▶ ESD-compatible
- ▶ Special model on request

1 Other types of motors are optional,please contact us for detail.

Dimensions

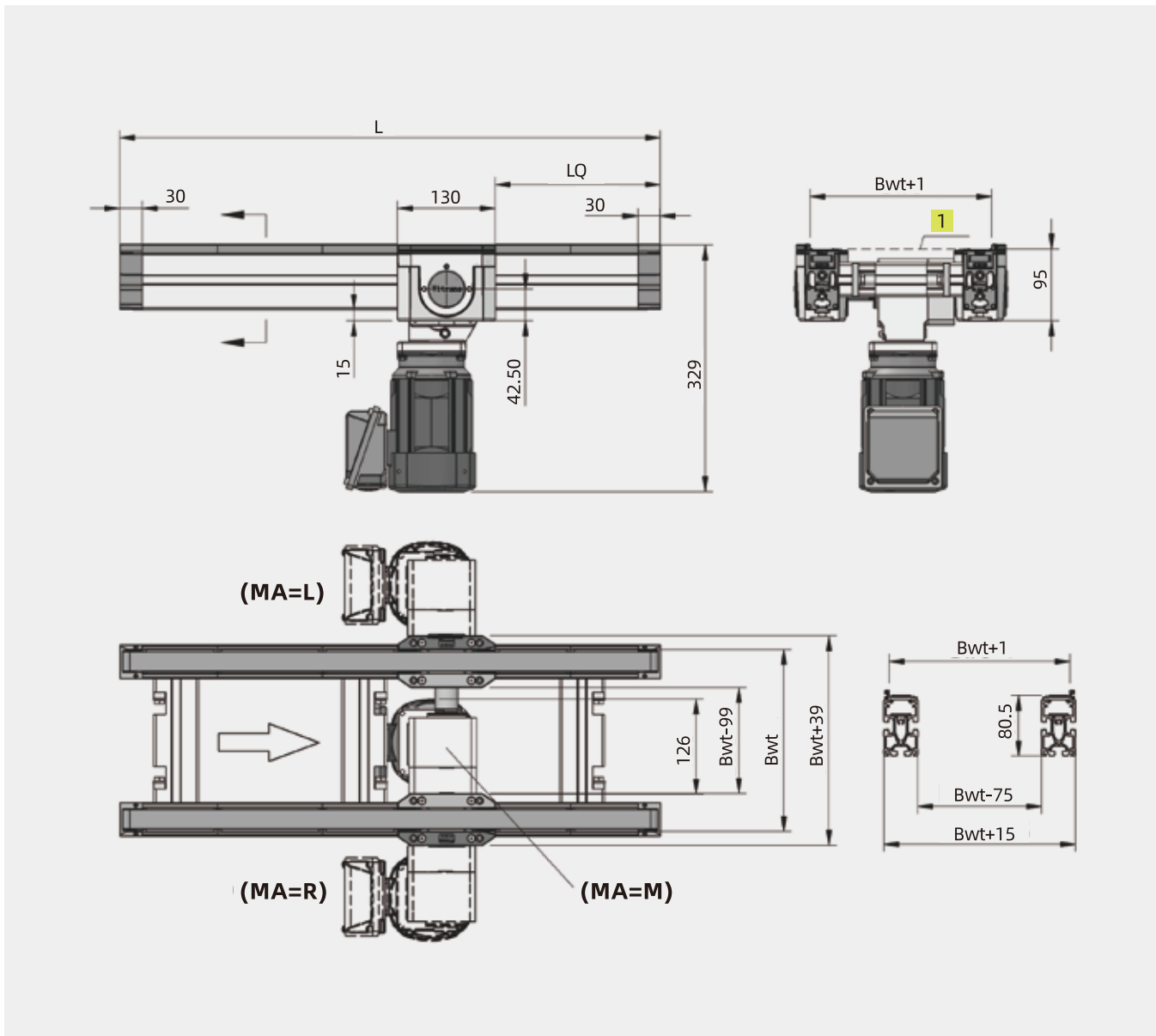

1. Surface of conveying medium

Ordering information

Conveyor medium		Toothed belt
Pallet width(mm)*	Bwt	160,240,320,400,480,640,800, 160≤Bwt≤1200
Conveyor length(mm)*	L	300≤L≤6000
Extended length(mm)	LQ	100≤L≤5700
Nominal speed(m/min)*	V	0,6,9,12,15,18
Max. Load(kg)		60
Drive method		Motor drive
Motor mounting way*	MA	L,M,R
Motor mounting direction		0°, 90°, 180°, 270°
Voltage*	U	220/380AC
Frequency*	f	50Hz
Motor connection*	AT	Terminal box

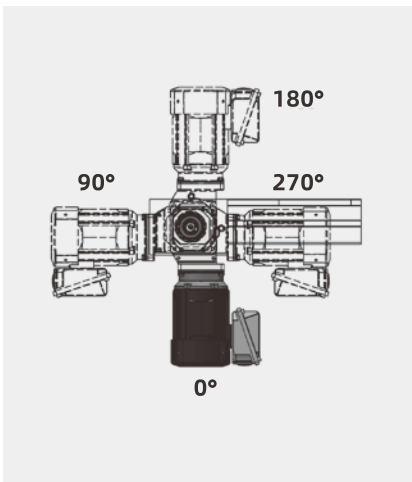

▲ Schematic diagram of motor mounting

Width	Width can be customized;
Nominal speed	When V=0,no motor is configure,
Motor mounting way	and other speeds can be customized;
Voltage	MA=M,only applicable to occasions with Bwt≥240;
Frequency	For other power supply voltage requirements, Please contact us for details;
Motor connection	a.For other power frequency requirements,please inquire; b.Can be adjusted by frequency converter; The Terminal box and outlet are shown in the figure, Please call for other requirements.

Customized model description

BC2	Conveyor type: BC2 BC2/M
B <input type="checkbox"/>	Pallet width: B160 / B240 / B320 / B400 / B480 / B640 / B800 / Customized
L <input type="checkbox"/>	Length: $300 \leq L \leq 6000$
LQ <input type="checkbox"/>	Extended length: BC2Length:0
V <input type="checkbox"/>	Nominal speed: 01) / 6 / 9 / 12 / 15 / 18 / Customized
MA	Motor mounting way: L R M
A <input type="checkbox"/>	Motor mounting direction: 0 / 90 / 180 / 270
SP	Special requirement: a.a.Special voltage requirement b.Special Frequency requirement c.Special Terminal box and outlet requirement d.Special motor connection requirement e.Special motor mounting requirement 1) When speed is 0 , means no drive motor

Customized model example

BC2—B320—L2000—LQ1000—V12—L—A0

Conveyor type:BC2 **Length:** Bwt=320 **Width:** L=2000 **Extended length::**LQ=1000 **Nominal speed:**12m/min

Motor mounting way: MA=L **Motor mounting direction:** 0° **Special requirement:**None

FC2 belt section

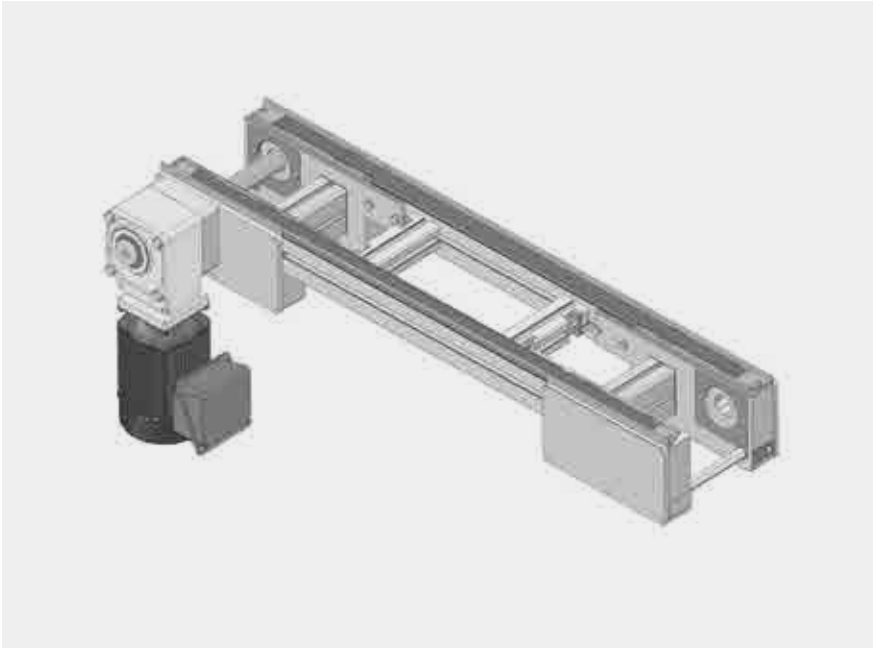

Delivery note

Recommended accessories

Connection kits

Legs

Anchor bolts

Condition on delivery

Complete supply

- ▶ Conveyor medium: flat belt
Driven by 3-phase motors **1**, with multiple installation methods, and several installation angles, see the schematic diagram for details
- ▶ Allow accumulation operation
- ▶ Modular sets
- ▶ Allow forward and reverse operation
- ▶ ESD-compatible
- ▶ Special model on request

1 Other types of motors are optional, please contact us for detail.

Dimensions

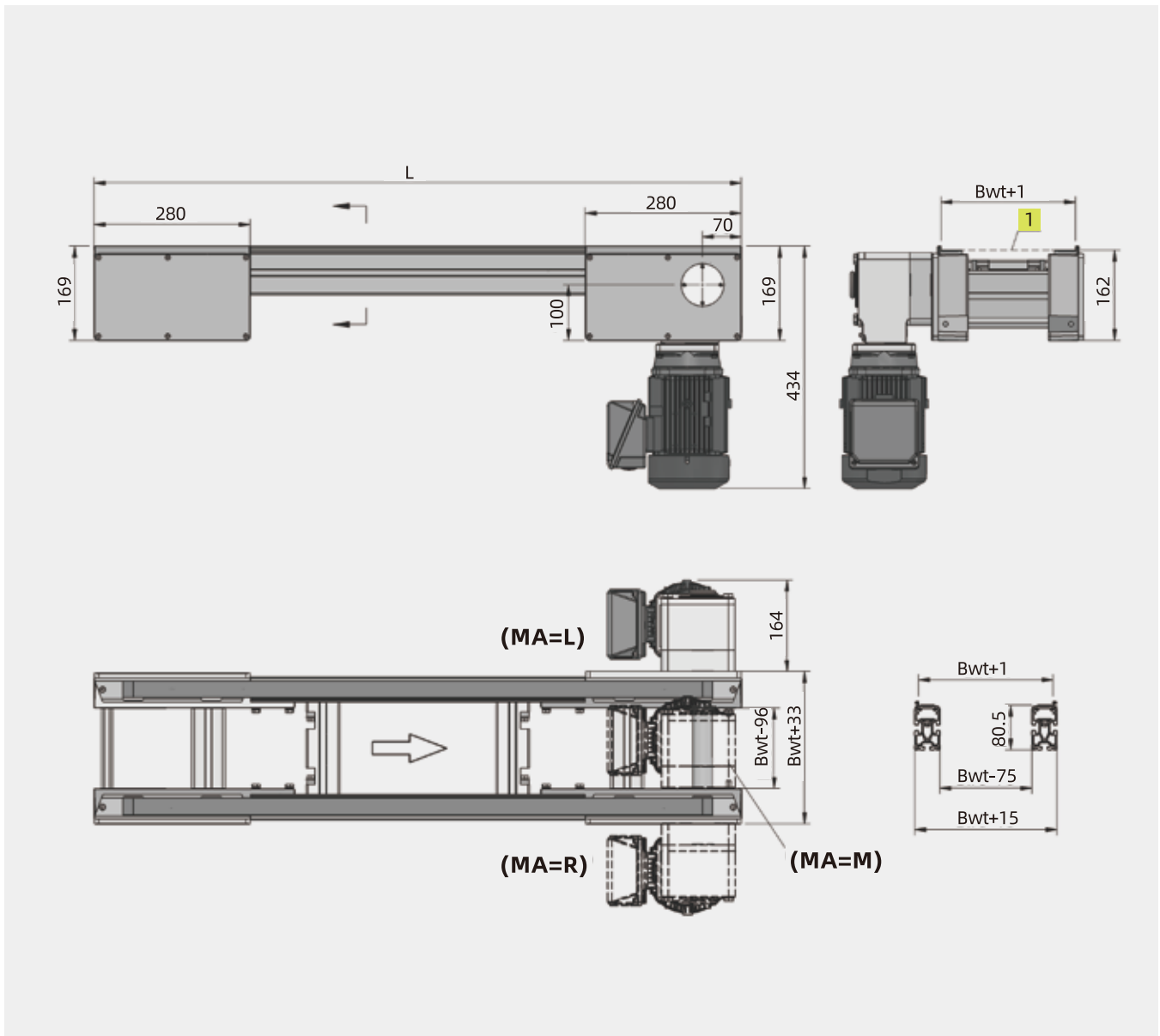

1. Surface of conveying medium

Ordering information

Conveyor medium		Flat belt
Pallet width(mm)*	Bwt	160,240,320,400,480,640,800,160≤Bwt≤1200
Conveyor length(mm)*	L	1000 < L ≤ 25000
Nominal speed(m/min)*	V	0,6,9,12,15,18
Max. Load(kg)		250
Drive method		Motor drive
Motor mounting way*	MA	L,R,M
Motor mounting direction		0°, 90°, 180°, 270°
Voltage*	U	220/380AC
Frequency*	f	50Hz
Motor connection*	AT	Terminal box

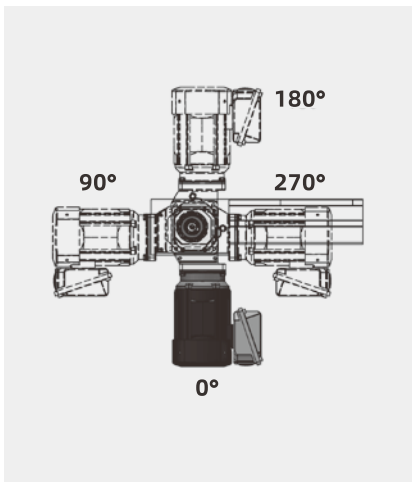

▲ Schematic diagram of motor mounting

Width	Width can be customized;
Nominal speed	When V=0,no motor is configure, and other speeds can be customized;
Max. Load(kg)	Max. Load can be customized;
Voltage	For other power supply voltage requirements, Please contact us for details;
Frequency	a.For other power frequency requirements,please inquire; b.Can be adjusted by frequency converter;
Motor connection	The Terminal box and outlet are shown in the figure, Please call for other requirements.

Customized model description

FC2	Conveyor type: FC2
B <input type="checkbox"/>	Width: B160 / B240 / B320 / B400 / B480 / B640 / B800 / Customized
L <input type="checkbox"/>	Length: 1000 < L ≤ 25000
V <input type="checkbox"/>	Nominal speed: 01) / 6 / 9 / 12 / 15 / 18 / Customized
MA	Motor mounting way: L R M
A <input type="checkbox"/>	Motor mounting direction: 0 / 90 / 180 / 270
SP	Special requirement: <ul style="list-style-type: none"> a.Special voltage requirement b.Special Frequency requirement c.Special Terminal box and outlet requirement d.Special motor connection requirement e.Special motor mounting requirement <p style="color: green;">1) When speed is 0 , means no drive motor</p>

Customized model example

FC2 — B320 — L3000 — V12 — L — A0

Conveyor type:FC2 **Length:** Bwt=320 **Width:** L=3000 **Nominal speed:**12m/min **Motor mounting way:**MA=L

Motor mounting direction:0° **Special requirement:** 无

AC2 Accumulation roller chain section

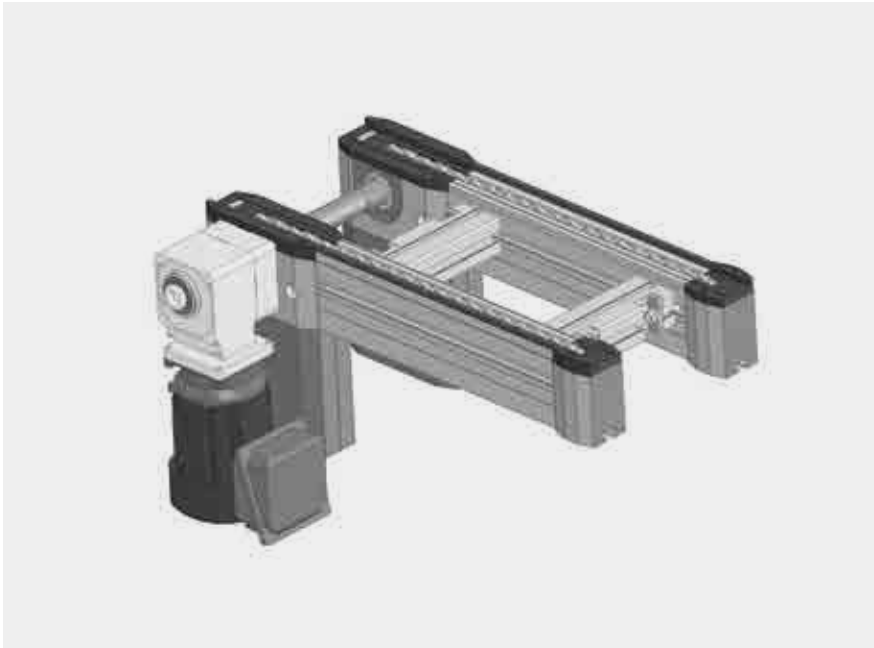

Delivery note

Recommended accessories

Connection kits
 Legs
 Anchor bolts
 Automatic lubrication

Condition on delivery

Complete supply

- ▶ Conveyor medium: accumulation chain
- ▶ Driven by 3-phase motors ¹, with multiple installation methods, and three installation angles, see the schematic diagram for details
- ▶ Optional small parts protection (to prevent small parts from entering the profile guiding)
- ▶ Length $l \leq 1800$ mm, can be forward and reverse operation without small parts protection
- ▶ Allow accumulation operation
- ▶ Modular sets
- ▶ ESD-compatible
- ▶ Special model on request

¹ Other types of motors are optional, please contact us for detail.

Dimensions

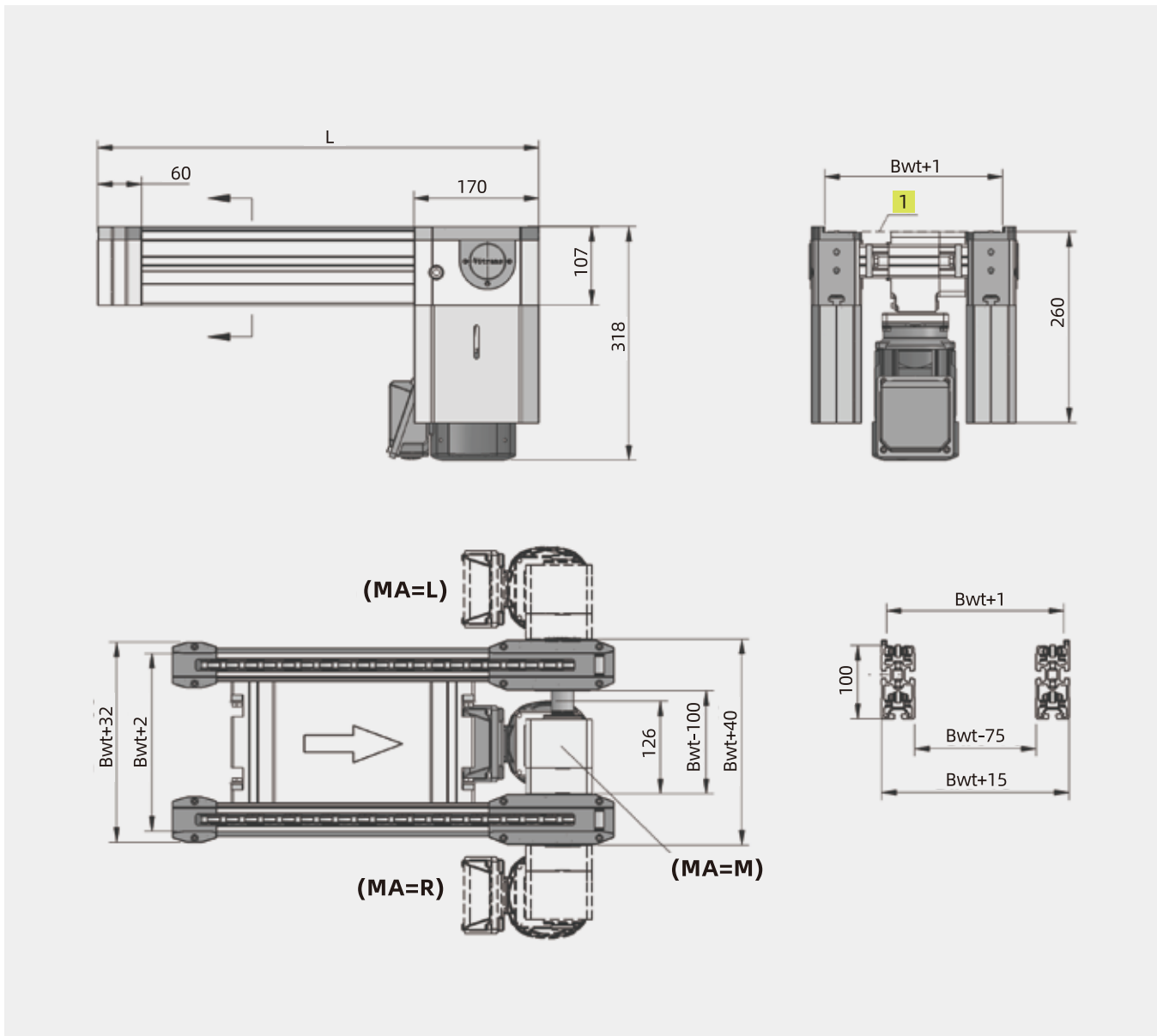

1. Surface of conveying medium

Ordering information

Conveyor medium		Accumulation roller chain with PA rollers Accumulation roller chain with steel rollers Accumulation roller chain with PA rollers and small parts protection Accumulation roller chain with steel rollers and small parts protection
Width(mm)*	Bwt	160,240,320,400,480,640,800, 160≤Bwt≤1200
Length(mm)*	L	300 < L≤6000(When reverse operation≤2000)
Nominal speed(m/min)*	V	0,6,9,12,15,18
Max. Load(kg)		700
Drive method		Motor drive
Motor mounting way*	MA	L,R,M
Motor mounting direction		0°, 90°, 180°, 270°
Voltage*	U	220/380AC
Frequency*	f	50Hz
Motor connection*	AT	Terminal box

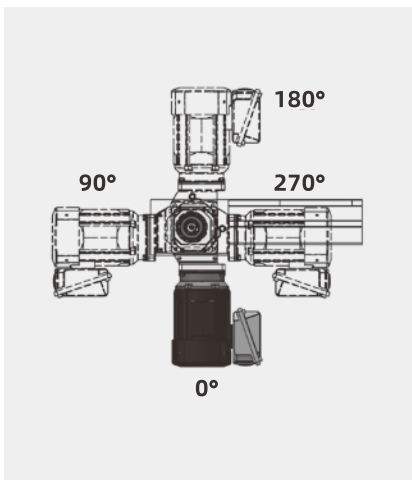

▲ Schematic diagram of motor mounting

Pallet width	Width can be customized;
Nominal speed	When V=0,no motor is configure, and other speeds can be customized;
Motor mounting way	MA=M,only applicable to occasions with Bwt≥240;
Voltage	For other power supply voltage requirements, Please contact us for details;
Frequency	a.For other power frequency requirements,please inquire; b.Can be adjusted by frequency converter;
Motor connection	The Terminal box and outlet are shown in the figure, Please call for other requirements.

AC2/H Accumulation roller chain section



Delivery note

Recommended accessories

Connection kits
Legs
Anchor bolts
Automatic lubrication

Condition on delivery

Complete supply

- ▶ Conveyor medium: accumulation chain
- ▶ Driven by 3-phase motors **1**, with multiple installation methods, and three installation angles, see the schematic diagram for details
- ▶ Optional small parts protection (to prevent small parts from entering the profile guiding)
- ▶ Allow accumulation operation
- ▶ Modular sets
- ▶ ESD-compatible
- ▶ Special model on request

1 Other types of motors are optional, please contact us for detail.

Dimensions

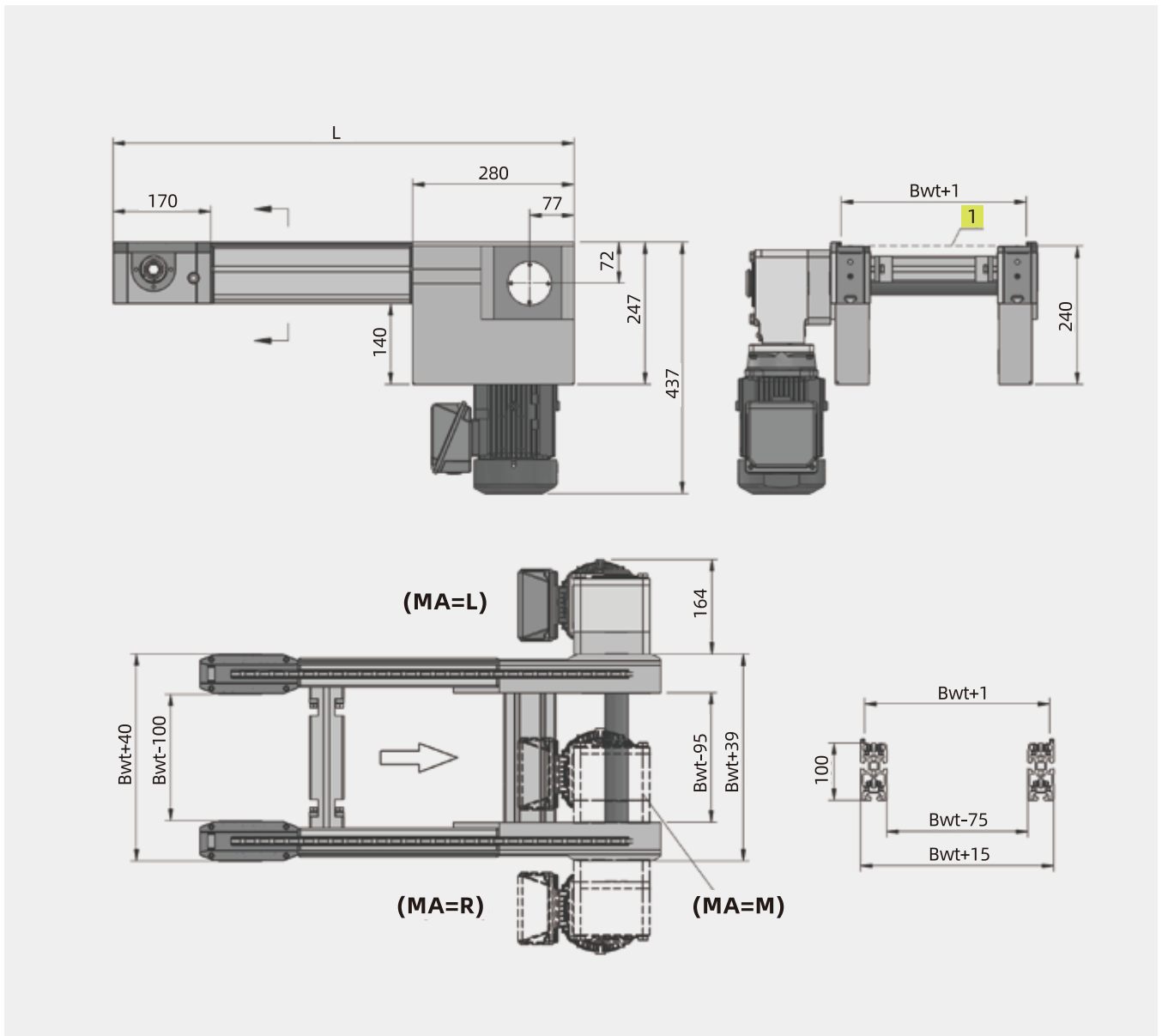

1. Surface of conveying medium

Ordering information

Conveyor medium		Accumulation roller chain with PA rollers Accumulation roller chain with steel rollers Accumulation roller chain with PA rollers and small parts protection Accumulation roller chain with steel rollers and small parts protection
Pallet width(mm)*	Bwt	160,240,320,400,480,640,800, 160≤Bwt≤1200
Conveyor length(mm)*	L	1000 < L≤30000
Nominal speed(m/min)*	V	0,6,9,12,15,18
Max. Load(kg)		2200
Drive method		Motor drive
Motor mounting way*	MA	L,R,M
Motor mounting direction		0°, 90°, 180°, 270°
Voltage*	U	220/380AC
Frequency*	f	50Hz
Motor connection*	AT	Terminal box

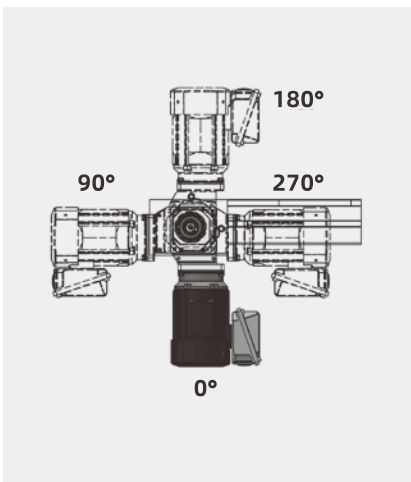

▲ Schematic diagram of motor mounting

Pallet width	Width can be customized;
Nominal speed	When V=0,no motor is configure, and other speeds can be customized;
Max. Load(kg)	Max.load can be customized;
Voltage	For other power supply voltage requirements, Please contact us for details;
Frequency	a.For other power frequency requirements,please inquire; b.Can be adjusted by frequency converter;
Motor connection	The Terminal box and outlet are shown in the figure, Please call for other requirements.

AC2、AC2/H wear strips

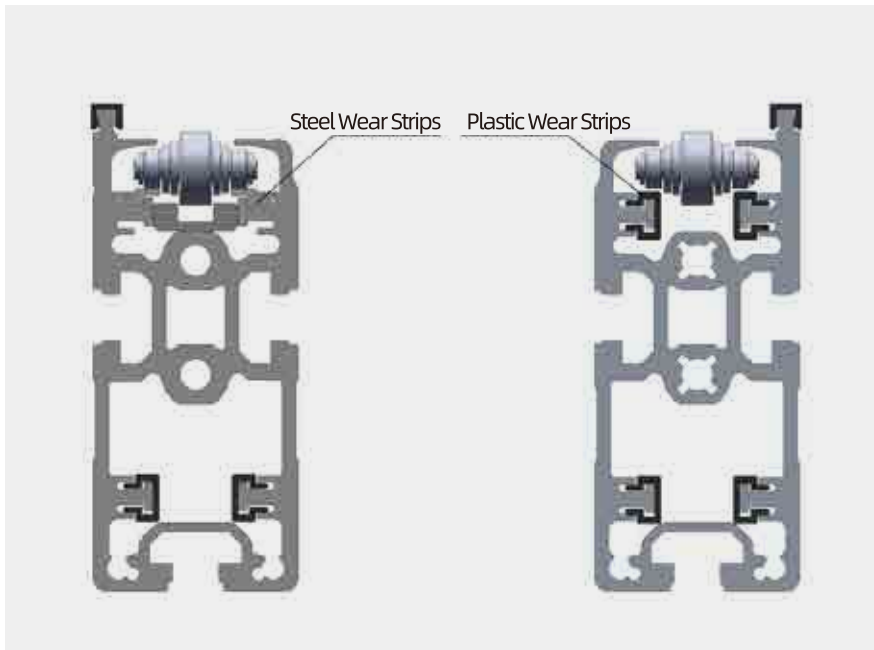

- ▶ Steel Wear Strips: Load per unit length 1.5kg/cm
- ▶ Plastic Wear Strips: Load per unit length 2kg/cm

Customized model description

AC2	Conveyor type: AC2 AC2/H
B <input type="checkbox"/>	Width: B160 / B240 / B320 / B400 / B480 / B640 / B800 / Customized
L <input type="checkbox"/>	Length: 1000 < L ≤ 30000
<input type="checkbox"/>	material of wear strips: PW SW
V <input type="checkbox"/>	Nominal speed: 01) / 6 / 9 / 12 / 15 / 18 / Customized
MA	Motor mounting way: L R M
A <input type="checkbox"/>	Motor mounting direction: 0 / 90 / 180 / 270
SP	Special requirement: <ul style="list-style-type: none"> a.Special voltage requirement b.Special Frequency requirement c.Special Terminal box and outlet requirement d.Special motor connection requirement e.Special motor mounting requirement 1)When speed is 0 , means no drive motor

Customized model example

AC2 — B240 — L2500 — PW — V12 — L — A0

Conveyor type:AC2 **Width:** Bwt=240 **Length:**L=2500 **material of wear strips:** PW **Nominal speed:** 12m/min

Motor mounting way:MA=L **Motor mounting direction:** 0° **Motor mounting direction:** None

PC2 Section

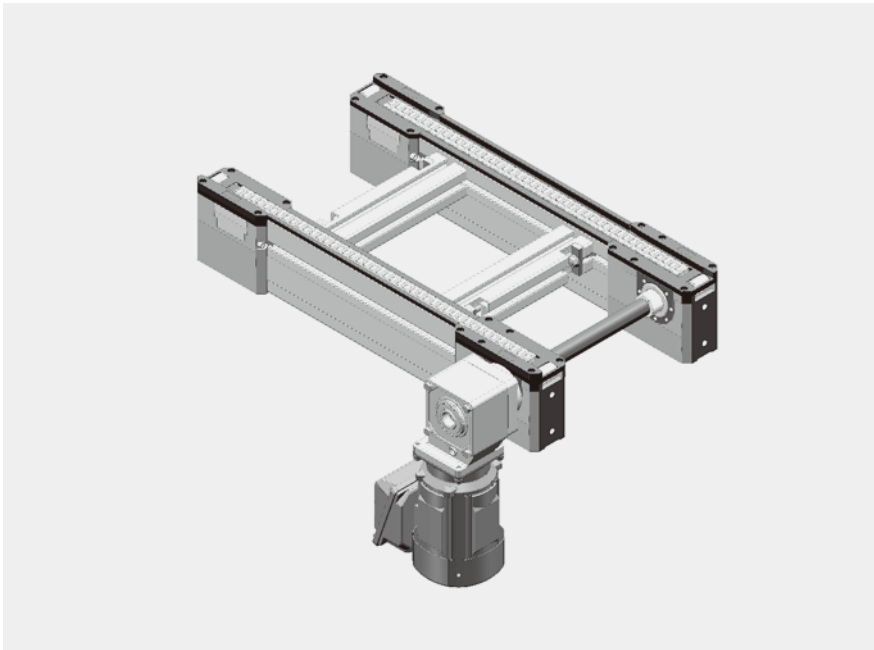

Delivery note

Recommended accessories

Connection kits
Legs
Anchor bolts
Automatic lubrication

Condition on delivery

Complete supply

- ▶ Conveyor medium: Plastic top chain
- ▶ Load limit per unit length: 0.5kg/cm
- ▶ Driven by 3-phase motors **1**, with multiple installation methods, and several installation angles, see the schematic diagram for details
- ▶ Allow accumulation operation
- ▶ Modular sets
- ▶ ESD-compatible
- ▶ Special model on request

1 1 Other types of motors are optional, please contact us for detail.

Dimensions

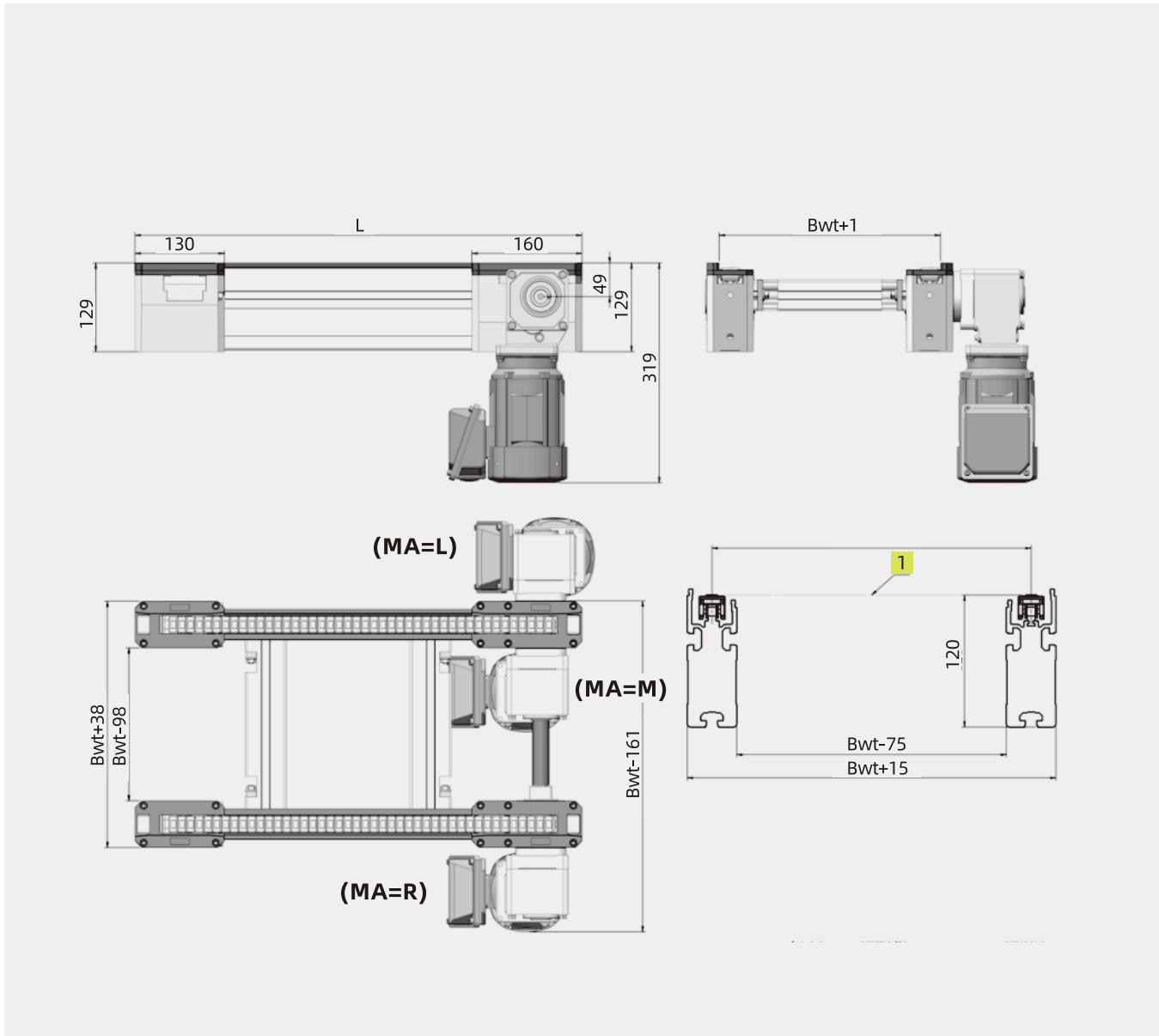

1. Surface of conveying medium

Ordering information

Conveyor medium		Plastic top chain
Pallet width (mm)*	Bwt	160,240,320,400,480,640,800, 160≤Bwt≤1200
Pallet width (mm)	Lwt	160,240,320,400,480,640,800, 160≤Bwt≤1200
Length(mm)*	L	500≤L≤8000
Nominal speed(m/min)*	V	0,6,9,12,15,18
Max. Load(kg)		200
Drive method		Motor drive
Motor mounting way*	MA	L,R,M
Motor mounting direction		0°, 90°, 180°, 270°
Voltage*	U	220/380AC
Frequency*	f	50Hz
Motor connection*	AT	Terminal box

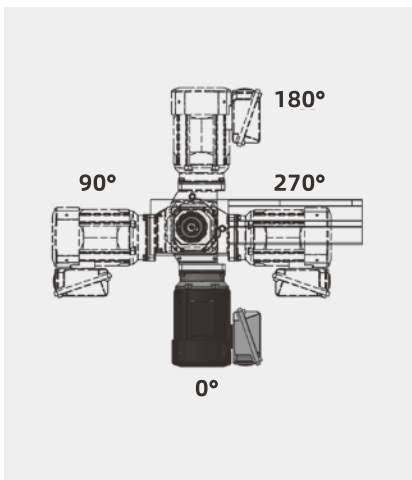

▲ Schematic diagram of motor mounting

Nominal speed	When V=0,no motor is configure, and other speeds can be customized;
Nominal speed	Max.load can be customized;
Motor mounting way	MA=M,only applicable to occasions with Bwt≥240;
Voltage	For other power supply voltage requirements, Please contact us for details;
Frequency	a.For other power frequency requirements,please inquire; b.Can be adjusted by frequency converter;
Motor connection	The Terminal box and outlet are shown in the figure, Please call for other requirements.

Customized model description

PC2	Conveyor type: PC2
B <input type="checkbox"/>	Pallet width: B240 / B320 / B400 / B480 / B640 / 800 / Customized
L <input type="checkbox"/>	Length: 500≤L≤8000
V <input type="checkbox"/>	Nominal speed: 01) / 6 / 9 / 12 / 15 / 18 /Customized
MA	Motor mounting way: L R M
A <input type="checkbox"/>	Motor mounting direction: A0 / A90 / A180 / A270
SP	Special requirement: <ul style="list-style-type: none"> a.Special voltage requirement b.Special Frequency requirement c.Special Terminal box and outlet requirement d.Special motor connection requirement e.Special motor mounting requirement <p style="color: green;">1)When speed is 0 , means no drive motor</p>

Customized model example

PC2 — B400 — L4000 — V15 — L — A0

Conveyor type: PC2 **Width:**Bwt=400 **Length:** L=4000 **Nominal speed:** 15m/min **Motor mounting way:**MA=L

Motor mounting direction: 0° **Special requirement:** None

Transmission line motor wiring diagram

△-type connection, voltage 220ac

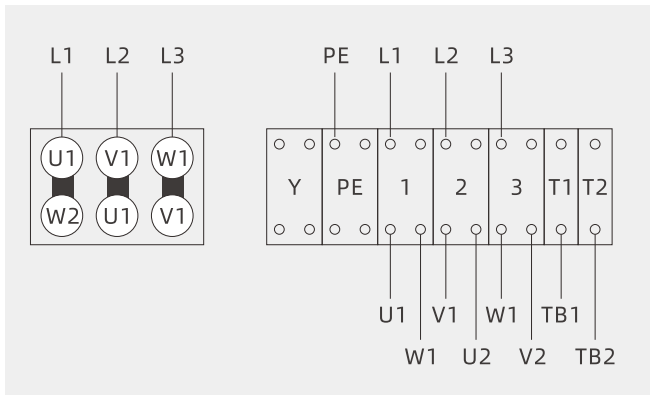

Y-type connection, voltage 380ac

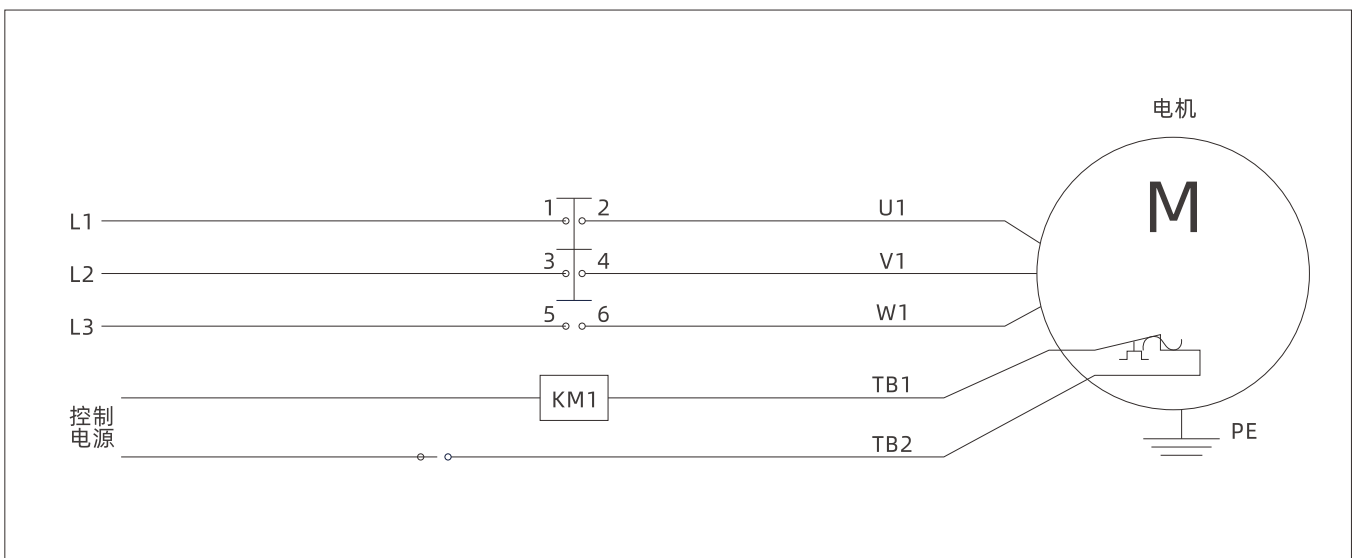
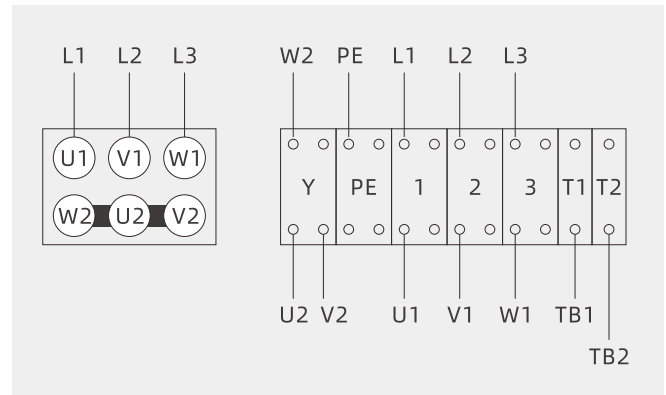

Motor connection

Special Note:

- All motors are equipped with a thermal contact, which is tripping at $150^{\circ}\text{C} \pm 5^{\circ}\text{C}$ and has to be connected to an overload switch-off. Terminals are TB1 and TB2;
- The motor is suitable for continuous operation, periodic gap operation, frequent start and stop, and forward and reverse operation;
- When the frequency converter is controlled by variable frequency speed regulation, the rated frequency of the motor is within $\pm 20\%$;
- Power supply voltage: within $\pm 10\%$ of rated voltage;
- Working environment temperature: $-20^{\circ}\text{C} - +40^{\circ}\text{C}$;
- Motor protection class IP65;
- Motor manual provided.

Motor parameter table

Conveyor type	Nominal speed (m/min)	Max. Load (kg)	Frequency (Hz)	Motor power (KW)
BC2 BC2/M	6	60	50Hz	0.2
	9	60	50Hz	0.2
	12	60	50Hz	0.2
	15	60	50Hz	0.2
	18	60	50Hz	0.2
FC2	6	250	50Hz	0.4
	9	250	50Hz	0.4
	12	250	50Hz	0.55
	15	250	50Hz	0.55
	18	250	50Hz	0.75
AC2	6	700	50Hz	0.4
	9	700	50Hz	0.4
	12	700	50Hz	0.55
	15	700	50Hz	0.55
	18	700	50Hz	0.55
AC2/H	6	2200	50Hz	0.55
	9	2200	50Hz	0.55
	12	2200	50Hz	0.75
	15	2200	50Hz	0.75
	18	2200	50Hz	0.75
PC2	6	200	50Hz	0.2
	9	200	50Hz	0.2
	12	200	50Hz	0.2
	15	200	50Hz	0.25
	18	200	50Hz	0.25

04

Positioning units

For precision operation stations, the cylinder drives pallet to a certain distance away from the conveyor surface, and the positioning pins provide the precise positioning of the pallet.

PN—Pallet guide plates

Positioning of workpiece pallets with low precision requirements

PX—Pin location

Positioning of the workpiece pallets on the machining station

PU—Positioning unit

The low height of the jacking pallet above the conveying surface makes it suitable for simple positioning operations.

PN Pallet guide plates

Pallets with low repeatability (± 0.5 mm) can be positioned using pallet guides and stops, e.g. in coarse positioning automated assembly stations.



Delivery note

Delivery Scope

guide plates
Installation of fasteners

Condition on delivery

Unassembled

Recommended accessories

Stopper

- ▶ Easy to install on conveyor sections
- ▶ Positioning on the workpiece pallet by means of a locking pit
- ▶ Works with all WA2, WE2 pallets

Dimensionst

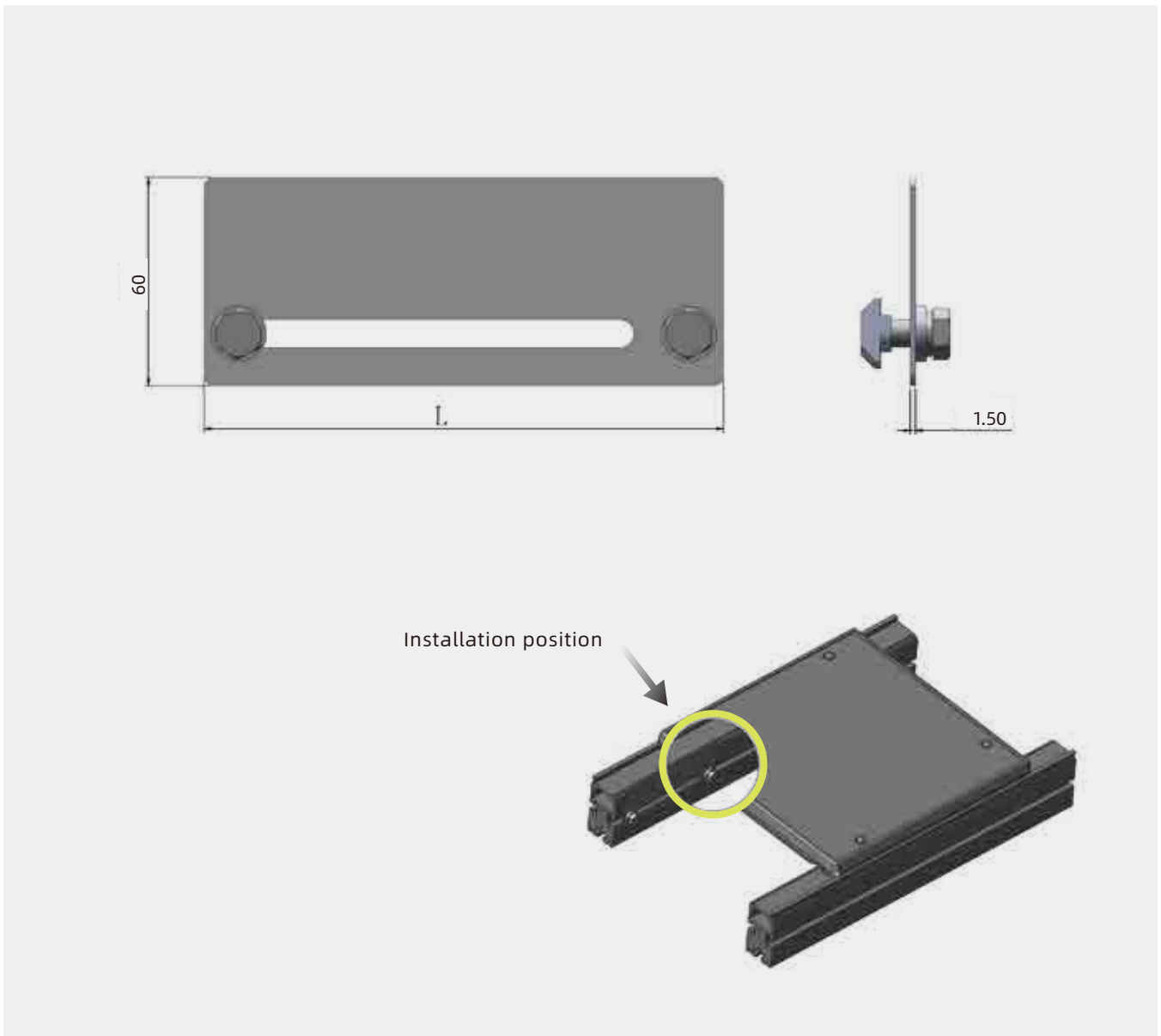

Customized model description

PN	Pallet guide plates	
Length(mm):	L □	45 / 150 / 300 / 450 / 600
Reproducing accuracy	±0.5	
Material	stainless steels	

Customized model example

PN-L150

Positioning type:PN

Length: 150

PX Pin location

Pin positioning for positioning workpiece pallets on manual/automatic machining stations

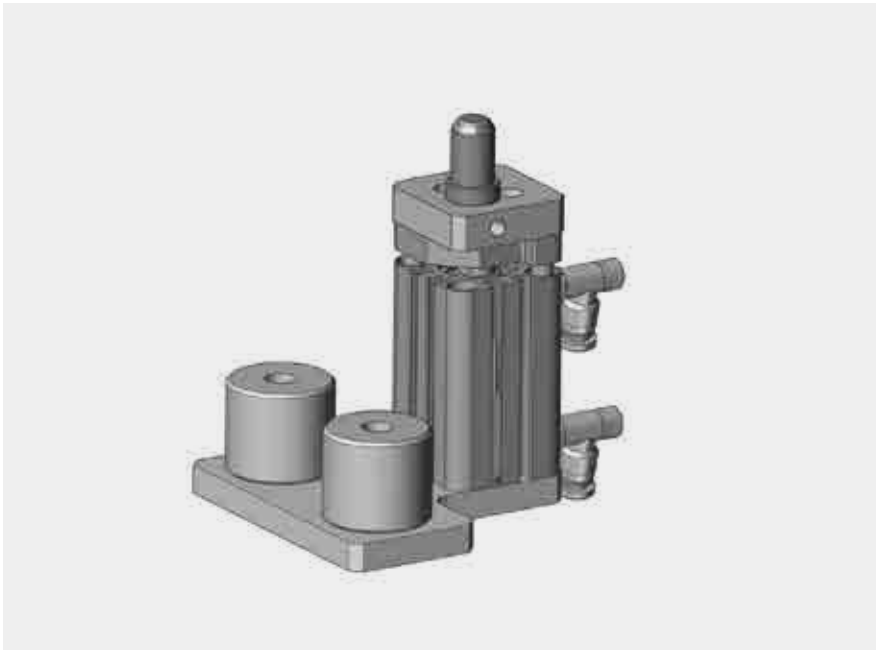

Delivery note

Delivery Scope

Positioning of sets of pins
Installation of fasteners
Speed control valve ($\phi 6$)
Magnetic Switch: D-M9B

Condition on delivery

assembled

Recommended accessories

Stopper
Solenoids

- ▶ Can be used on the left or right side
- ▶ For conveyor sections in elevators
- ▶ Can be used with WA2, WE2 pullets

Dimensionst

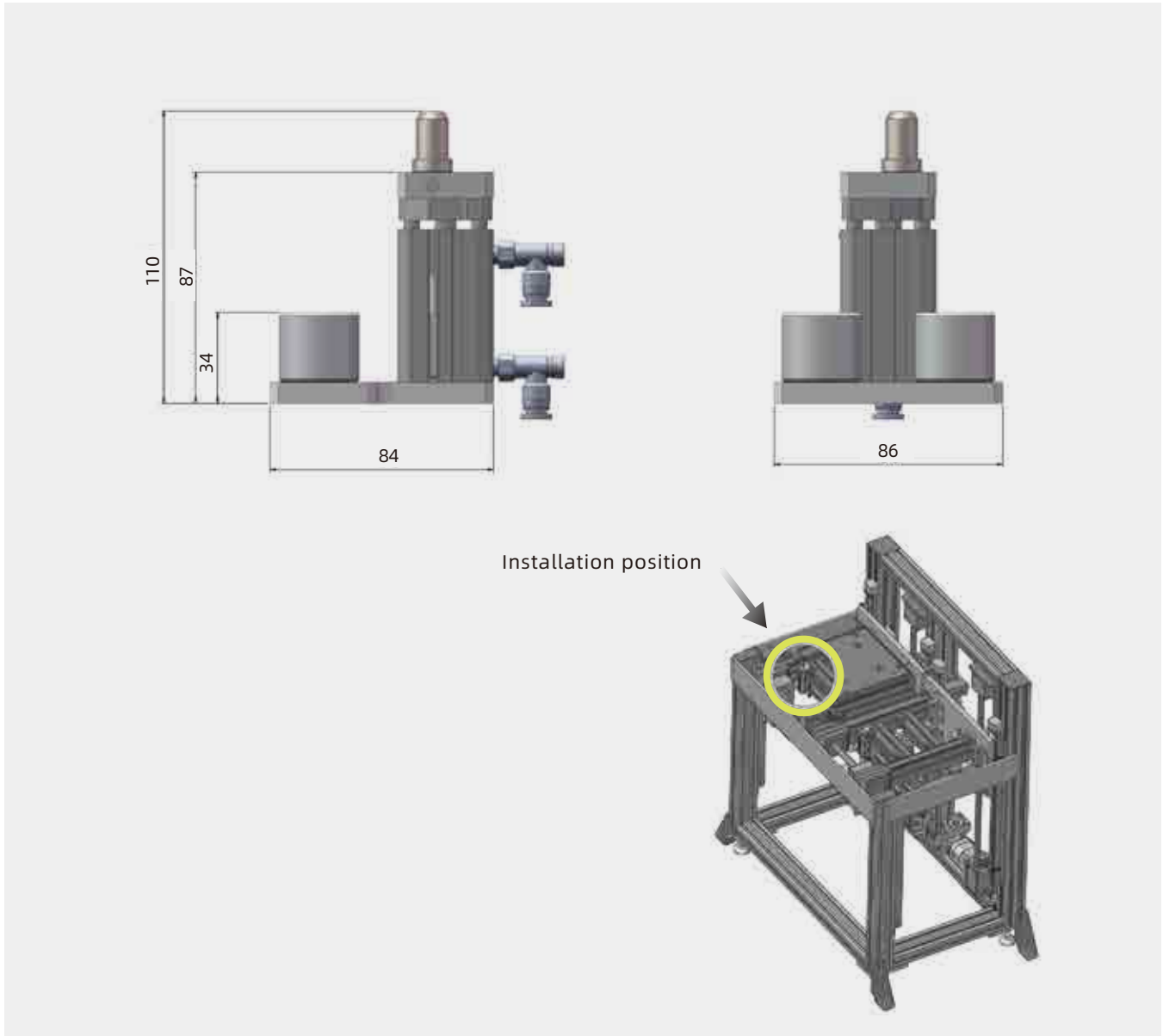

Customized model description

PX	Pin location
Installed wire body	BC2 / FC2 / AC2 / PC2
Reproducing accuracy(mm)	±0.1

Customized model example

PX-BC2

Positioning type:PX

Installed wire body:BC2

PU Positioning unit

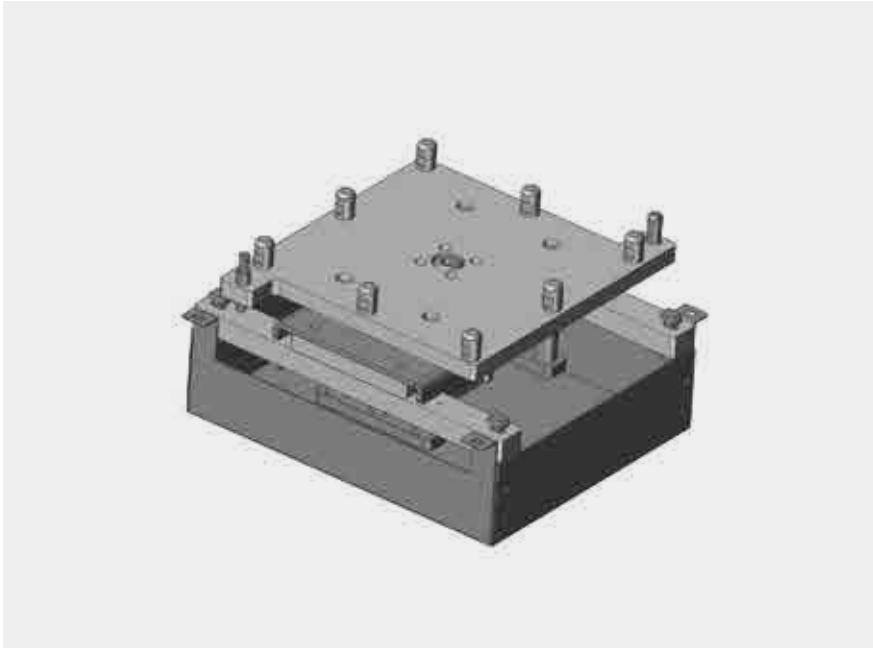

Delivery note

Delivery Scope

Positioning unit
Housing element
Magnetic Switch: D-M9B
Exhaust Throttle ($\Phi 6$)

Condition on delivery

Fully assembled
Housing element: not assembled

Recommended accessories

Stopper
Solenoid valve

- ▶ Used with stop gate to position the pallet, and suitable for the low lifting distance
- ▶ **Reproducing positioning accuracy:** ± 0.1 mm
- ▶ Combined with WA2 and WE2 workpiece pallets up to 640x640mm
Workpiece pallet lift 2.5mm above conveying surface
- ▶ **Max. Weight of pullet:** 30kg
- ▶ Special models on request

Ordering information

Track width in direction of transport(mm)*	Bwt	160,240,320,400,480,640(160≤Bwt≤640)
Conveyor length(mm)	Lwt	160,240,320,400,480,640(160≤Lwt≤640)
Conveyor length(mm)	BwtxLwt	160 x 160、240、320
		240 x 160、240、320、400
		320 x 160、240、320、400、480
		400 x 240、320、400、480
		480 x 320、400、480、640
		640 x 480、640
Max.load(kg)		30
Cylinder bore(mm)		40
Installation profile	AO	4580 profile、45100 profile
Workpiece pallet Bwt.		Special width on request
Workpiece pallet Lwt.		Special width on request

Customized model description

PU	Positioning unit
B <input type="checkbox"/>	Pallet width: B160 / B240 / B320 / B400 / B480 /Customized
L <input type="checkbox"/>	Pallet length: L160 / L240 / L320 / L400 / L480 /Customized
<input type="checkbox"/>	Conveyor type: BC2 / PC2 / FC2 / AC2
SP	Special requirement: a. Special requirements for jacking accuracy b. Special requirements for gas pipes, please call for advice

Customized model example

PU—B320—L320—BC2

Positioning unit: PU

Pallet width: Bwt=320

Pallet length: Lwt=320

Conveyor type:BC2

Special requirement: None

05

Transverse conveyor

Transverse conveyor is used to change the transfer direction of the workpiece pallet a branch can be constructed on the conveyor to connect each processing station

ET2/B—Transverse conveyor

EG—Transverse transition

ET2/B Transverse conveyor

Compensation of height differences between the main conveyor section and the traversing conveyor section

Traverse transport of workpiece pallets from and into the main conveyor section

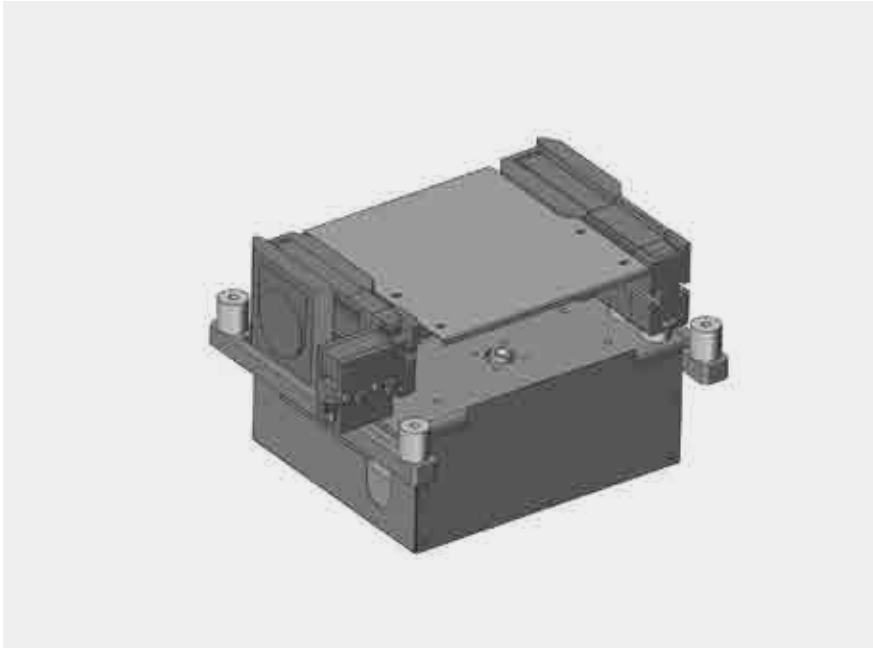

Delivery note

Delivery Scope

Transverse conveyor
Housing element
Magnetic Switch: D-M9B
Exhaust Throttle ($\Phi 6$)

Condition on delivery

Fully assembled
Housing element: not assembled

Recommended accessories

Stopper
Solenoid valve
Stepper Motor Driver

- ▶ Allow forward and reverse operation
- ▶ ·Accumulation operation not permitted
- ▶ ·Combined with WA2 and WE2 workpiece pallets up to 640*640
- ▶ **permitted surface load** : 1kg/cm
- ▶ Special models on request

Ordering information Dimensions

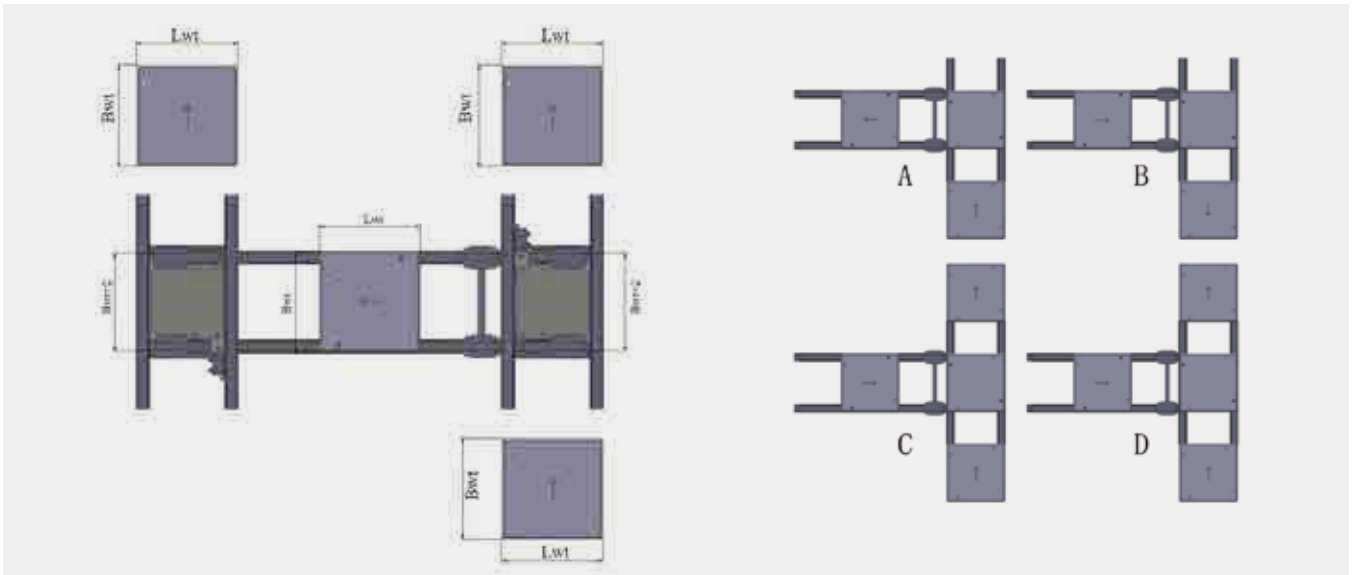

Conveyor medium		Toothed belt
Pallet width (mm)	Bwt	240,320,400,480,640 (Special width on request)
Pallet length (mm)	Lwt	240,320,400,480,640(Special length on request)
Cylinder bore(mm)		50
drive method		Stepper motor direct drive
Motor holding torque (N-m)		9.4
Stepper Motor Driver		SRX08-V (Not in scope of delivery)
voltage	U	24V

Stepper motor speed torque curve:

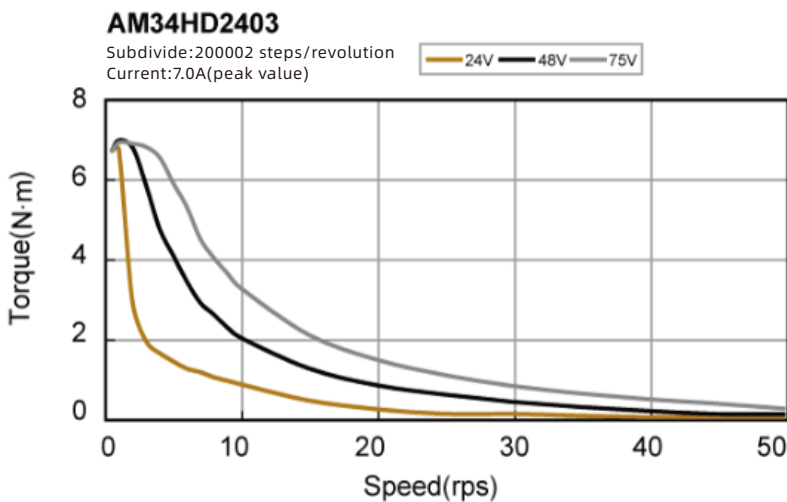

Customized model description

ET2/B	Transverse conveyor
B <input type="checkbox"/>	Pallet width: B240 / B320 / B400 / B480 / B640 / 定制
L <input type="checkbox"/>	Pallet length: L240 / L320 / L400 / L480 / L640 / 定制
<input type="checkbox"/>	Conveyor type: BC2 / PC2 / FC2 / AC2
SP	Special requirement: a.Special accuracy requirement b.Special airway requirement c. Special wiring requirements d. Special requirements for motor power supply connection

Customized model example

ET2/B—B320—L320—BC2

Traverse unit type: ET2/B

Pallet width: Bwt=320

Pallet length: Lwt=320

Conveyor type:BC2

Special requirement:None

EG Transverse transition

The transverse transition unit is used in conjunction with two lifting traverse units to transport pallets of workpieces between parallel conveyor lines.

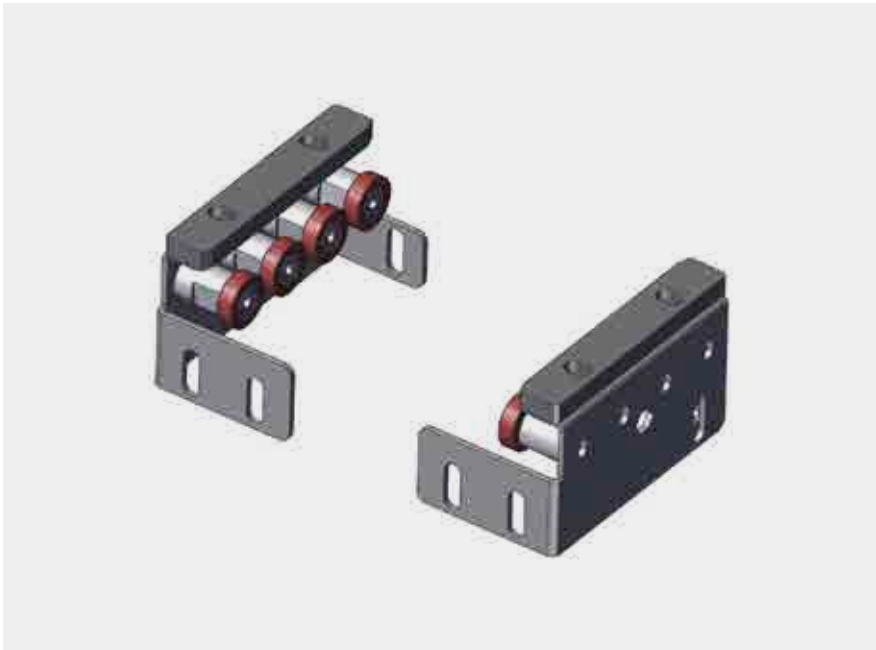

Delivery note

Delivery Scope

Positioning of sets of pins
Installation of fasteners

Condition on delivery

Fully assembled
assembled

- ▶ Transverse transition unit for transverse transport of workpiece pallets between two parallel conveyor lines
- ▶ No separate drive
- ▶ **Conveying medium:** polyurethane rubber-coated wheel
- ▶ Allow forward and reverse operation
- ▶ Combined with WA2 and WE2 workpiece pallets
- ▶ For transverse conveying
- ▶ It can also be used as an inclined passive conveying section

Dimensions

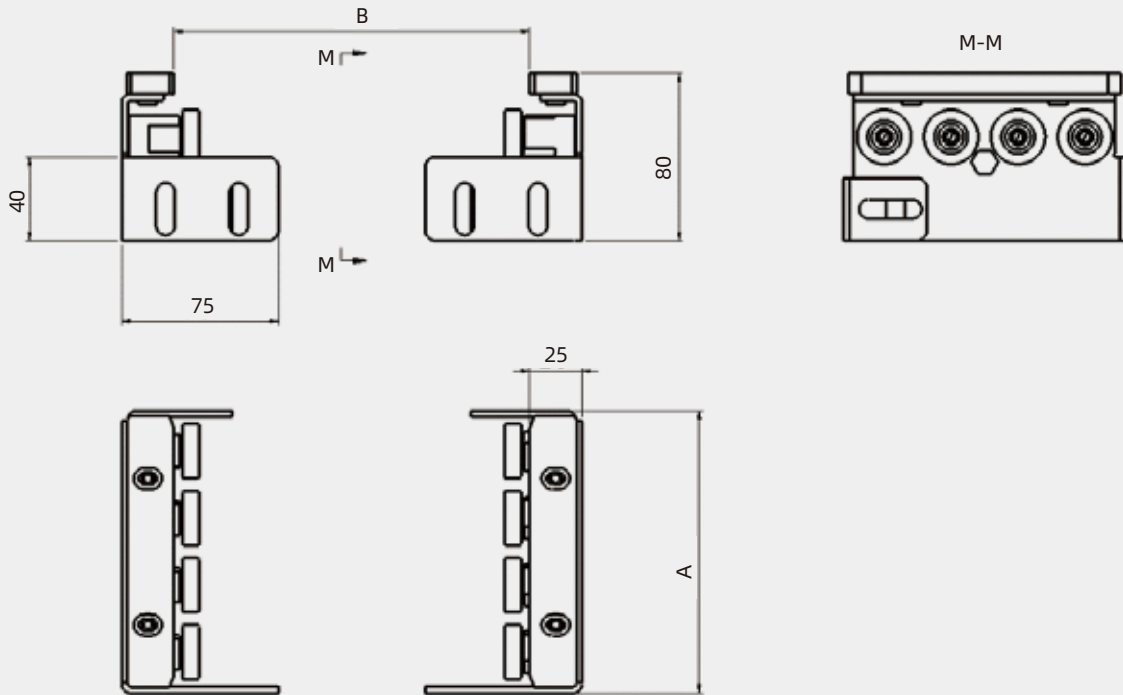

Installation position



Customized model description

EG	Transverse transition
L <input type="checkbox"/>	Conveyor line spacing: L45 / L90 / L115 / L135 / L145 /Customized
SP	Special requirement: a.Change of conveying medium

Customized model example

EG-L90

Positioning type:EG

Conveyor line spacing:L=90

Special requirement: None

06

Rotate units

Rotate unit can turn the workpiece pallet to the required position

On cycle lines without bends, this ensures that the pallet orientation of the workpieces is always correct

That is, the front end is always the front end

PR— Rotate units

PR Rotate units

Rotate unit can turn the workpiece pallet to the required position

On cycle lines without bends, this ensures that the pallet orientation of the workpieces is always correct. That is, the front end is always the front end

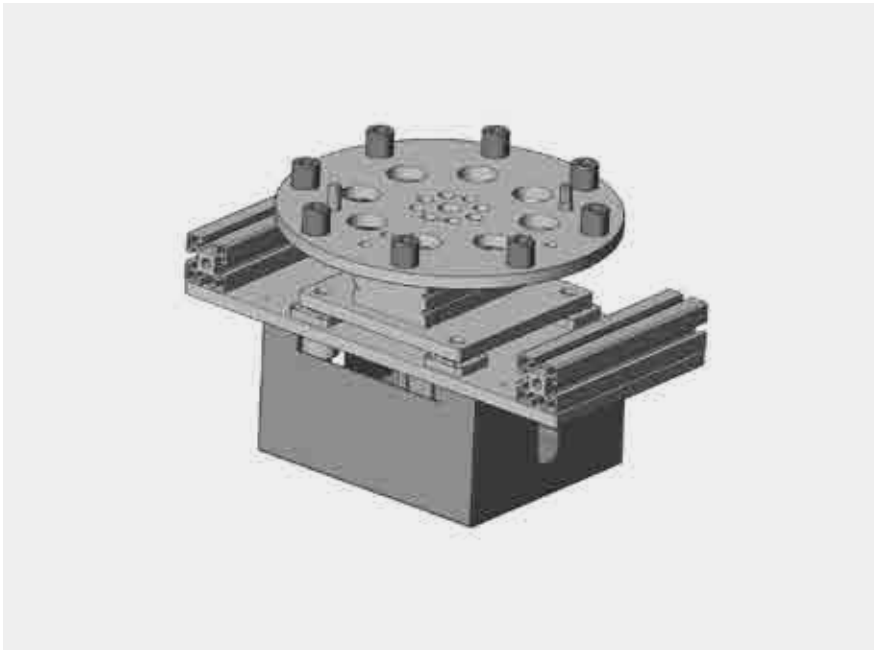

Delivery note

Delivery Scope

Rotate units
Housing element
Installation of fasteners
Magnetic Switch: D-M9B
Exhaust Throttle ($\Phi 6$)

Condition on delivery

Fully assembled
Housing element: not assembled

Recommended accessories

Stopper
Solenoid valve

- ▶ In combination with a stopper, the conveyor pallet is rotated by 90° or 180° on the conveyor line.
- ▶ Suitable for environments with special requirements for pallet conveying direction
- ▶ Combined with WA2 and WE2 workpiece pallets up to 640*640
- ▶ Does not change the direction of conveyance of the pallet
- ▶ Workpiece pallet lift 25mm above conveying surface
Special models on request

Dimensions

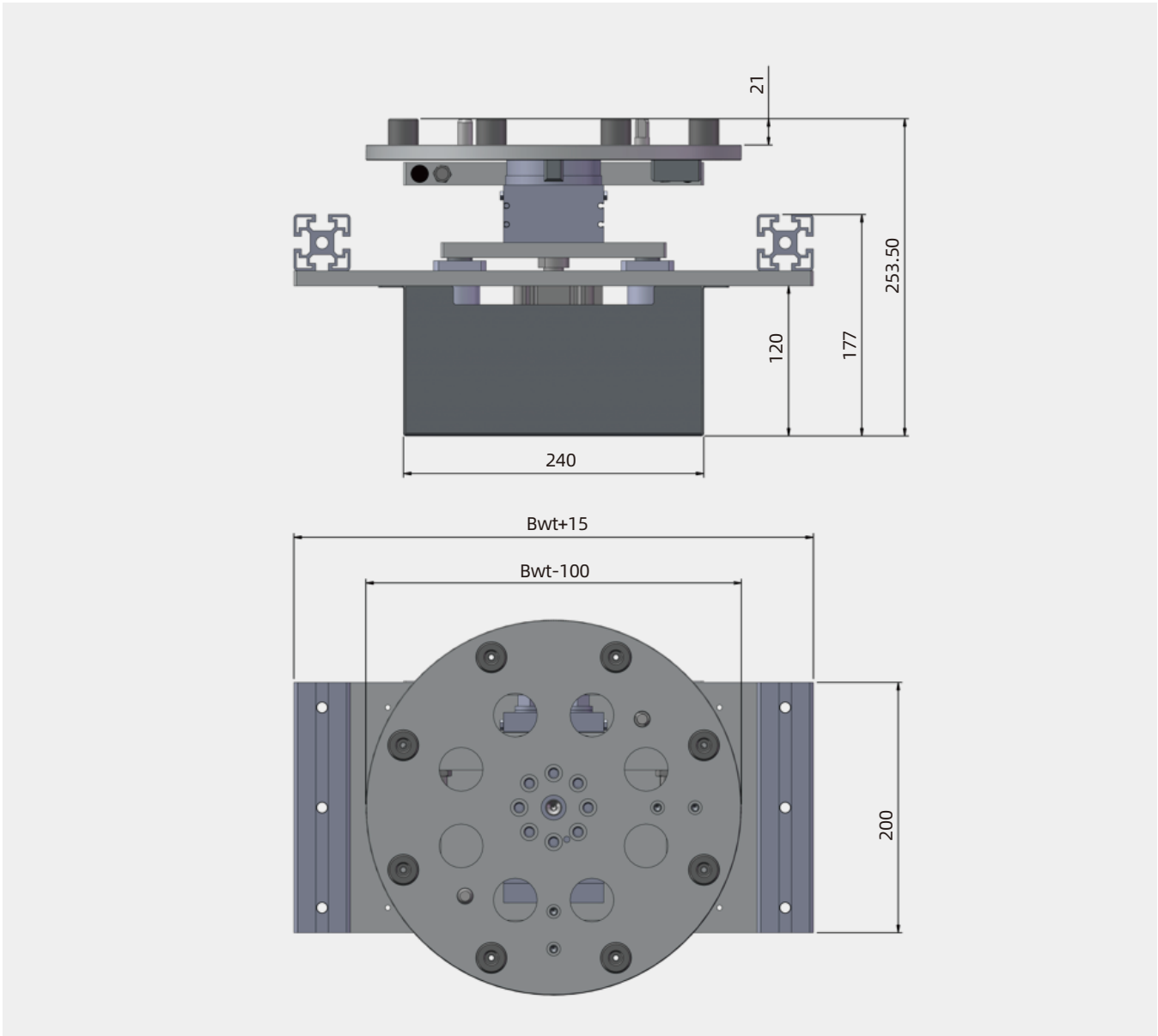

Ordering information

Track width in direction of transport(mm)*	Bwt	240,320,400,480,640(240≤Bwt≤640)
Conveyor length(mm)	Lwt	240,320,400,480,640(240≤Lwt≤640)
组合方式(mm)	BwtxLwt	240 x 240、320、400
		320 x 240、320、400、480
		400 x 240、320、400、480
		480 x 320、400、480、640
		640 x 640
Max.load(kg)		30
Cylinder bore(mm)		50
Installation profile		4580 profile、45100 profile
Pallet rotation angle		90°、180°
Workpiece pallet Bwt.		Special width on request
Workpiece pallet Lwt.		Special width on request

Customized model description

PR	Rotate units
B <input type="checkbox"/>	Pallet width: B240 / B320 / B400 / B480 / B640 / Customized
L <input type="checkbox"/>	Pallet length: L240 / L320 / L400 / L480 / L640 / Customized
<input type="checkbox"/>	Conveyor Line Type: 90° 180°
SP	Special requirement: a.Special accuracy requirement b.Special airway requirement

Customized model example

PR—B320—L320—90

Rotate units:PR

Pallet width:Bwt=320

Pallet length:Lwt=320

Rotation angle:90°

Special requirement: None

07

Curves

Curves are used to change the direction of workpiece pallet and maintains the original positioning of the workpiece (the front end is always the front end)

KV/90 Curve

90°curve conveying of the workpiece pallet with driving round belt
For toothed belt and flat belt conveyor;

KV/180 Curve

180°curve conveying of the workpiece pallet with driving round belt
For toothed belt and flat belt conveyor;

CV/90 Curve

90°curve conveying of the workpiece pallet with driving flat top chain
For top chain and roller chain conveyor;

CV/180 Curve

180°curve conveying of the workpiece pallet with driving flat top chain
For top chain and roller chain conveyor;

QV/forced curve

90°curve conveying of the workpiece pallet with driving toothed belt
For toothed belt and flat belt conveyo.

KV/90 Curve

90°curve conveying of the workpiece pallet with driving round belt

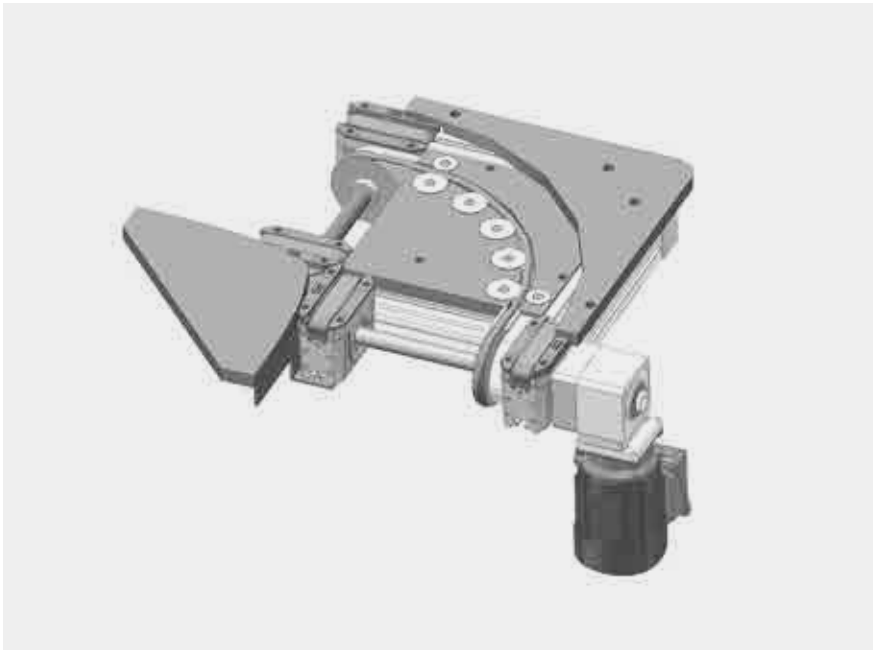

Delivery note

Recommended accessories

Legs
Connection kit

Delivery involved

Curve with Motor

Condition on delivery

Partial assembled
Baffle: not assembled
Motor: not assembled

- ▶ 90°curve conveying left or right
- ▶ Will not change the conveying direction of workpiece pallet
- ▶ **Conveyor medium:** round belt
- ▶ **Environment condition:** no grease and no oil
- ▶ The motor is mounted at the end of the curve conveying direction
- ▶ **Max.load:**20kg
- ▶ ESD-compatible
- ▶ Special models on request

- ▶ **Special note:**accumulation operation not permitted
KV/90 Curve,
There are independent toothed belt drive units at both ends of the curve,which can be used
for the extended design of the toothed belt section

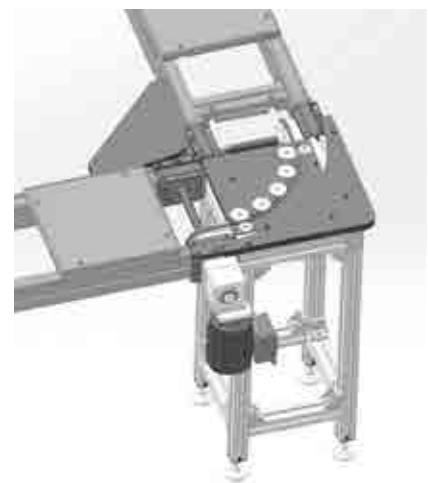

Dimensions

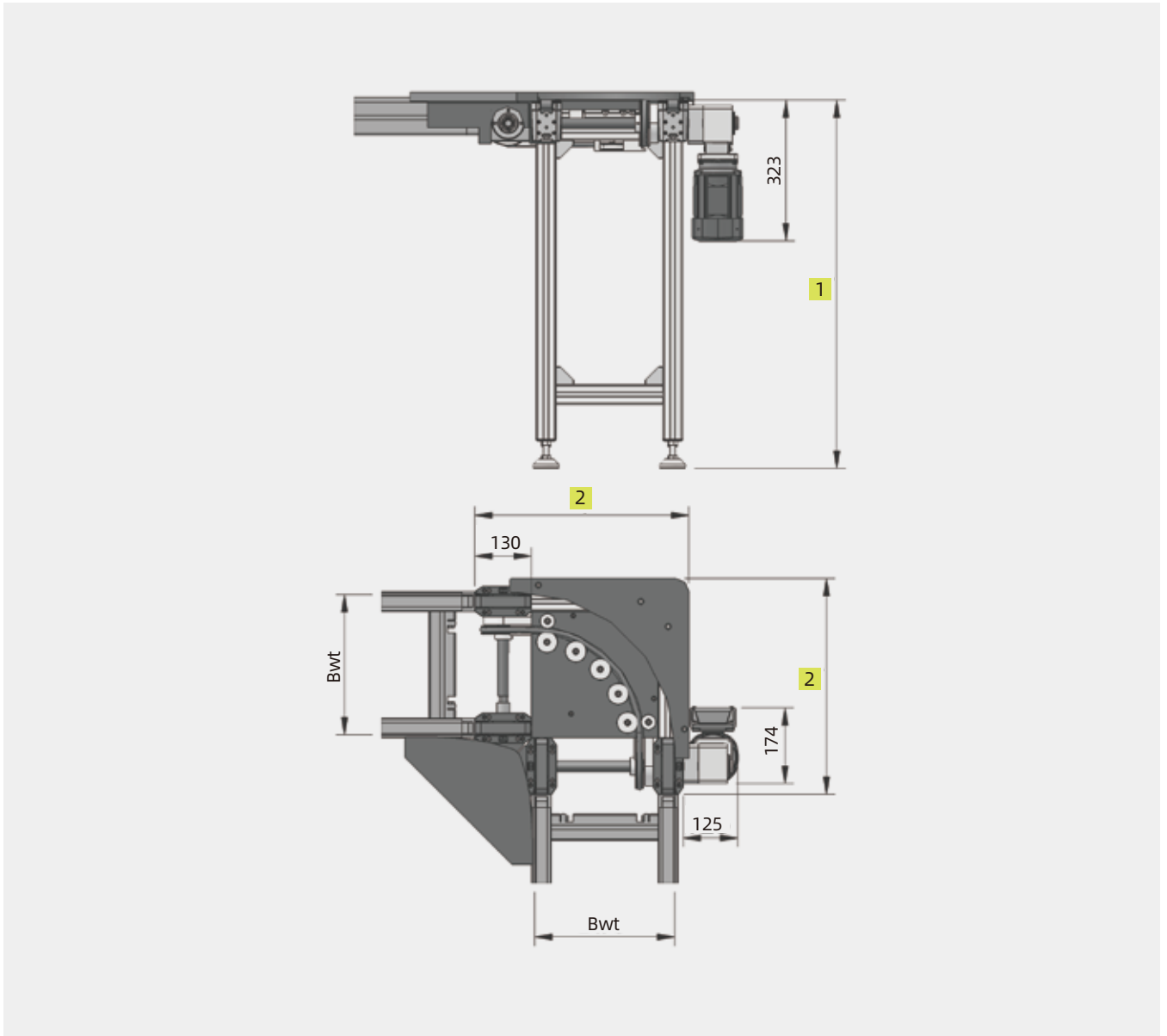

1 Customized

2 Base on size of workpiece pallet

Ordering information

Track width in direction of transport(mm)*	Bwt	160,240,320,400,480(160≤Bwt≤480)
Length in direction of transport(mm)*	Lwt	160,240,320,400,480(160≤Bwt≤480)
Combination options(mm)	Bwt×Lwt	160 x 160、240、320
		240 x 160、240、320、400
		320 x 160、240、320、400、480
		400 x 240、320、400、480
		480 x 320、400、480
Max. Load(kg)		20
Nominal speed(m/min)*	V	0,6,9,12,15,18
Motor mounting way*	MA	L,R,M
Curve direction		C0/CL
Voltage*	U	220/380AC
Frequency*	f	50Hz
Motor connection*	AT	Terminal box

Track width in direction of transport	Special width on request;
Length in direction of transport	Special width on request;
Nominal speed	When V=0,no motor is configured,and other speeds can be customized;
Max. Load(kg)	Special max,load on request;
Motor mounting way	MA=M,only applicable to occasion with Bwt≥320
Voltage	For other power supply voltage requirements,please contact us for details;
Frequency	a.For other power frequency requirements,please inquire; b.Can be adjusted by frequency converter;
Motor connection	The Terminal box and outlet are shown in the figure; Please call for other requirement.

KV/180 Curve

180°curve conveying of the workpiece pallet with driving round belt

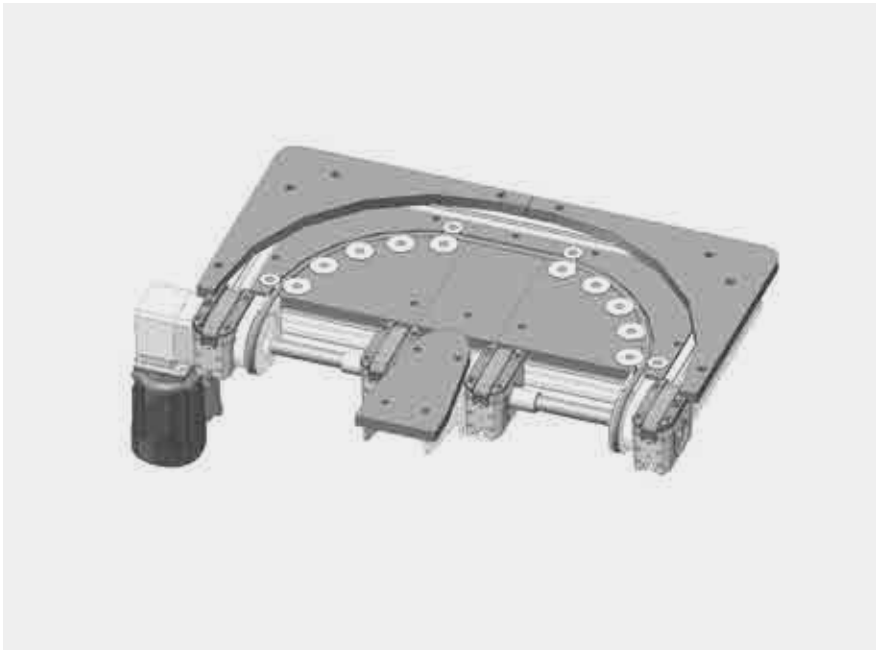

Delivery note

Recommended accessories

Legs
Connection kit

Delivery involved

Curve with Motor

Condition on delivery

Partial assembled
Baffle: not assembled
Motor: not assembled

- ▶ 180°curve conveying left or right
 - ▶ Will not change the conveying direction of workpiece pallet
 - ▶ **Conveyor medium:** round belt
 - ▶ **Environment condition:** no grease and no oil
 - ▶ The motor is mounted at the end of the curve conveying direction
 - ▶ **Max.load:** 20kg
 - ▶ ESD-compatible
 - ▶ Special models on request

 - ▶ **Special note:** accumulation operation not permitted
- KV/180 Curve
- There are independent toothed belt drive units at both ends of the curve, which can be used for the extended design of the toothed belt section



Dimensions

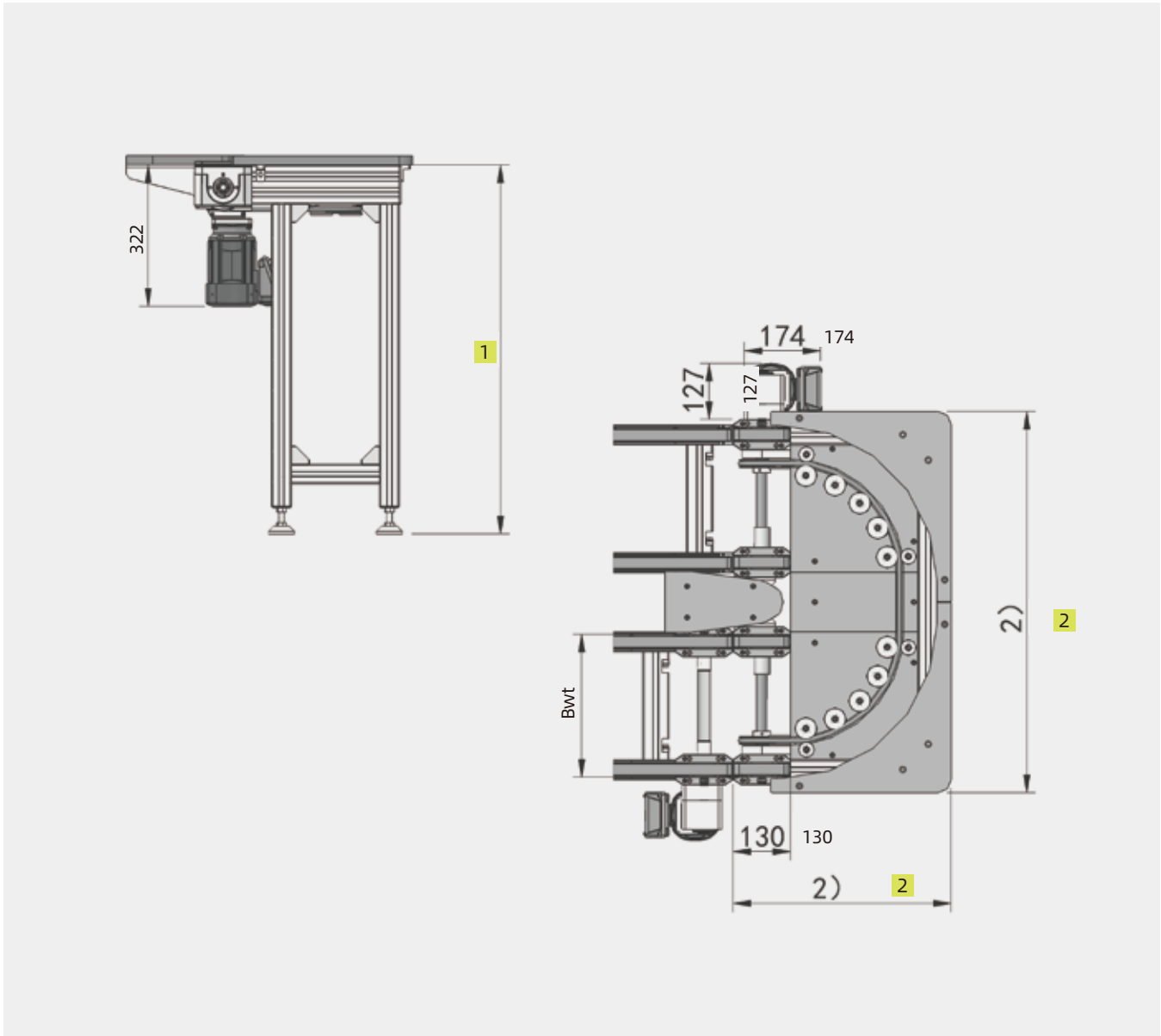

1 Customized

2 Base on size of workpiece pallet

Ordering information

Track width in direction of transport(mm)*	Bwt	160,240,320,400, 480 160≤Bwt≤400
Length in direction of transport(mm)*	Lwt	160,240,320,400, 480 160≤Lwt≤400
Combination options(mm)	Bwt×Lwt	160 x 160、240、320
		240 x 160、240、320、400
		320 x 160、240、320、400, 480
		400 x 240、320、400, 480
		480 x 320、400, 480
Max. Load(kg)		20
Nominal speed(m/min)*	V	0,6,9,12,15,18
Distance between conveyors*	a	90 , 135
Motor mounting way*	MA	L,R,M
Curve direction		C0/CL
Voltage*	U	220/380AC
Frequency*	f	50Hz
Motor connection*	AT	Terminal box

Track width in direction of transport	Special width on request;
Length in direction of transport	Special width on request;
Nominal speed	When V=0,no motor is configured,and other speeds can be customized;
Max. Load(kg)	Special max,load on request;
Motor mounting way	MA=M,only applicable to occasion with Bwt≥320
Voltage	For other power supply voltage requirements,please contact us for details;
Frequency	a.For other power frequency requirements,please inquire; b.Can be adjusted by frequency converter;
Motor connection	The Terminal box and outlet are shown in the figure; Please call for other requirement.

CV/90 Curve

90°curve conveying of the workpiece pallet with driving plastic flat top chain



Delivery note

Recommended accessories

Legs
Connection kit
Foundation bracket

Delivery involved

Curve with Motor
(including drive motor)

Condition on delivery

Fully assembled

- ▶ 90°curve conveying left or right
- ▶ ·Will not change the conveying direction of workpiece pallet
- ▶ Conveyor medium: Plastic flat top chain
- ▶ Motor power optional
- ▶ Automatic lubrication optional
- ▶ Extended section can be added to both ends of the curve when needed
After extension,the load limit of the drive cannot be exceeded
- ▶ Special models on request

Dimensions

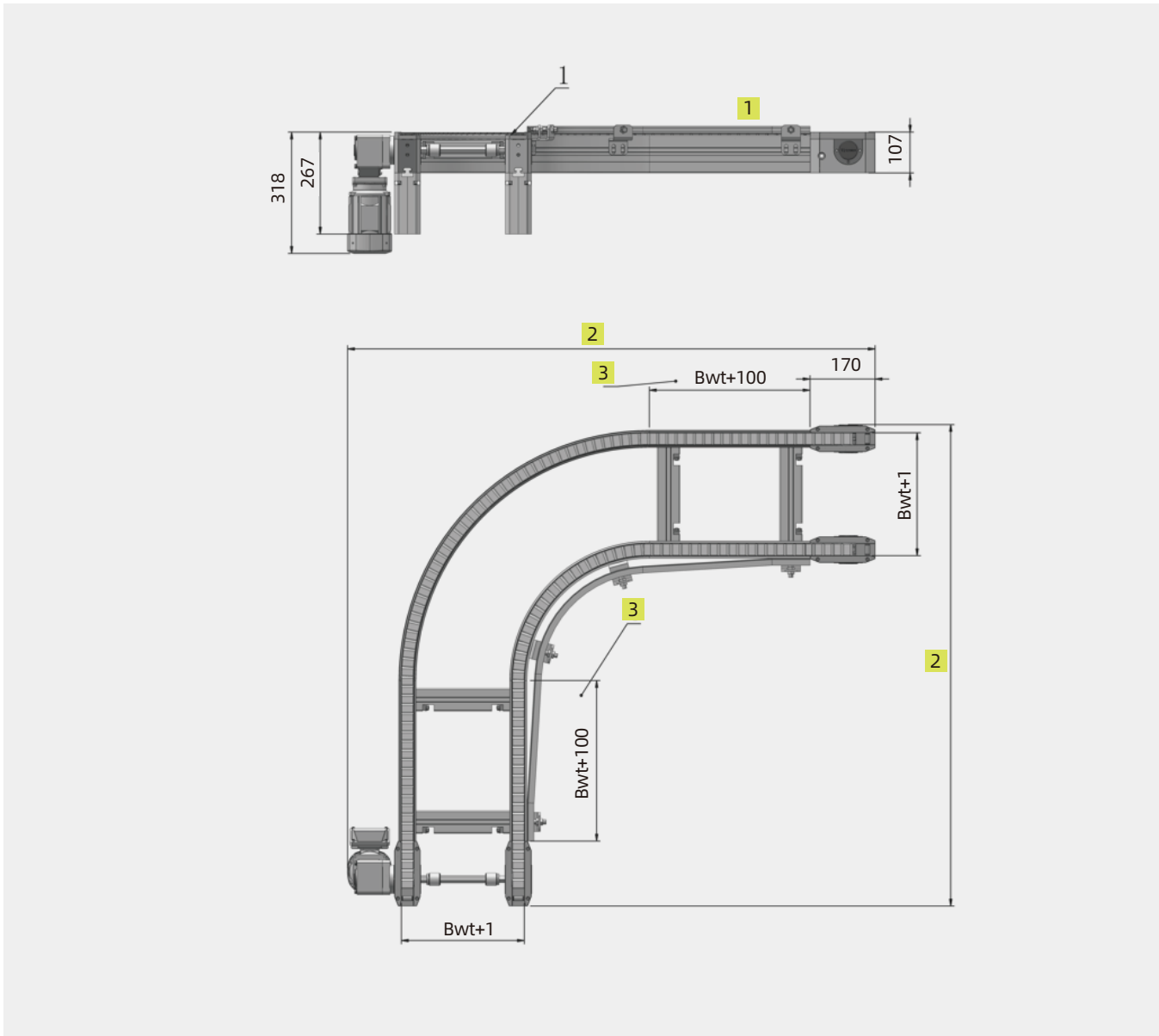

- 1 Customized
- 2 Base on size of workpiece pallet
- 3 Special models on request

Ordering information

Track width in direction of transport(mm)*	Bwt	160,240,320,400,480,640,800(160≤Bwt≤800)
Length in direction of transport(mm)*	Lwt	160,240,320,400,480,640,800,1040(160≤Bwt≤1040)
组合方式(mm)	BwtxLwt	160 x 160、240、320
		240 x 160、240、320、400
		320 x 160、240、320、400、480
		400 x 240、320、400、480
		480 x 320、400、480、640
		640 x 640、800
Max. Load(kg)		90
Nominal speed(m/min)*	V	0,6,9,12,15,18
Motor mounting way*	MA	L, R, M
Curve direction		C0/ CL
Voltage*	U	220/380AC
Frequency*	f	50Hz
Motor connection*	AT	Terminal box

Track width in direction of transport	Special width on request;
Length in direction of transport	Special width on request;
Nominal speed	When V=0,no motor is configured,and other speeds can be customized;
Max. Load(kg)	Special max.load on request;
Motor mounting way	MA=M,only applicable to occasion with Bwt≥240
Voltage	For other power supply voltage requirements,please contact us for details;
Frequency	a.For other power frequency requirements,please inquire; b.Can be adjusted by frequency converter;
Motor connection	The Terminal box and outlet are shown in the figure; Please call for other requirement.

CV/180 Curve

180°curve conveying of the workpiece pallet with driving plastic flat top chain



Delivery note

Recommended accessories

Legs
Connection kit
Foundation bracket

Delivery involved

Curve with Motor
(including drive motor)

Condition on delivery

Fully assembled

- ▶ **Conveyor medium:** Plastic flat top chain
- ▶ 180°curve conveying left or right
- ▶ Will not change the conveying direction of workpiece pallet
- ▶ Motor power optional
- ▶ Automatic lubrication optional
- ▶ Extended section can be added to both ends of the curve when needed
After extension, the load limit of the drive cannot be exceeded
- ▶ Special models on request

Dimensions

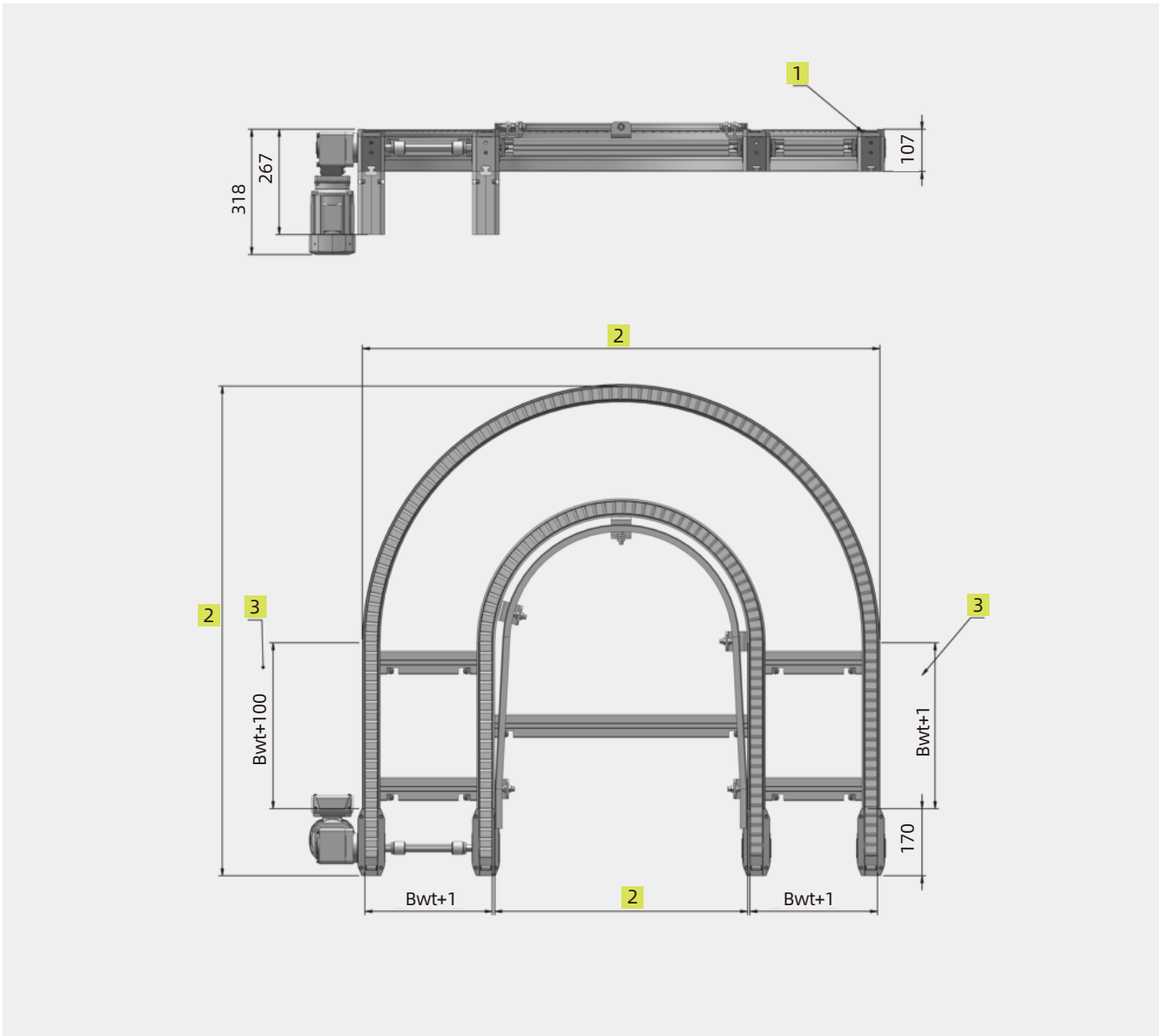

- 1 Customized
- 2 Base on size of workpiece pallet
- 3 Special models on request

Ordering information

Track width in direction of transport(mm)*	Bwt	160,240,320,400,480,640,800(160≤Bwt≤800)
Length in direction of transport(mm)*	Lwt	160,240,320,400,480,640,800(160≤Bwt≤800)
Combination options(mm)	BwtxLwt	160 x 160、240、320
		240 x 160、240、320、400
		320 x 160、240、320、400、480
		400 x 240、320、400、480
		480 x 320、400、480、640
		640 x 640、800
Max. Load(kg)		60
Nominal speed(m/min)*	V	0,6,9,12,15,18
Motor mounting way*	MA	L , R , M
Curve direction		C0/ CL
Voltage*	U	220/380AC
Frequency*	f	50Hz
Motor connection*	AT	Terminal box

Track width in direction of transport	Special width on request;
Length in direction of transport	Special width on request;
Nominal speed	When V=0,no motor is configured,and other speeds can be customized;
Max. Load(kg)	Special max.load on request;
Motor mounting way	MA=M,only applicable to occasion with Bwt≥240
Voltage	For other power supply voltage requirements,please contact us for details;
Frequency	a.For other power frequency requirements,please inquire; b.Can be adjusted by frequency converter;
Motor connection	The Terminal box and outlet are shown in the figure; Please call for other requirement.

Customized model description

CV/90	Curve type: CV/90 CV/180
B <input type="checkbox"/>	Pallet width: B160 / B240 / B320 / B400 / B480 / B640 / B800 / Customized
L <input type="checkbox"/>	Pallet length: L160 / L240 / L320 / L400 / L480 / L640 / L800 / Customized
V <input type="checkbox"/>	Nominal speed: 01) / V6 / V9 /V12 / V15 / V18 / Customized
<input type="checkbox"/>	Curve direction: C0 / CL
MA	Motor mounting way: L,R,M
SP	Special requirement: a.Special voltage requirement b.Special Frequency requirement c.Special Terminal box and outlet requirement d.Special motor connection requirement e.Special motor mounting requirement 1) When speed is 0,means no drive motor

Customized model example

CV/90-B320-L320-V12-C0-L

Curve type: CV/90 **Pallet width:**Bwt=320 **Pallet length:**Lwt=320 **Nominal speed:**12 m/min

Curve direction: C0 **Motor mounting way:** MA=L **Special requirement:**None

QV Forced Curve

90°curve conveying of the workpiece pallet with driving toothed belt

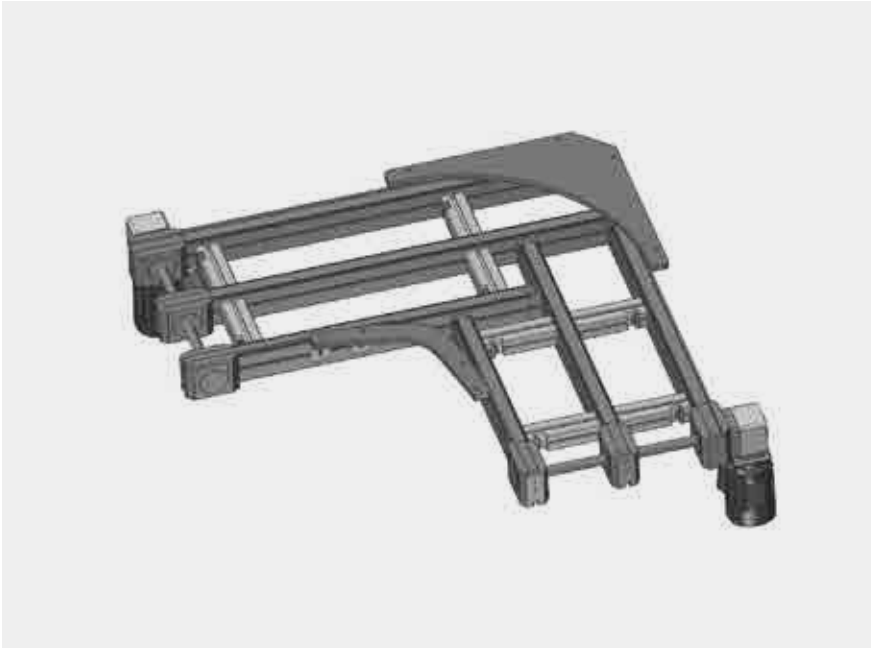

Delivery note

Recommended accessories

Connection kit

Legs

Foundation Bracket

Condition on delivery

Fully assembled

- ▶ Conveyor medium: Toothed belt
- ▶ 90°curve conveying left or right
- ▶ Will not change the conveying direction of workpiece pallet
- ▶ Motor power optional
- ▶ Load limit per unit length: 1 kg/cm
- ▶ Driven by 3-phase motors 1) ,with multiple installation methods,and several installation angles,see the schematic diagram for details
- ▶ unstackable operation
- ▶ Meets anti-static requirements
- ▶ Special models on request

Dimensions

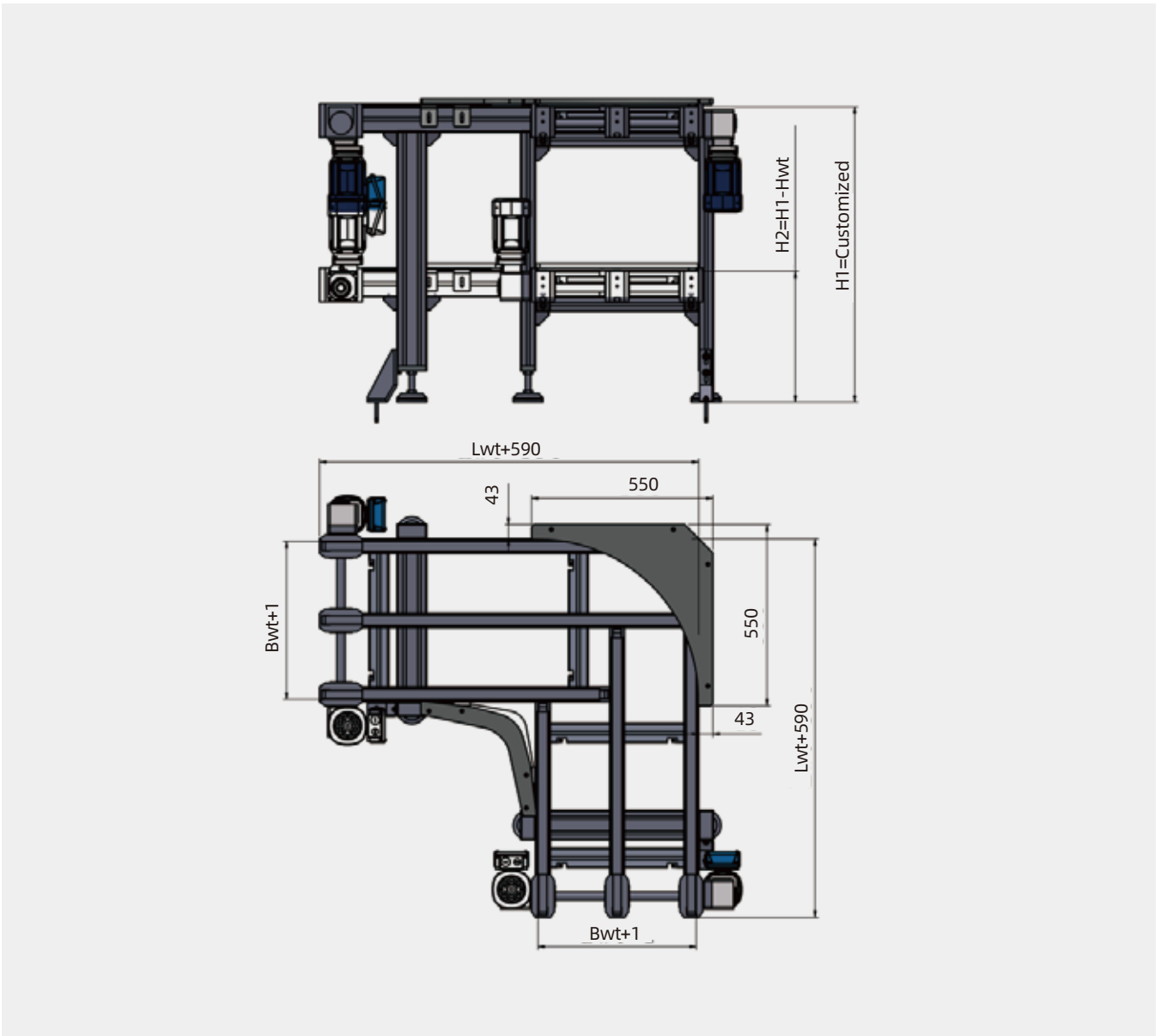

Hwt - height difference between the upper and lower levels of the conveyor line
 Can be done in single layer

Ordering information

Conveyor medium		Toothed belt
Pallet width(mm)*	Bwt	240,320,400,480,640,800 (Special width on request)
Pallet length(mm)*	Lwt	240,320,400,480,640,800 (Special length on request)
Nominal speed(m/min)*	V	0,6,9,12,15,18
Load limit per unit length (kg/cm)		1
drive method		Direct motor drive
Motor mounting way*	MA	L,R
Motor mounting direction		0°, 90°, 180°, 270°
Voltage*	V	220/380AC
Frequency*	f	50Hz
Motor connection*	AT	Terminal box

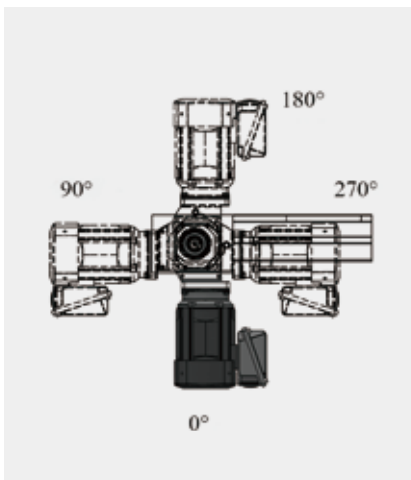

▲ Schematic diagram of motor mounting

Nominal speed	When V=0,no motor is configured, and other speeds can be customized;
Voltage	For other power supply voltage requirements, please contact us for details;
Frequency	a.For other power frequency requirements,please inquire; b.Can be adjusted by frequency converter;
Motor connection	The Terminal box and outlet are shown in the figure; Please call for other requirement.

Customized model description

QV	Curve type: forced curve
B <input type="checkbox"/>	Pallet width: B240 / B320 / B400 / B480 / B640 / B800 / Customized
L <input type="checkbox"/>	Pallet length: L240 / L320 / L400 / L480 / L640 / L800 / Customized
V <input type="checkbox"/>	Nominal speed: 01) / 6 / 9 / 12 / 15 / 18 / Customized
MA	Motor mounting way: L ,R
A <input type="checkbox"/>	Motor mounting angle: 0 / 90 / 180 / 270
SP	Special requirement: a.Special voltage requirement b.Special Frequency requirement c.Special Terminal box and outlet requirement d.Special motor connection requirement e.Special motor mounting requirement 1) When speed is 0,means no drive motor

Customized model example

QV—B320—L320—V15—L—A0

Curve type:QV **Pallet width:**Bwt=320 **Pallet length:** Lwt=320 **Nominal speed:** 15 m/min

Motor mounting angle: 0° **Motor mounting way:** MA=L **Special requirement:**None

Forced curve parameter table

Curve type	Nominal speed (m/min)	Max. Load (kg)	Frequency (Hz)	Motor power (KW)
KV/90	6	20	50Hz	0.2
	9		50Hz	0.2
	12		50Hz	0.2
	15		50Hz	0.2
	18		50Hz	0.2
KV/180	6	20	50Hz	0.2
	9		50Hz	0.2
	12		50Hz	0.2
	15		50Hz	0.2
	18		50Hz	0.2
CV/90	6	90	50Hz	0.2
	9		50Hz	0.2
	12		50Hz	0.2
	15		50Hz	0.2
	18		50Hz	0.2
CV/180	6	60	50Hz	0.2
	9		50Hz	0.2
	12		50Hz	0.2
	15		50Hz	0.2
	18		50Hz	0.2
QV	6	Load limit per unit length: 1 kg/cm	50Hz	0.2
	9		50Hz	0.2
	12		50Hz	0.2
	15		50Hz	0.25
	18		50Hz	0.25

08

Lifter

The LP lifter transports single or multiple conveyor trays vertically between the multi-layer conveyor

LP/B—Synchronous belt lifter is driven by screw and server motor

which is suitable for transporting between multi-layer conveyor and a short cycle time situation

LP/P—Rodless cylinder lifter is driven by rodless cylinder

which is only suitable for transporting between two layer conveyor, cost-effective, and a short cycle time situation

LP/S—Screw lifter is driven by screw and server motor

which is suitable for transporting between multi-layer conveyor and a short cycle time situation

LP/B Synchronous belt lifter



Delivery note

Recommended accessories

Foundation Bracket

Stop gate

server motor

Delivery involved

Complete synchronous belt lifter

Optical Switch: EE-SX672A

Counter-optical: CX-411

Condition on delivery

Fully assembled

Suitable for transporting between multi-layer conveyors

The lifter can transfer single or multiple or multiple pallets at a time, and allow accumulation operation to meet the requirements of cycle time

Max. Load: 30KG

Lifting speed: $\leq 500\text{mm/s}$

The stroke can be adjusted within a certain range.

Special models on request

Dimensions

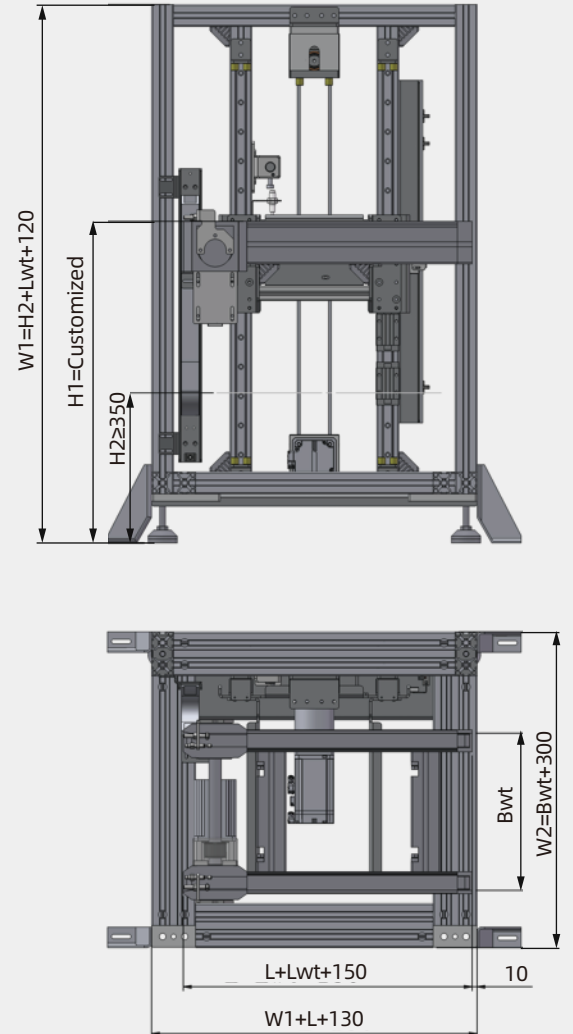

$W1 = H2 + Lwt + 120$
 $H1 = \text{Customized}$
 $H2 \geq 350$

Bwt
 $W2 = Bwt + 300$

$L + Lwt + 150$
 10
 $W1 + L + 130$

步进电机参数说明

电机力矩: 9.4N·m
 驱动器: SRX08-V (不在供货范围)

AM34HD2403
 Subdivide: 200002 steps/revolution
 Current: 7.0A (peak value)

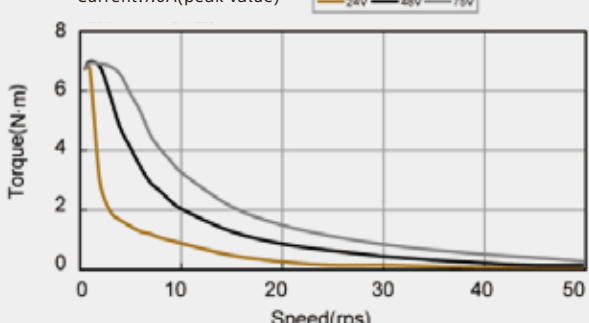

▲ 步进电机速度力矩曲线



The above specifications are suitable for single pallet lifting
 Special customized pallets or multi-pallet, please inquire

Ordering information

Track width(mm)*	Bwt	160,240,320,400,480(160≤Bwt≤480)(Special width on request;)
Conveyor length(mm)	L	L=Lwt+150
Max. Load(KG)		30
Lift position		Any position
Lifting speed(s/mm)	V	≤500
Nominal speed(m/min)*		0,6,9,12,15,18(V=0, no motor is configured,and other speeds can be customized;)
Conveyor body motor type		Two phase stepper motors
Motor mounting way	MA	L,R,M(MA=M,only applicable to occasion with Bwt≥240)
Voltage*	U	server motor: 220V stepper motor: 24V (For other power supply voltage requirements,please contact us for details;)
Frequency*	f	50Hz (a.For other power frequency requirement,please inquire; b.Can be adjusted by frequency converter;)
Motor power connection	AT	Terminal box(The Terminal box and outlet are shown in the figure, Please call for other requirements.)

LP/P Rodless cylinder lifter

Rodless cylinder lifter is driven by rodless cylinder, which is only suitable for transporting between two layer conveyor, cost-effective, and a short cycle time situation



Delivery note

Recommended accessories

Foundation Bracket
Stop gate
server motor

Delivery involved

Complete rodless cylinder lifter
Magnetic Switch: D-M9B
Counter-optical: CX-411
Speed control valve ($\phi 10$)

Condition on delivery

Fully assembled

- ▶ Only suitable for transporting between two layer conveyors
- ▶ The lifter can transfer single or multiple or multiple pallets at a time, and allow accumulation operation to meet the requirements of cycle time
- ▶ **Max. Load:** 30KG
- ▶ **Lifting speed:** $\leq 300\text{mm/s}$
- ▶ Stroke is customized
- ▶ Special models on request

Dimensions

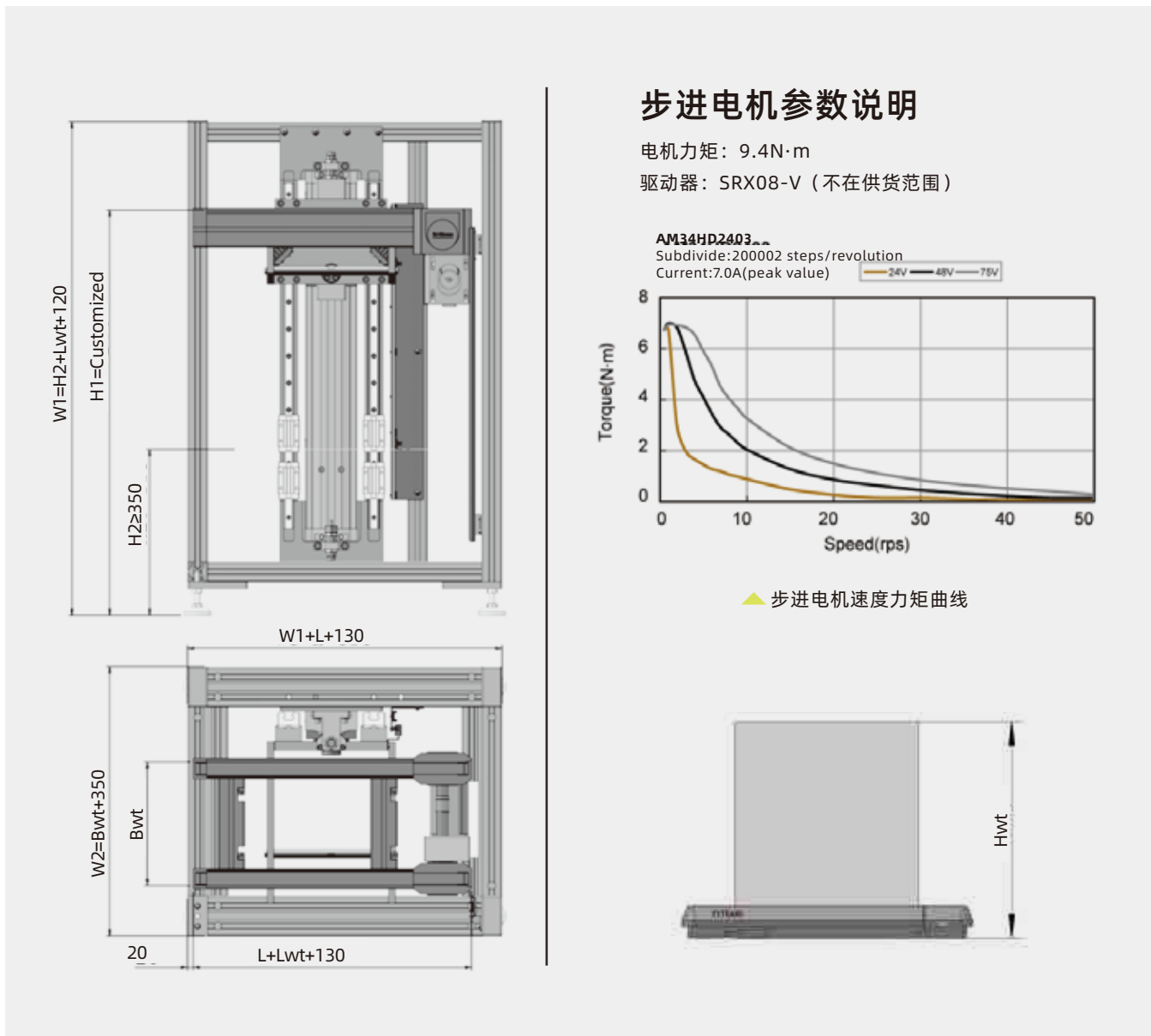

The above specifications are suitable for single pallet lifting
 Special customized pallets or multi-pallet, please inquire

Ordering information

Track width in direction of transport(mm)*	Bwt	160,240,320,400,480(160≤Bwt≤480)
Length in direction of transport(mm)	L	L=Lwt+160
Max. Load(KG)		30
Lift position		2
Lifting speed(s/mm)	V	≤300
Cylinder bore(mm)		50
Nominal speed(m/min)*		0,6,9,12,15,18
Conveyor body motor type		Two phase stepper motors
Motor mounting way	MA	L,R,M
Voltage*	U	server motor: 220V stepper motor: 24V
Frequency*	f	50Hz
Motor power connection	AT	Terminal box
Track width in direction of transport		Special width on request;
Nominal speed		When V=0,no motor is configured,and other speeds can be customized;
Motor mounting way		MA=M,only applicable to occasion with Bwt≥240
Voltage		For other power supply voltage requirements,please contact us for details;
Frequency		a.For other power frequency requirement,please inquire; b.Can be adjusted by frequency converter;
Motor connection		The Terminal box and outlet are shown in the figure, Please call for other requirements.

LP/S Screw lifter

Screw lifter is driven by screw and server motor, which is suitable for transporting between multi-layer conveyor and a short cycle time situation

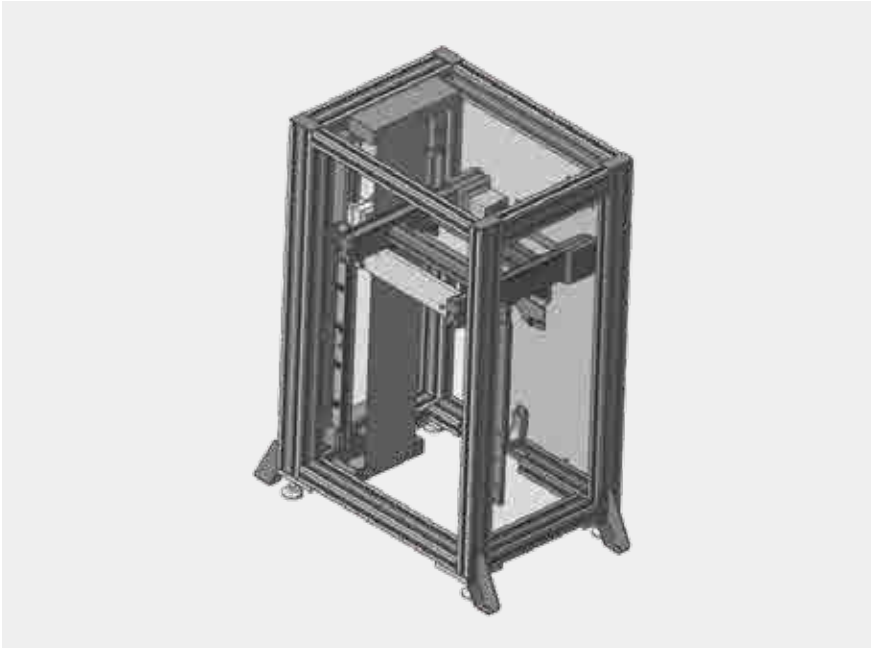

Delivery note

Recommended accessories

Foundation Bracket

Stop gate

server motor

Delivery involved

Complete Screw lifter

Slot Photoelectric: EE-SX672A

Counter-optical: CX-411

Condition on delivery

Fully assembled

- ▶ Suitable for transporting between multi-layer conveyors
- ▶ The lifter can transfer single or multiple or multiple pallets at a time, and allow accumulation
- ▶ operation to meet the requirements of cycle time
- ▶ **Max. Load:** 30KG
- ▶ **Lifting speed:** $\leq 500\text{mm/s}$
- ▶ The stroke can be adjusted within a certain range.
Special models on request

Ordering information

Track width in direction of transport(mm)*	Bwt	160,240,320,400,480
Length in direction of transport(mm)	L	L=Lwt+160
Max. Load(KG)		30
Lift position		Any position
Lifting speed(mm/s)	V	≤500
Cylinder bore(mm)		10
Nominal speed(m/min)*		0,6,9,12,15,18(When V=0,no motor is configured, and other speeds can be customized;)
Conveyor body motor type		Two phase stepper motors
Motor mounting way	MA	L,R,M
Voltage*	U	server motor: 220V stepper motor: 24V
Frequency*	F	50Hz
Motor power connection	AT	Terminal box
Track width in direction of transport		Special width on request;
Nominal speed		When V=0,no motor is configured,and other speeds can be customized;
Motor mounting way		MA=M,only applicable to occasion with Bwt≥240
Voltage		For other power supply voltage requirements,please contact us for details;
Frequency		a.For other power frequency requirement,please inquire; b.Can be adjusted by frequency converter;
Motor connection		The Terminal box and outlet are shown in the figure, Please call for other requirements.

Dimensions

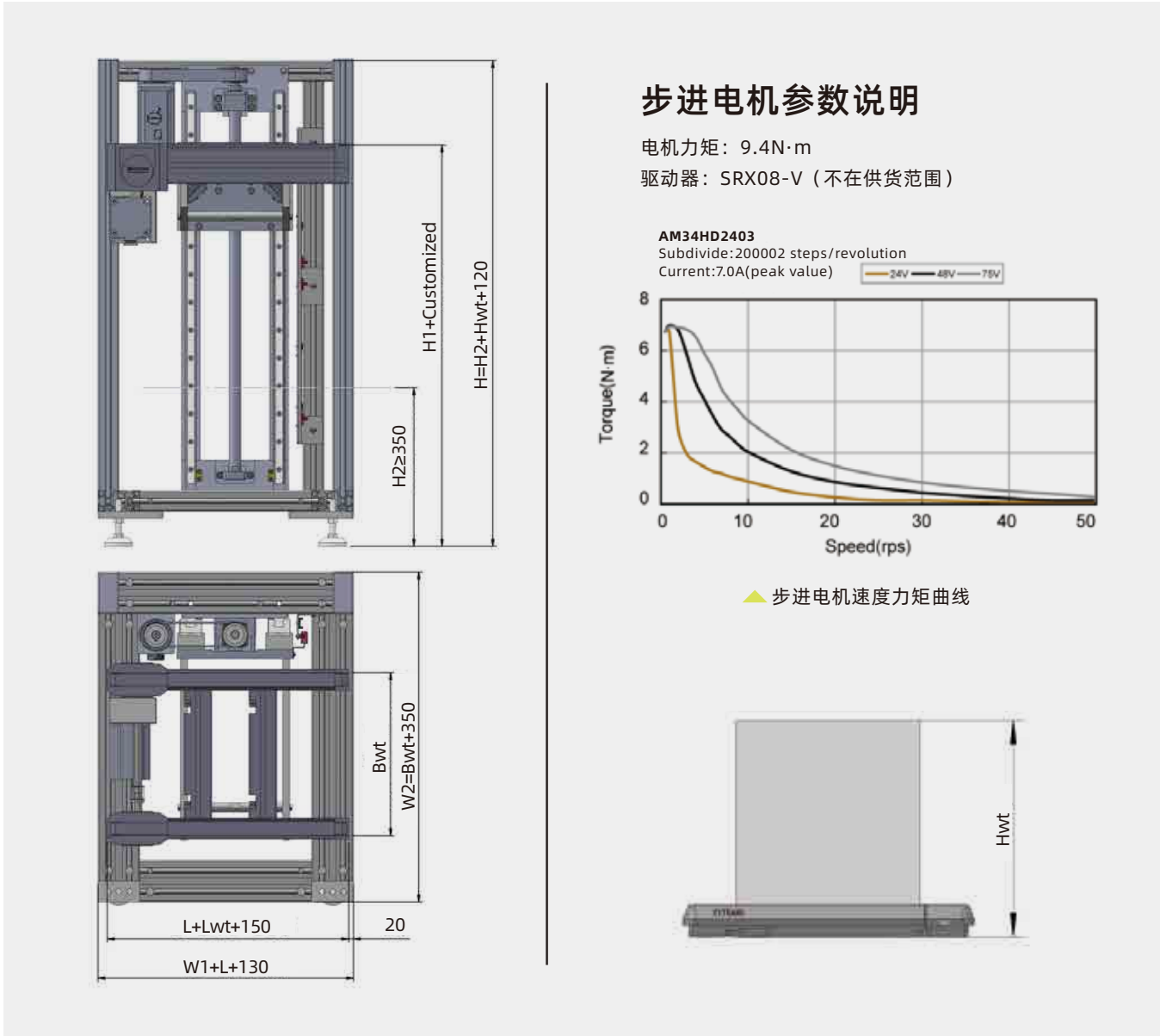

The above specifications are suitable for single pallet lifting
 Special customized pallets or multi-pallet, please inquire

Customized model description

LP/S	Lifter type: LP/S LP/P LP/B
<input type="checkbox"/>	Conveyor type: BC2 / PC2 / FC2 / AC2
B <input type="checkbox"/>	Pallet width: B160 / B240 / B320 / B400 / B480 /Customized
L <input type="checkbox"/>	Pallet length: L160 / L240 / L320 / L400 / L480 /Customized
V <input type="checkbox"/>	Nominal speed: 0 ₁) / V6 / V9 /V12 / V15 / V18 / Customized
MA	Motor mounting way: L, R, M
<input type="checkbox"/> - <input type="checkbox"/>	Stroke range
SP	Special requirement: <ul style="list-style-type: none"> a.Special voltage requirement b.Special Frequency requiremen c.Special Terminal box and outlet requirement d.Special motor connection requirement e.Special motor mounting requirement <p style="margin-left: 20px;">1)When speed is 0,means no drive motor</p> <p style="margin-left: 20px;">The lifting speed can be customized,up to 1000m/s</p>

Customized model example

LP/S-AC2-B320-L320-V12-M-500-900

Lifter type:LP/S **Conveyor type:**AC2 **Pallet width:**Bwt=320 **Pallet length:** Lwt=320 **Conveyor nominal speed:** 12 m/min

Stroke range: 500-900 **Motor mounting way:** MA=M **Special requirement:** None

09

Transportation control

The stop gate is used to control pallets on the conveyor system including pallet blocking, separation sensing, and control function processes, etc.

SG stop gate—Pneumatic stop gate for pallet stopping

SG/D-60—Pneumatic dampened stop gate

SG/D-150—Pneumatic dampened stop gate

Pneumatic dampened stop gate is used to overcome the bouncing of pallets caused by hard stops.

SG/V—Single acting buffer

SG/V—Double acting buffer

The buffer is used when the pallet is moved out or into the main line

The buffer is used to reduce the impact

SG/L—Cross sliding stop

SG/D—Cross sliding stop(Reversible)

Sliding stop is used to connect more than two longitudinal conveyor segments and in transverse conveyor segments where additional stopping devices are required.

SG/R—Return stop

Return stop is used to overcome the bouncing of pallets caused by the blocking of no pneumatic dampened stop gate.

ZJ/S—Switch bracket/side

For fixing proximity switches on the outer side of the conveyor profile

ZJ/U—Switch bracket/bottom

Used to fix the access switch mounted on the inner side of the conveyor profile



Depending on the situation, you can choose either internal stops or external stops, with the internal stops being more space-efficient.

SG Stop gate

Stopping of one or more stacked pallets of workpieces in a specified position

When the pressure is released, the spring closes the stop gate, thus stopping the workpiece pallet.

Mounted directly on the conveyor section within the track

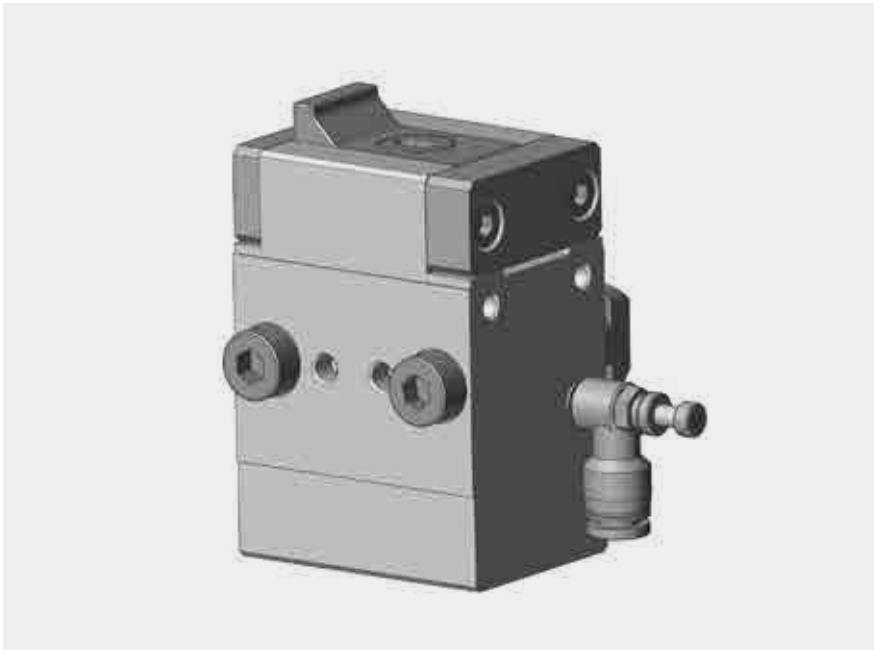

Delivery note

Delivery involved

SGStop gate

L-type threaded tee ($\phi 6$)

Recommended accessories

Solenoid valve

Sensor

Switch bracket

Condition on delivery

Fully assembled

- ▶ Pneumatic stop gate
- ▶ No scratches on the surface of the workpiece pallet during the opening action.
- ▶ Reverse operation is not allowed
- ▶ Can be combined with WA2, WE2
- ▶ **Max. stopping capacity:** 200KG

Ordering information Dimensions

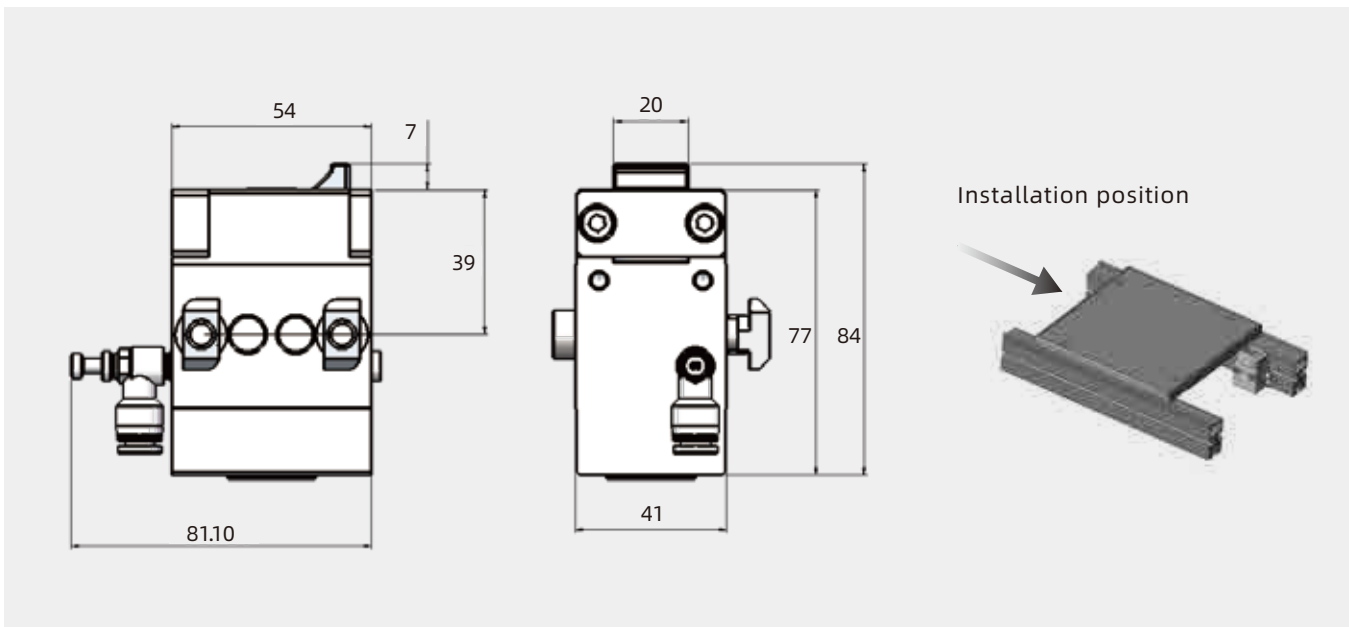

Product Description	Stop gate
Ordering Model	SG.PN.0102

Stop gate load vs. speed graph:

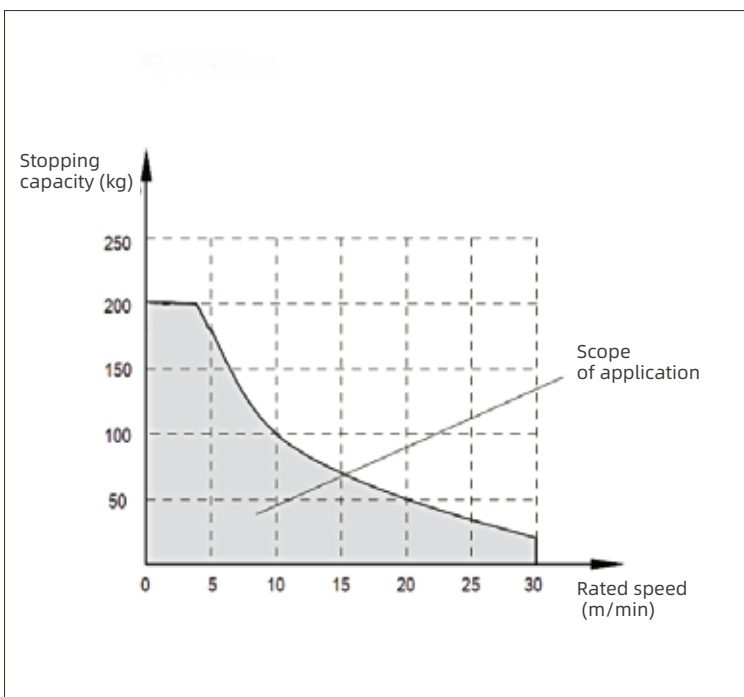

Schematic:

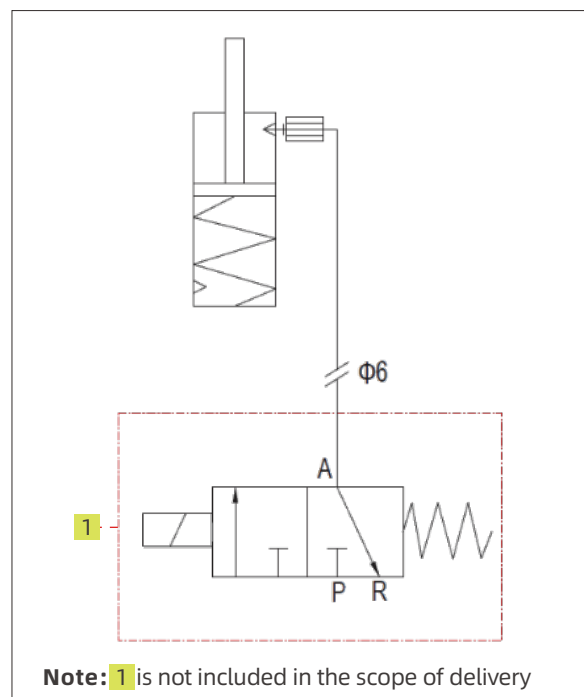

SG/D-60 Pneumatic dampened stop gate

Buffer stops the first workpiece pallet

The stop gate stops one or more stacked pallets in a defined position.

When the pressure is released, the spring closes the stop gate, thus stopping the pallet.



Delivery note

Delivery involved

Stop gate
L-type threaded tee ($\phi 6$)

Recommended accessories

Solenoid valve
Sensor
Switch bracket

Condition on delivery

Fully assembled

- ▶ Pneumatic stop gate
- ▶ Best vibration damping for workpiece pallets weighing up to 60kg.
- ▶ Shock absorption is infinitely adjustable
- ▶ Can be combined with WA2, WE2

Ordering information Dimensions

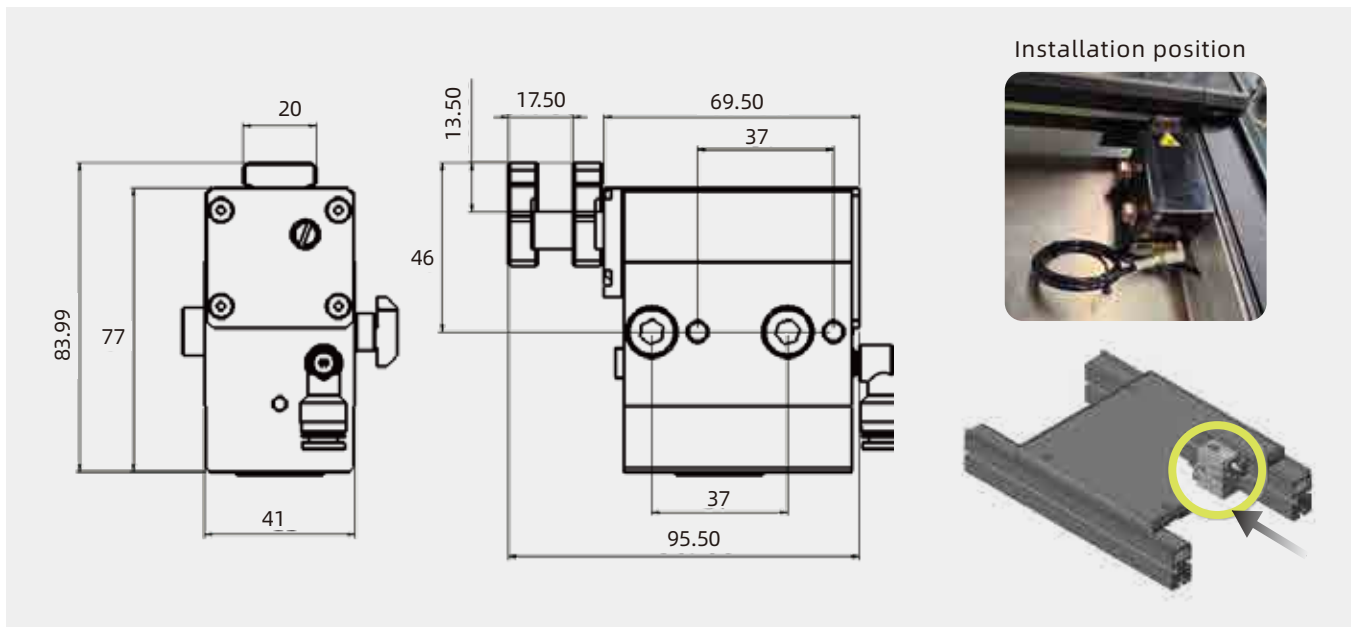

Product Description	Pneumatic dampened stop gate
Ordering Model	SG/D.PN.0201

Stop gate load vs. speed graph:

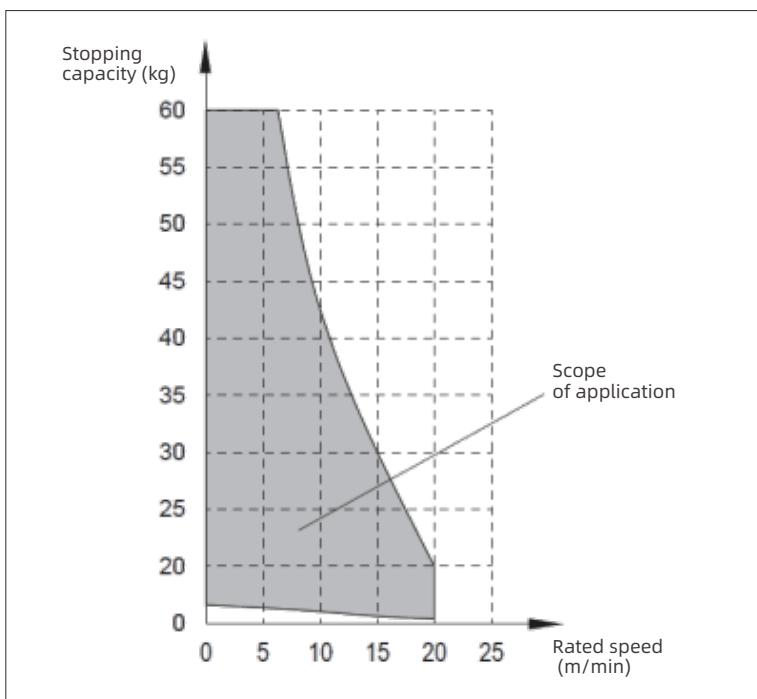

Schematic:

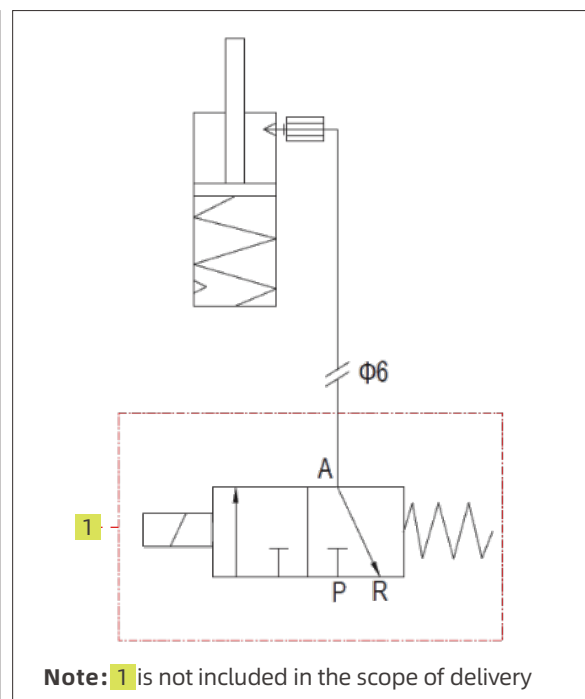

SG/D-150 Pneumatic dampened stop gate

Buffer stops the first workpiece pallet

The stop gate stops one or more stacked pallets in a defined position.

When the pressure is released, the spring closes the stop gate, thus stopping the pallet.

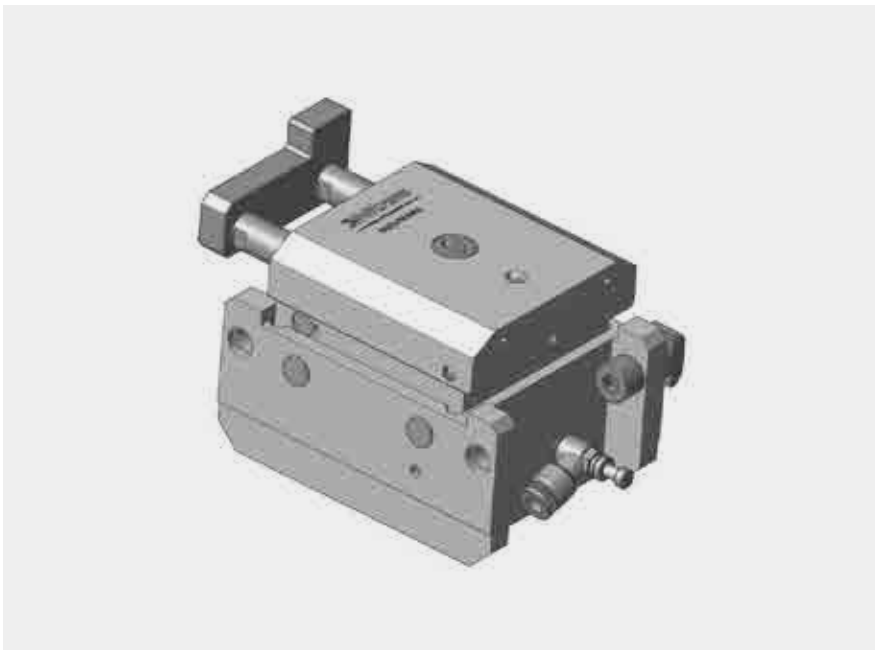

Delivery note

Delivery involved

Stop gate

L-type threaded tee ($\phi 6$)

Recommended accessories

Solenoid valve

Sensor

Switch bracket

Condition on delivery

Fully assembled

- ▶ Pneumatic stop gate
- ▶ Best vibration damping for workpiece pallets weighing up to 150kg.
- ▶ Shock absorption is infinitely adjustable
- ▶ Can be combined with WA2, WE2

Ordering information Dimensions

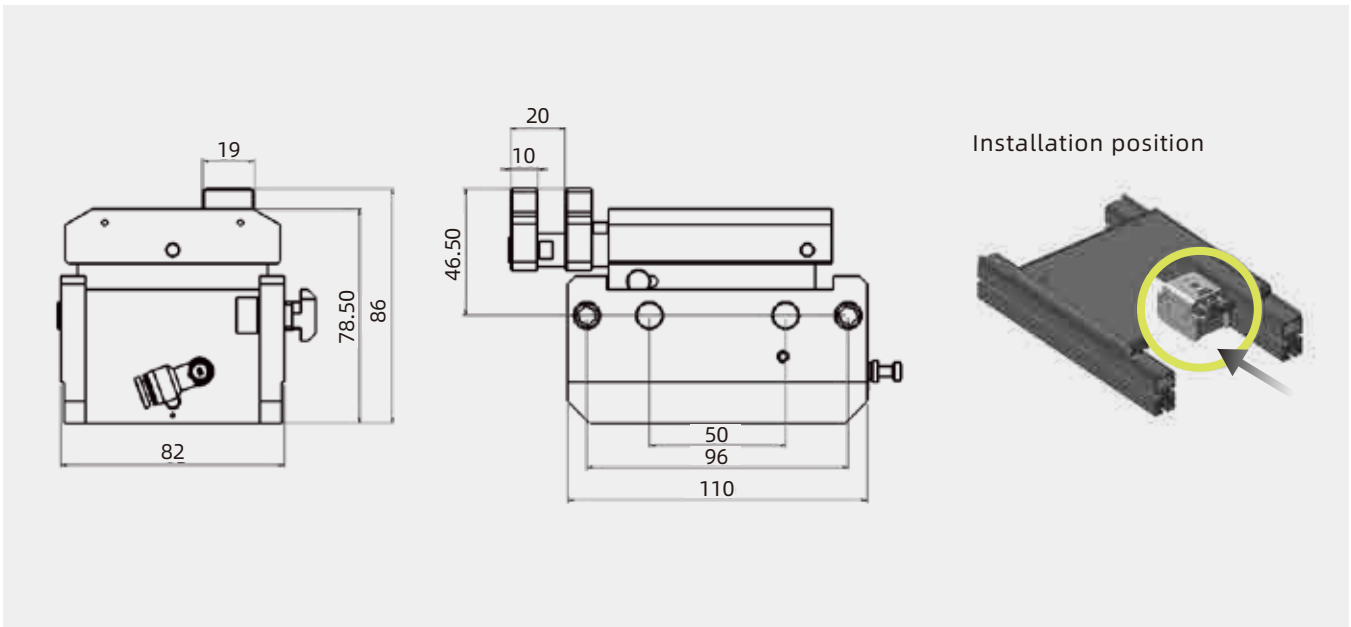

Product Description	Pneumatic dampened stop gate
Ordering Model	SG/D.PN.04011

Stop gate load vs. speed graph:

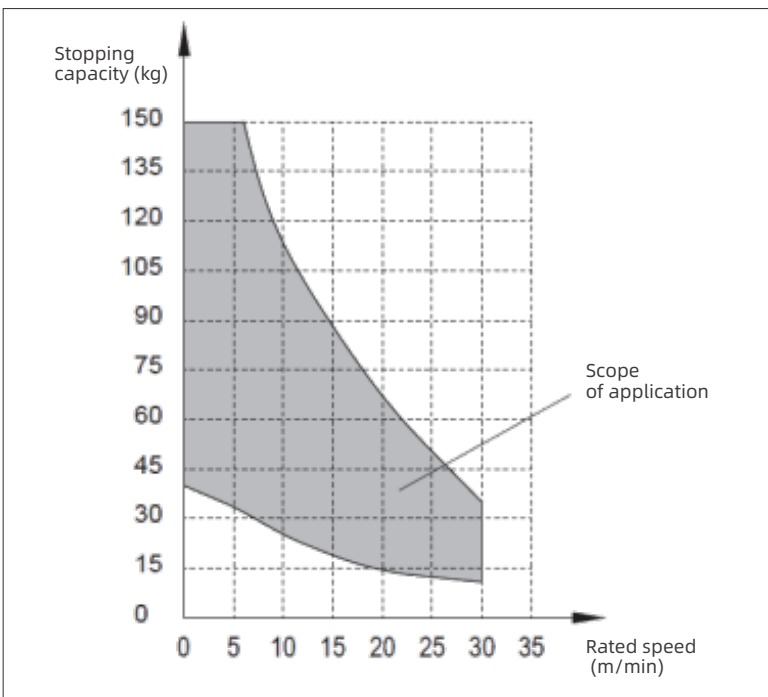

Schematic:

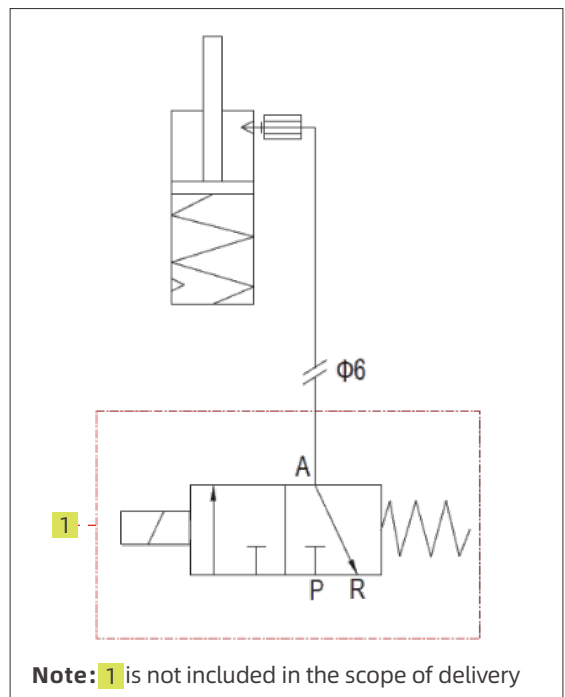

SG/V Single acting buffer

The buffer is used to reduce the impact of the pallet when it is moved out of or into the mains.

When the buffer opens and the pallet is released into the buffer, the buffer is pneumatically reset at the same time

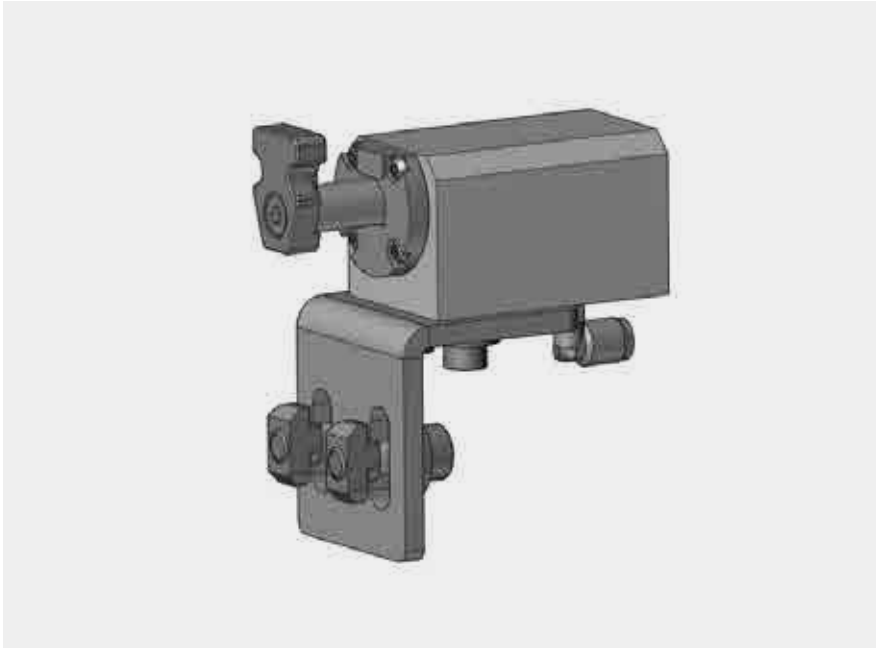

Delivery note

Delivery involved

Stop gate
L-type threaded tee ($\phi 6$)

Recommended accessories

Solenoid valve
Sensor
Switch bracket

Condition on delivery

Fully assembled

- ▶ No reverse operation allowed, mounted directly on the conveyor line body
- ▶ Operating noise less than 60dB
- ▶ Cushioning force can be adjusted by the adjusting screw at the back of the cushion.
- ▶ Can be combined with WA2, WE2

Ordering information Dimensions

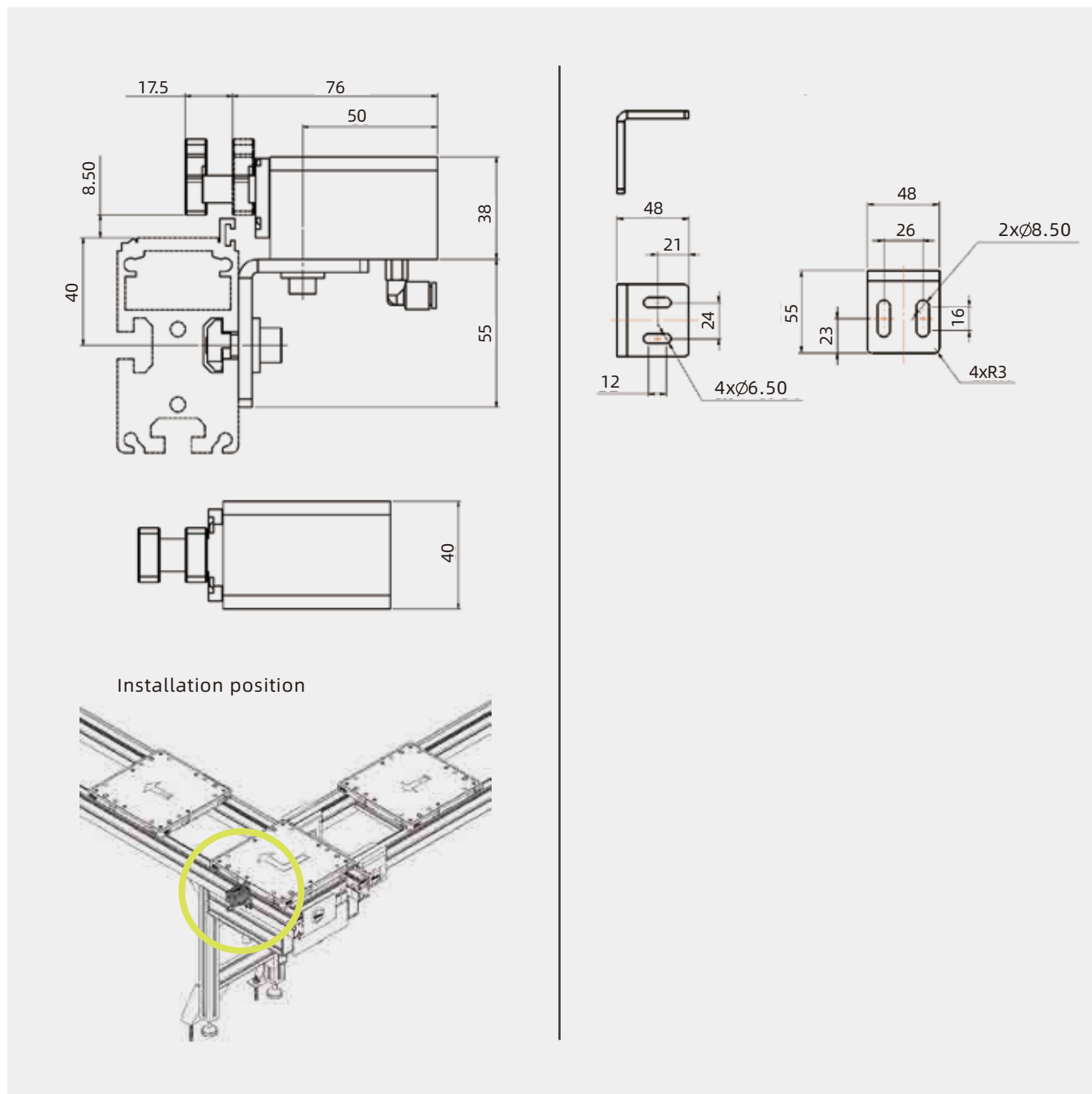

产品描述	单作用缓冲器
订购型号	SG/V.PN.0501
工件与托盘最大总质量 (KG)	60
工件与托盘最小总质量 (KG)	1

Stop gate load vs. speed graph:

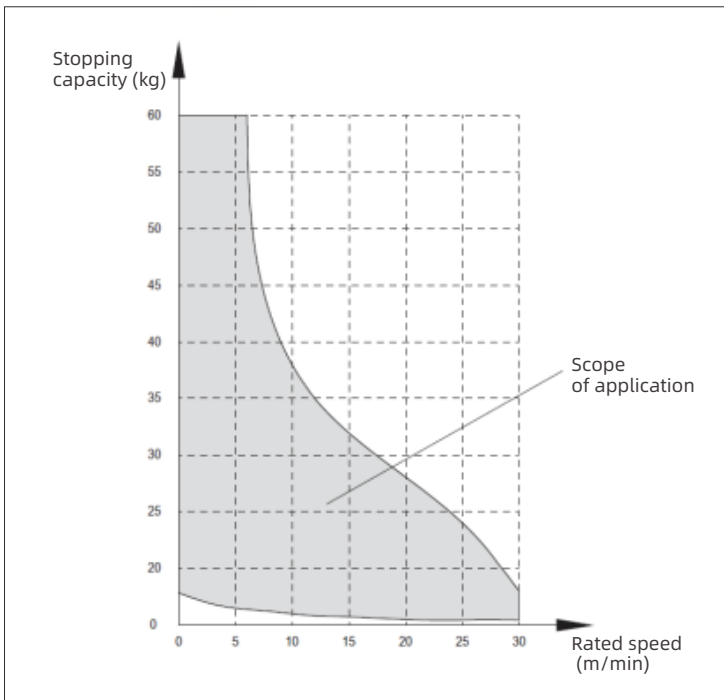

Schematic:

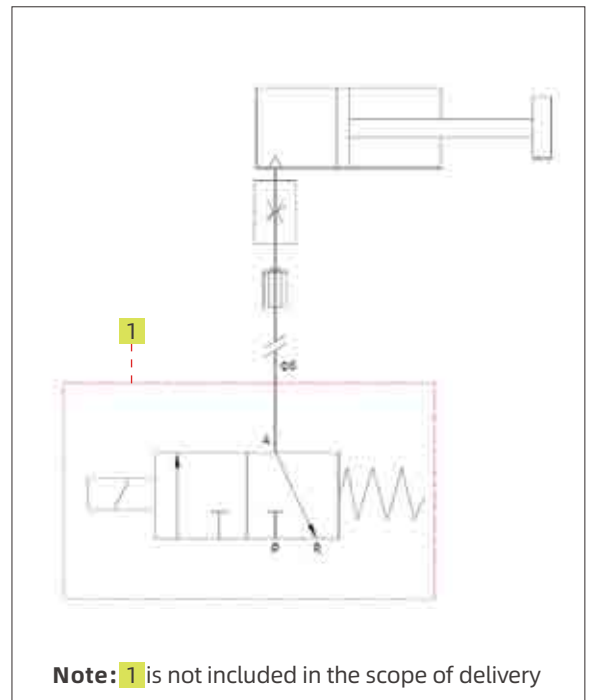

SG/V Double acting buffer

The buffer is used to reduce the impact of the pallet when it is moved out of or into the mains.

When the buffer opens and the pallet is released into the buffer, the buffer is pneumatically reset at the same time

When the pallet is conveyed along the main line body, the buffer stopper is retracted and the pallet is normally retracted.

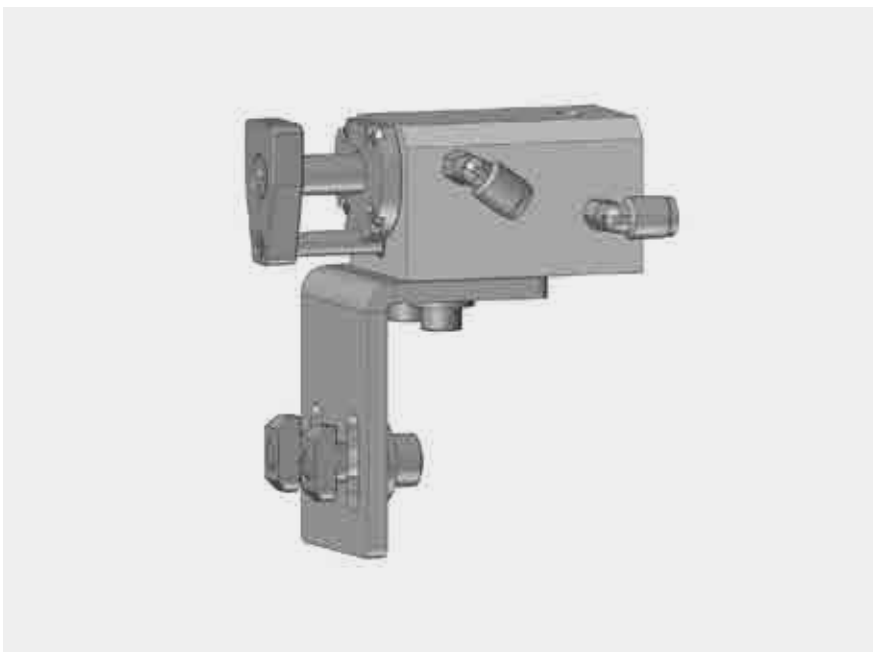

Delivery note

Delivery involved

Stop gate
L-type threaded tee ($\phi 6$)
Mounting Bracket

Recommended accessories

Solenoid valve
Sensor
Switch bracket

Condition on delivery

Fully assembled

- ▶ No reverse operation allowed, mounted directly on the conveyor line body
- ▶ Operating noise less than 60dB
- ▶ Cushioning force can be adjusted by the adjusting screw at the back of the cushion.
- ▶ Can be combined with WA2, WE2

Ordering information Dimensions

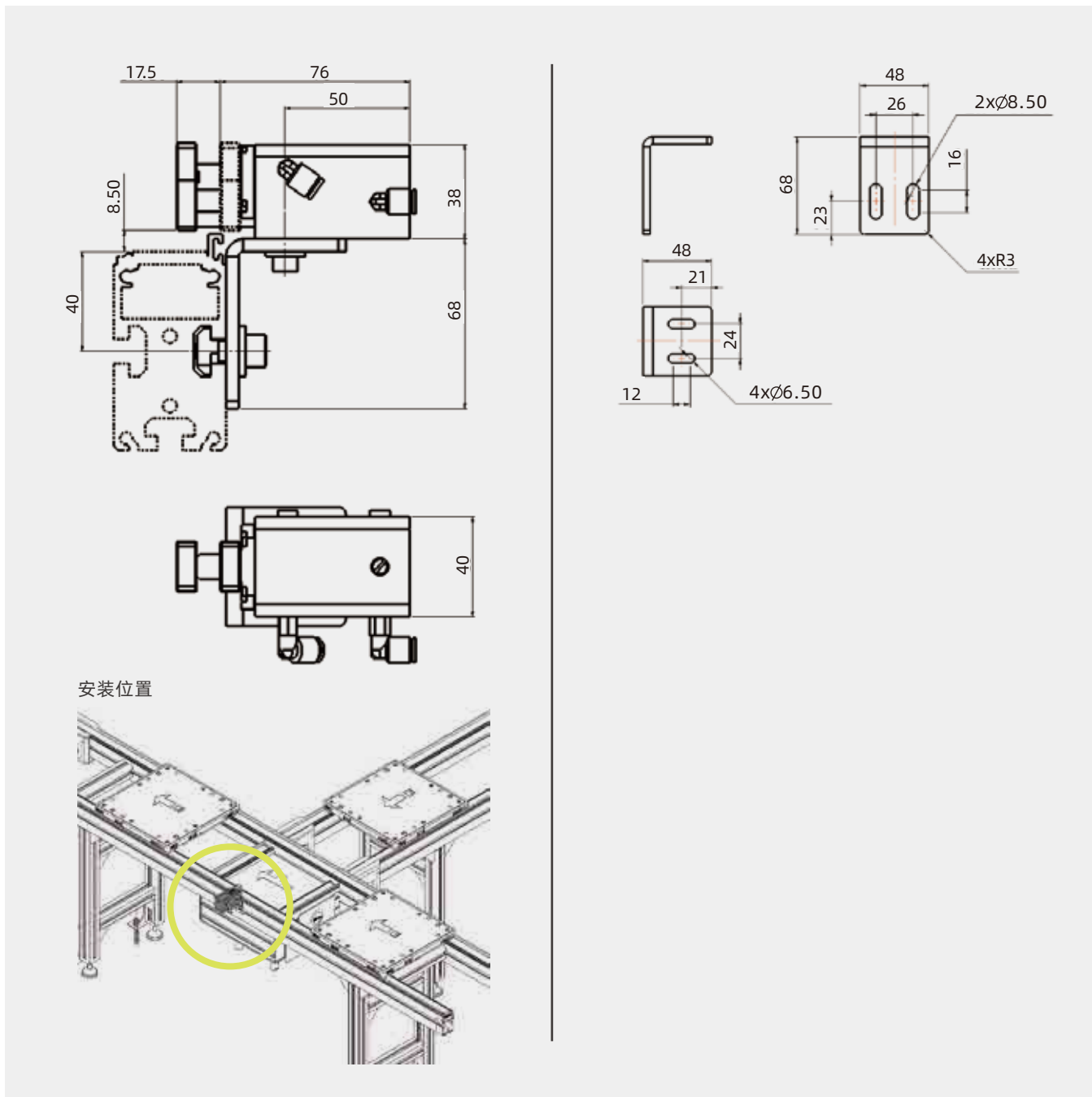

产品描述	双作用缓冲器
订购型号	SG/V.PN.0502
工件与托盘最大总质量 (KG)	60
工件与托盘最小总质量 (KG)	5

Stop gate load vs. speed graph:

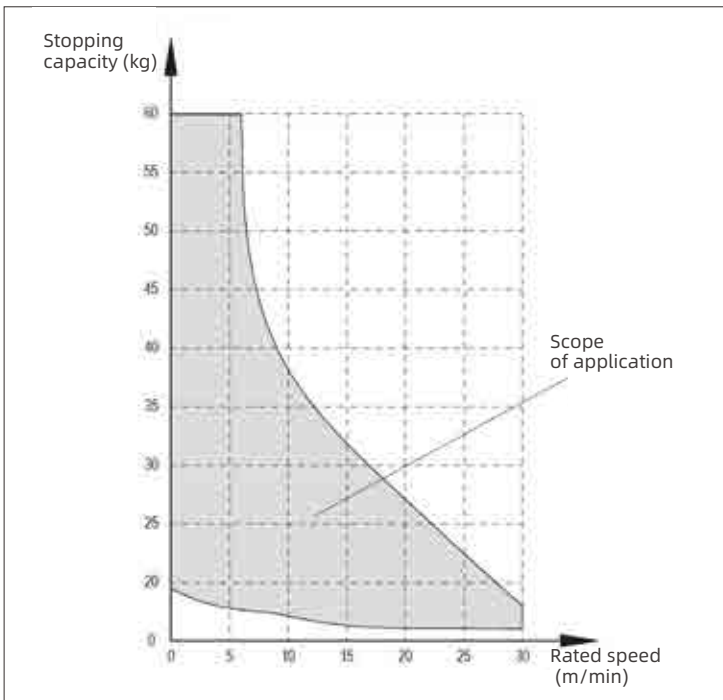

Schematic:

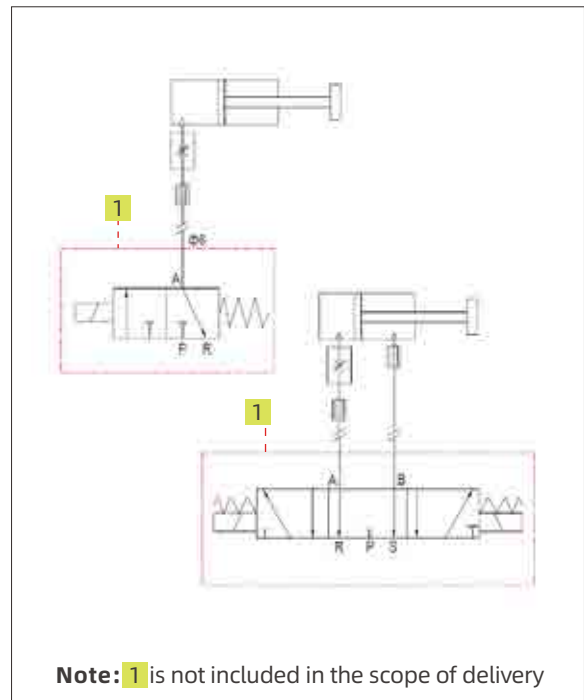

Note: 1 is not included in the scope of delivery

SG/L Cross sliding stop

Sliding stops are used in connecting more than two longitudinal conveyor segments and in transverse conveyor segments where additional stops are required.

The transverse conveyor unit moves the pallet of workpieces into the longitudinal conveyor section with the action of the sliding stops.

When there is no pressure in the system, the pneumatically extendable sliding stopper is lowered to the lower position

Directly mounted on the trough of the conveyor section



Delivery note

Delivery involved

Complete Cross sliding stop
L-type threaded tee ($\phi 6$)

Recommended accessories

Solenoid valve

Condition on delivery

Fully assembled

- ▶ Slide stopper to lower pneumatically
- ▶ Reverse operation is not allowed
- ▶ Suitable for a wide range of wire forms
- ▶ Can be combined with WA2, WE2

Ordering information Dimensions

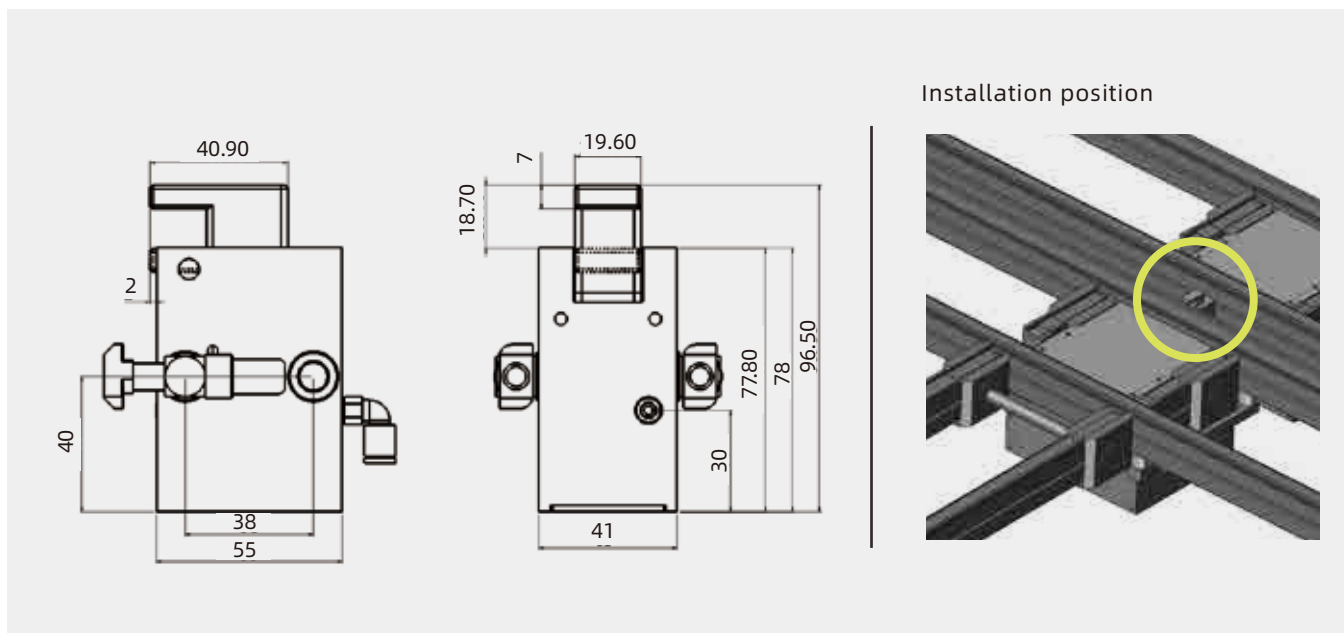

Product Description	Ordering Model
Cross sliding stop	SG/L.PN.0701

Total mass of workpiece pallet (kg)	Rated speed (m/min)
50	6
50	9
35	12
25	15
20	18

Schematic:

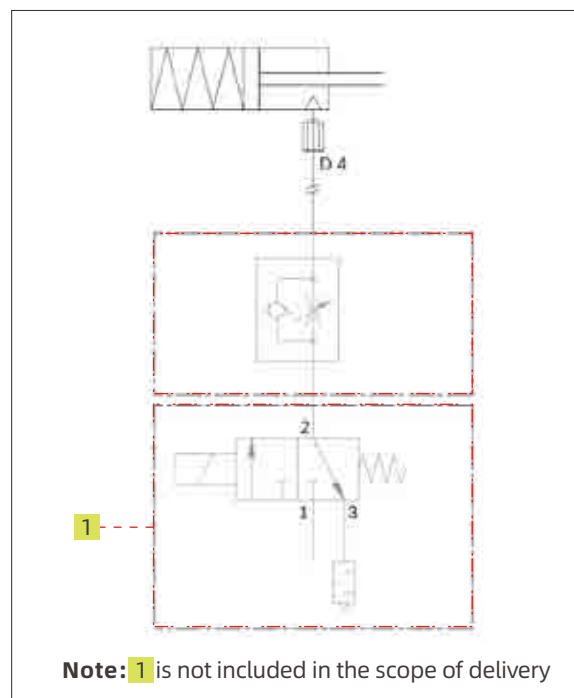

SG/D Cross sliding stop-reversible

Sliding stops are used in connecting more than two longitudinal conveyor segments and in transverse conveyor segments where additional stops are required.

The transverse conveyor unit moves the pallet of workpieces into the longitudinal conveyor section with the action of the sliding stops.

When there is no pressure in the system, the pneumatically extendable sliding stopper is lowered to the lower position

The upper position of the sliding block can be sensed by a sensor.

Directly mounted on the trough of the conveyor section

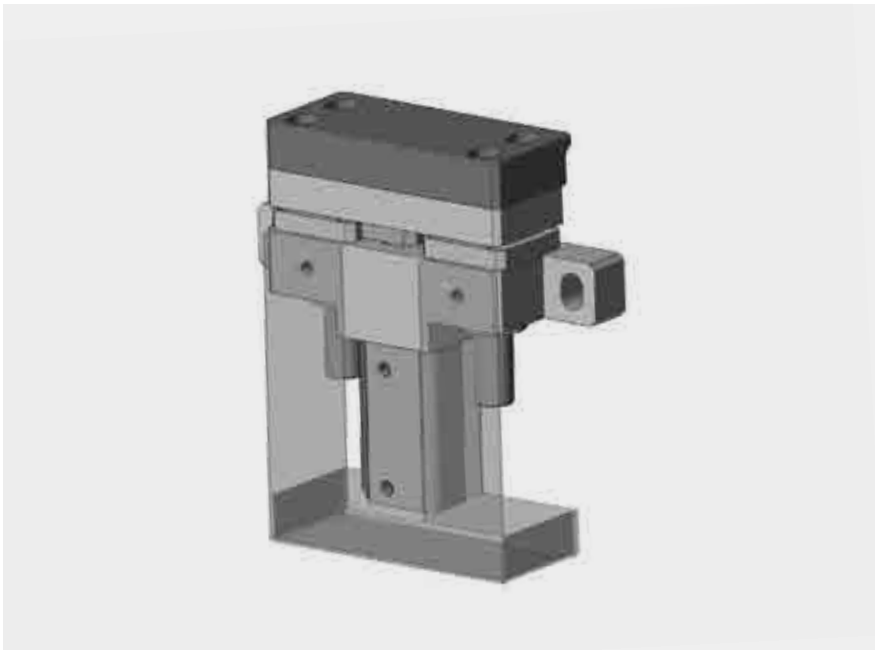

Delivery note

Delivery involved

Complete Cross sliding stop-reversible

L-type threaded tee ($\phi 6$)

Magnetic Switch: D-M9B

Recommended accessories

Solenoid valve

Condition on delivery

Fully assembled

- ▶ Slide stopper to lower pneumatically
- ▶ Allow reverse operation
- ▶ Suitable for a wide range of wire forms
- ▶ Can be combined with WA2, WE2

Ordering information Dimensions

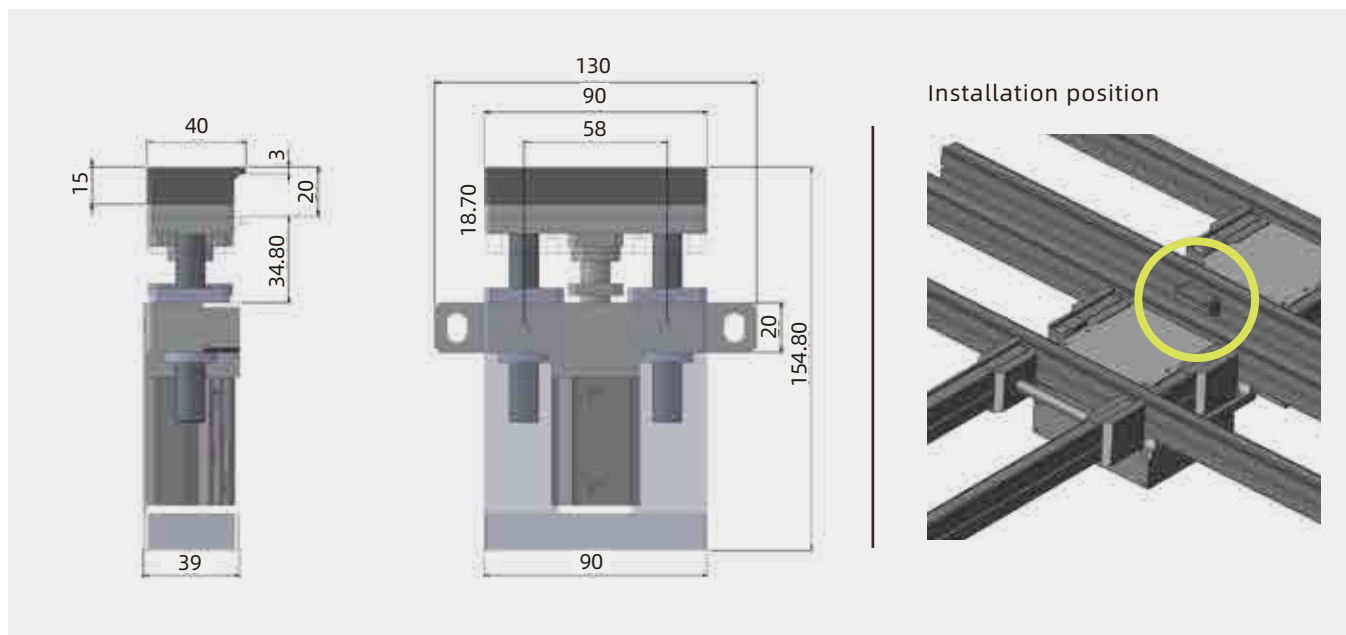

Product Description	Ordering Model
Cross sliding stop-reversible	SG/L.PN.0702

Total mass of workpiece pallet (kg)	Rated speed (m/min)
50	6
50	9
35	12
25	15
20	18

Schematic:

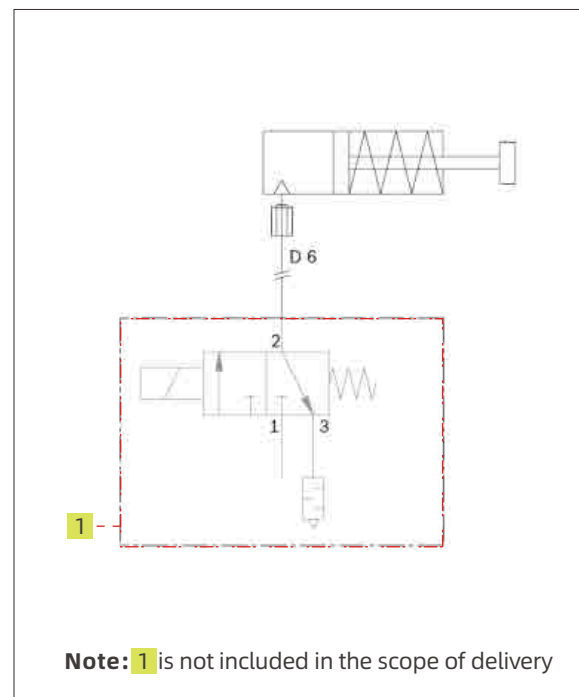

SG/R Return stop

Return stop is used to overcome the bouncing of pallets caused by the blocking of no pneumatic dampened stop gate.

Preventing pallet reversal

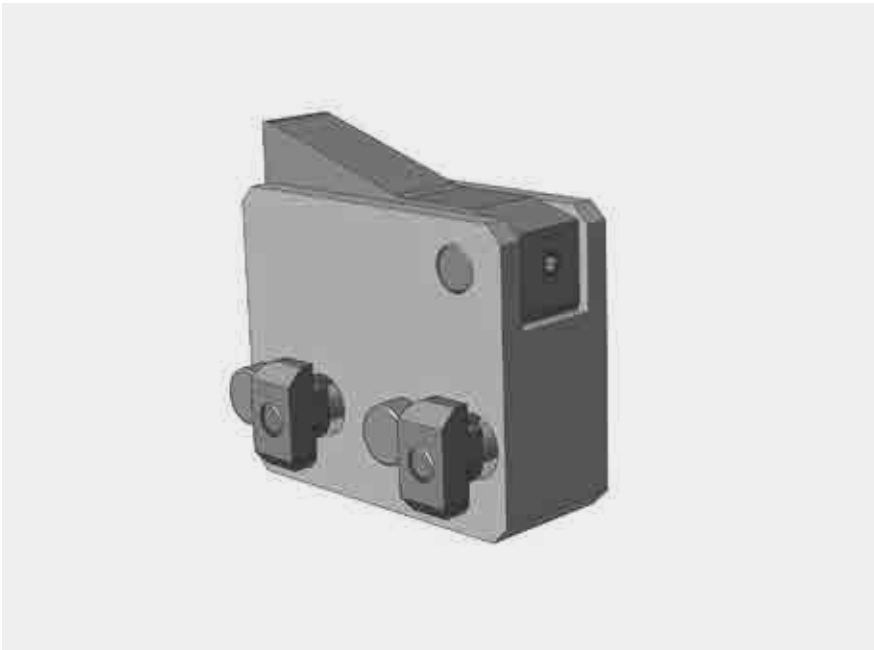

Delivery note

Delivery involved

Complete return stop

Recommended accessories

Stop gate

Condition on delivery

Fully assembled

- ▶ Can be used on the left or right side
- ▶ For pallets with rebound
- ▶ Can be used for unidirectional conveying, does not allow reverse operation
- ▶ Can be combined with WA2, WE2

Ordering information Dimensions

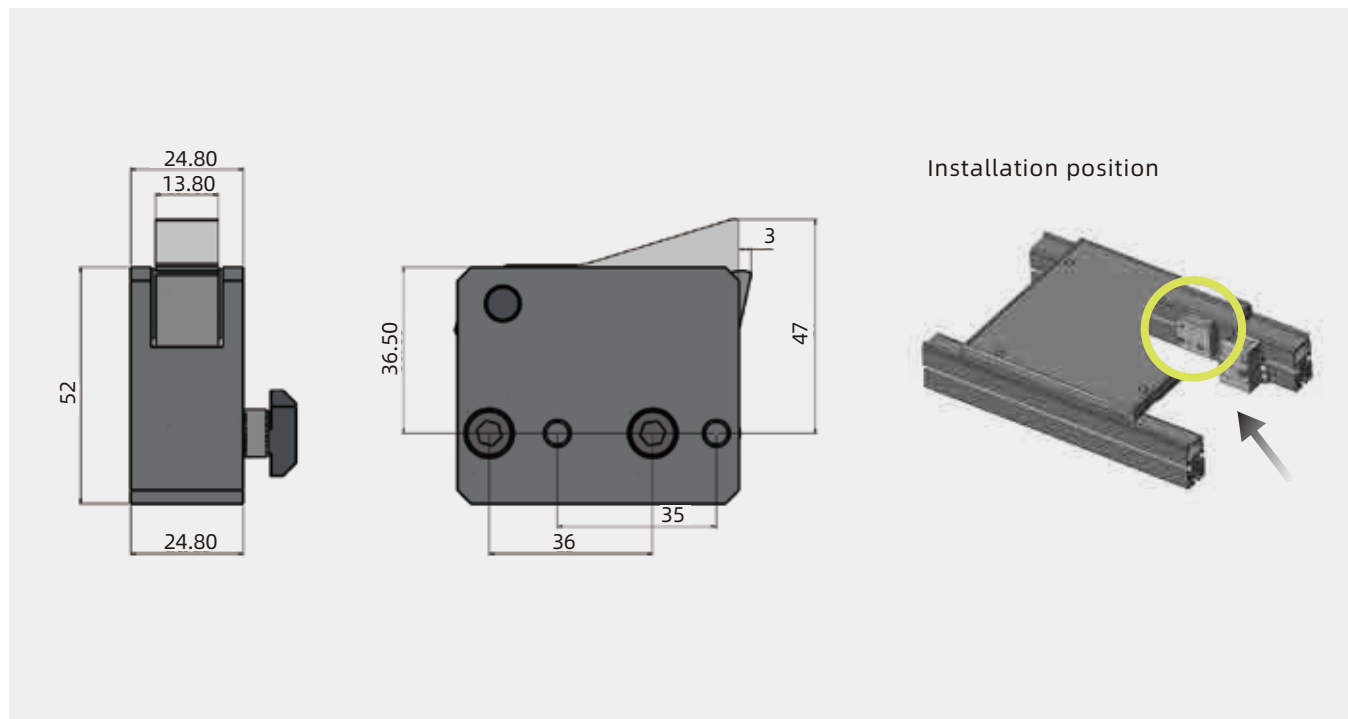

Product Description	Stop gate
Ordering Model	SG/R.PN.0301

ZJ/S Switch bracket/side

Switch bracket for fixing the workpiece tray position Side sensing application sensor M12x1



Delivery note

Delivery involved

Switch bracket

Condition on delivery

Not assembled

- ▶ For fixing sensors
- ▶ Side sensing for positions of workpieces pallet
- ▶ Mounted on slotted holes on the side of the conveyor section
- ▶ Can be combined with WA2, WE2

Ordering information Dimensions

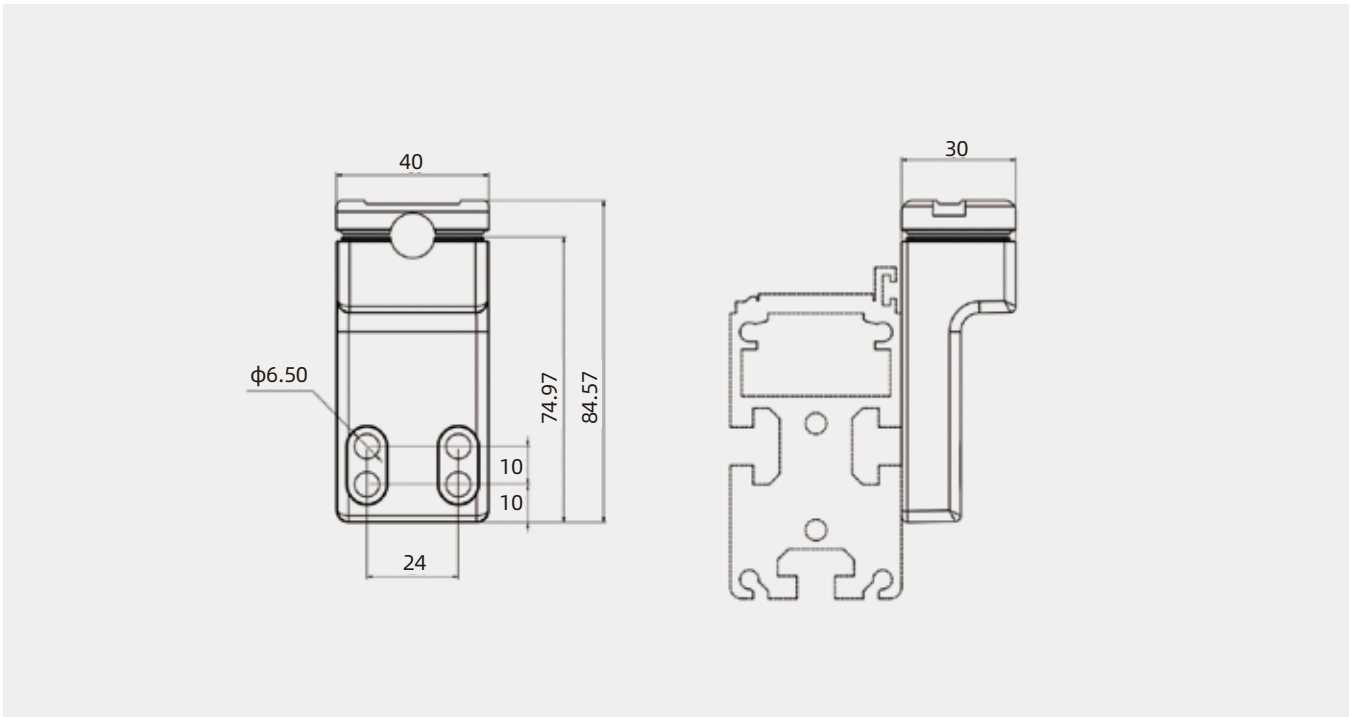

Product Description	Switch bracket
Ordering Model	ZJ/S

ZJ/U Switch bracket/bottom

Switch bracket for fixing the workpiece pallet position Bottom sensing application sensor M12x1

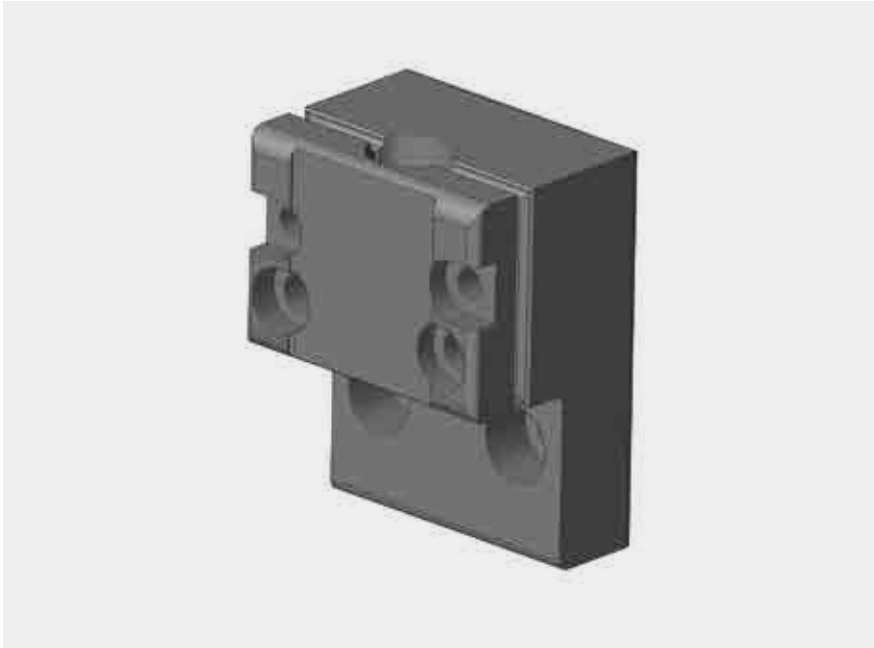

Delivery note

Delivery involved

Switch bracket

Condition on delivery

Not assembled

- ▶ For fixing sensors
- ▶ Bottom sensing for workpiece pallet positions
- ▶ Mounted on slotted holes on the side of the conveyor section
- ▶ Can be combined with WA2, WE2

Ordering information Dimensions

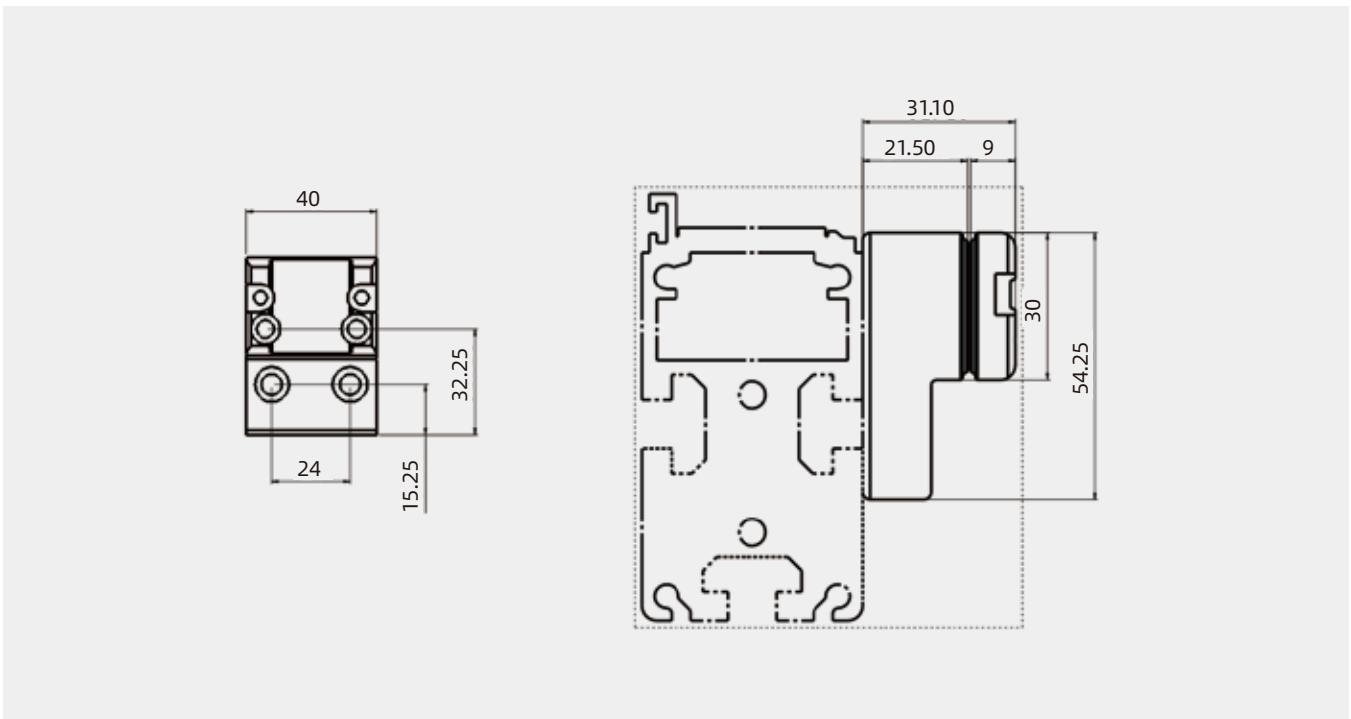

Product Description	Switch bracket
Ordering Model	ZJ/U

10

Support unit

The LP lifter transports single or multiple conveyor trays vertically between the multi-layer conveyor

SZ--4560 Legs (light duty)

SH--4590 Legs (heavy duty)

They are to be mounted directly next to the drive or driven unit, or below the conveyor section joints on the conveyor section units, with legs spaced at a maximum distance of 2000 mm.

SM - foundation bracket

Legs must be anchored to the ground with foot connectors and ground bolts

SZ 4560Legs (light duty)



Delivery note

Delivery involved

foot cup
Sensor

Recommended accessories

Foundation Bracket

Condition on delivery

Fully assembled

Legs for conveying monorail sections on a horizontal plane
Standard specifications, can be customized non-standard legs

Ordering information Dimensions

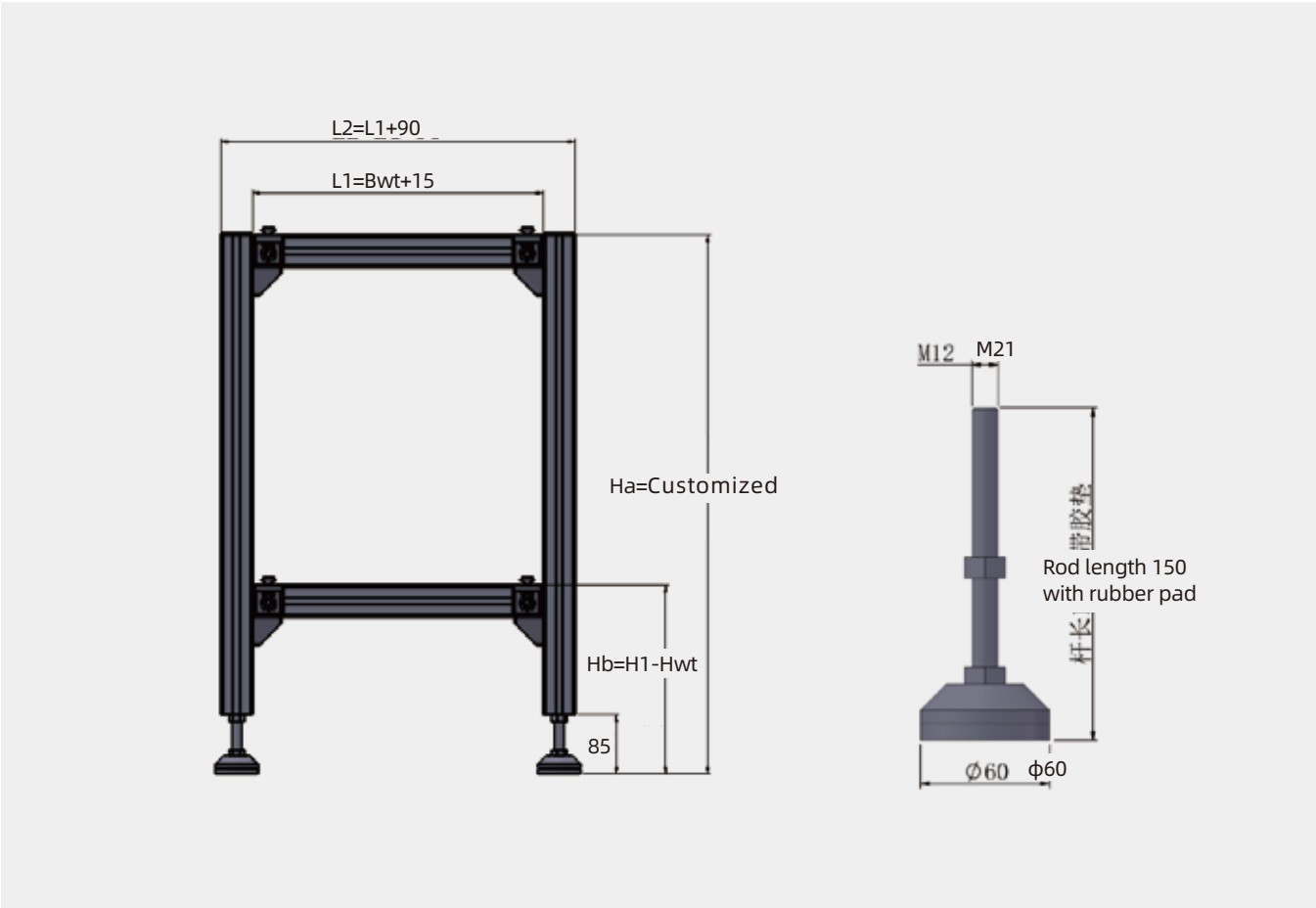

SH Legs (heavy duty)

Hwt-height difference between the upper and lower levels of the conveyor line can be used as a single-level leg.



Delivery note

Delivery involved

foot cup
Sensor

Recommended accessories

Foundation Bracket

Condition on delivery

Fully assembled

Legs for conveying monorail sections on a horizontal plane
Standard specifications, can be customized non-standard legs

Ordering information Dimensions

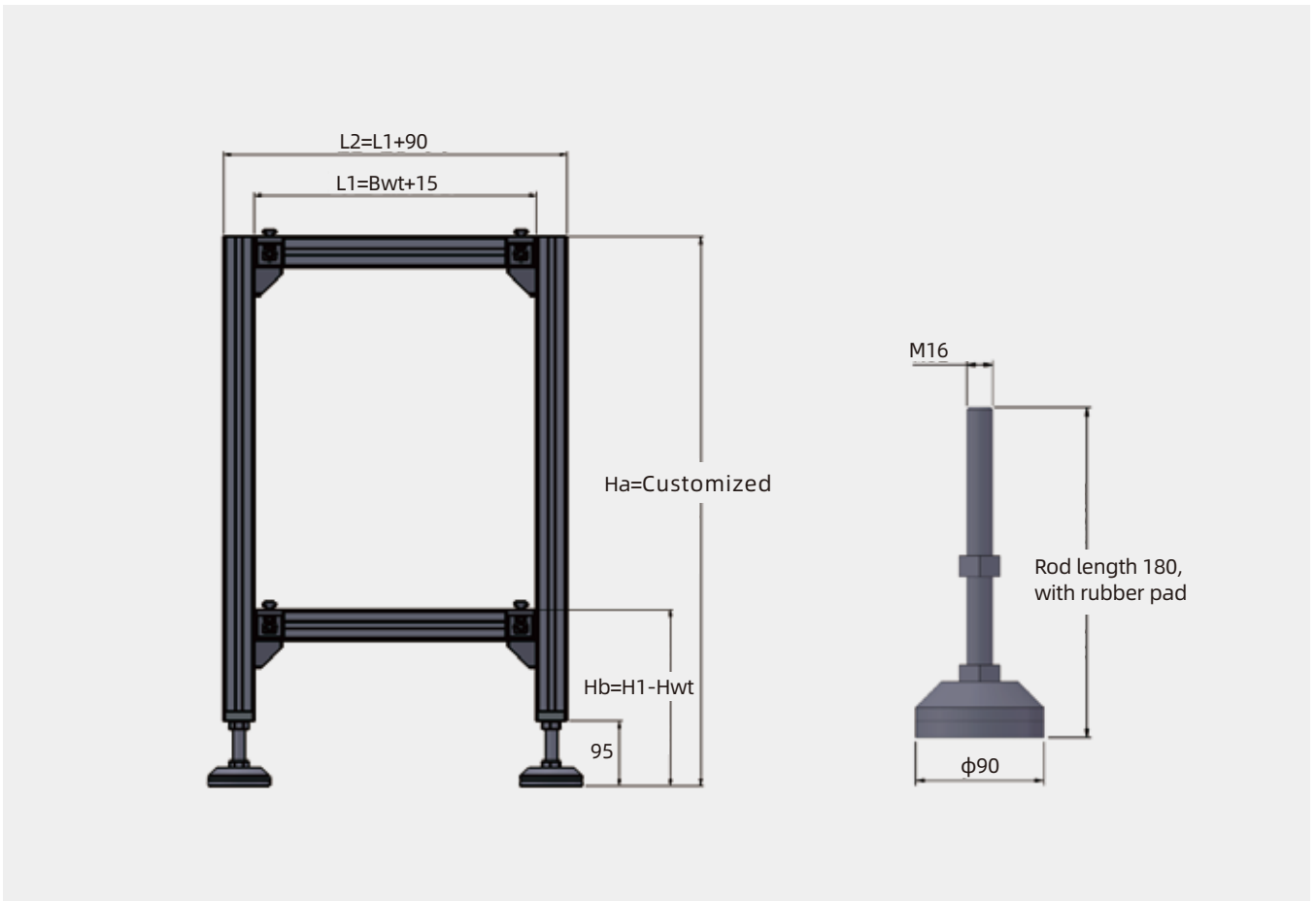

Customized model description

SZ	Legs specifications: SZ(4560 leg) SZH(4590 leg)
B <input type="checkbox"/>	Pallet width: B160 / B240 / B320 / B400 / B480 / B640 /Customized
Ha	Height of upper conveyor belt surface to floor
Hb	Height of upper conveyor belt surface to floor
<input type="checkbox"/>	S (Single) D (Double) Customized

订货范例

SZ—B320—900—500—D

Legs specifications:SZ

Pallet width:Bwt=320

Upper Height:900

Lower Height: 500

Number of leg layers:D(double)

SM Foundation Bracket



Delivery note

Delivery involved

Foundation Bracket

Sensor

Ground bolt

Condition on delivery

Fully assembled

- ▶ Foundation brackets are used to secure the legs to the ground.
- ▶ Standard specification

Ordering information Dimensions

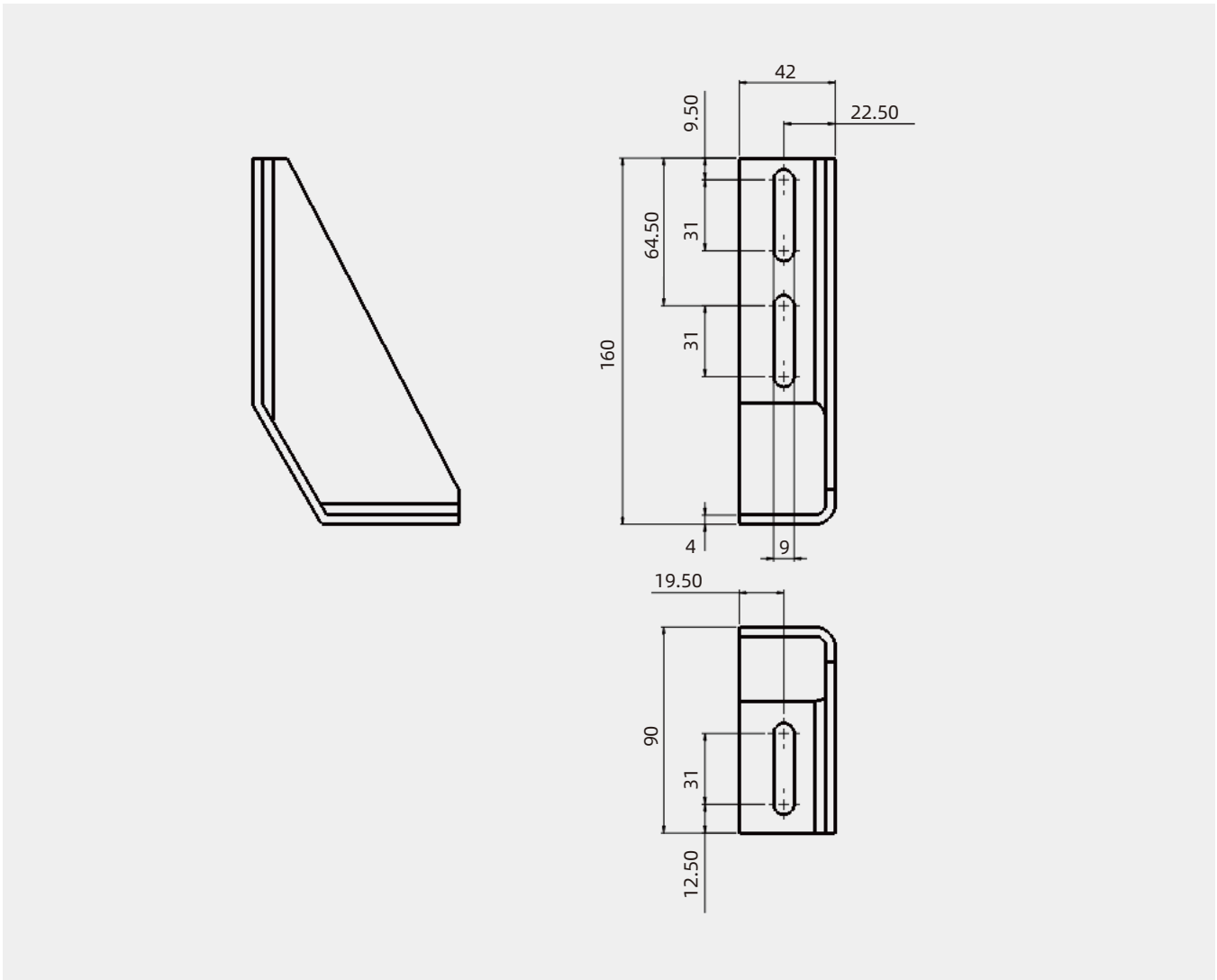

Product Description	SM Foundation Bracket
Ordering Model	SM.01.01

11

System specifications

**Use, Accumulated load, Functional safety,
Overloading, Load and conveying speed, Dielectric resistance
Effect of conveying speed on wear, Wear,
Effects of high/low loads on wear, Pneumatic connection**

System specifications

Use

The pallet conveyor system is a multi-functional system consisting of standard conveyor lines and modular mechanisms for conveying, stopping and positioning pallets of workpieces. Almost any system layout is possible with the appropriate components.

Functional safety

1. Resistance to media and contamination does not mean that safety can be guaranteed at all times.

2. Liquids that are thickened by evaporation and are highly viscous (sticky) may cause malfunctions.

3. If the medium used in systems for conveying by means of belts or round belts is lubricated, the driving force generated by friction may be reduced.

4. Chain lubricants for conveyor belts can be cleaned with solvents or detergents.

5. Special attention must be paid to these issues when planning and adjusting maintenance intervals for the system.

Dielectric resistance

Ensures resistance to wetting with many of the common media used in manufacturing, such as water, mineral oil, grease and detergents.

Accumulated load

1. The total weight of the wire body pallet accumulation is not allowed to exceed the maximum allowable load of the wire body.

2. Accumulation operation is not permitted on transverse conveyor and curve.

Overloading

1. Overloading of the conveyor belt may damage the conveying medium and the motor and drive teeth.

2. If pneumatic components are overloaded, proper function cannot be guaranteed.

Load and conveying speed

The workpiece pallet load rating is the value of the pallet load at standard conveying speeds and general operating conditions.

Effect of conveying speed on wear

The wear of the conveying medium is directly proportional to the conveying speed. This means that, relative to a standard speed of 12 m/min, if the conveyor is operated at a conveying speed of 18/min, the wear limit is reached at 12/18, i.e. 2/3 of the normal operating life.

Wear

Inevitable wear and tear is inevitable in the operation of the system. Certain measures, as well as the selection of suitable materials, will help to ensure the functional safety of the system during its life cycle, but wear and tear is affected by the operation, maintenance and the surrounding environment of the system and the place where it is situated (corrosion resistance, contamination).

The following measures will help reduce wear and the friction it causes:

- Shutting down the conveyor section when the system is not in operation (i.e., during breaks, overnights, or weekends).
- Select only the conveying speed corresponding to the specific function.
- Minimising the weight of workpiece pallets.
- Clean the conveying medium regularly.

Effects of high/low loads on wear

Higher loads may result in more wear and tear.

Pneumatic connection

Dry, filtered compressed air with or without oil.

Working pressure: 4-6 Bar

