

BGX / BGC SPECIFICATION TABLE

- i** Guide block design properties:
 - Low assembly and special assembly height (S and X)
 - Short, standard, long and extra long types with no flange (BS, BN, BL, BE)
 - Standard sealing option with end seals

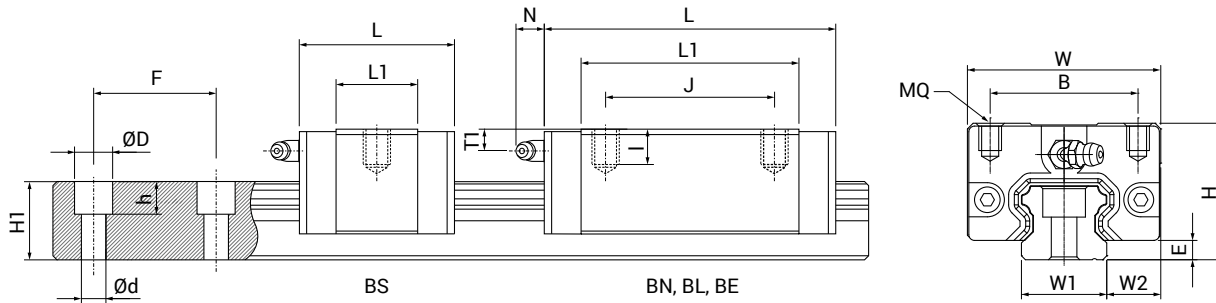

Model	Assembly [mm]				Block [mm]									Rail [mm]						Block kg	Rail kg/m
	H	W	W2	E	L	B	J	MQ	I	L1	Oil H	T1	N	W1	H1	F	d	D	h		
S15BS	24	34	9,5	3,4	40,6	26	-	M4	4,8	22,2	M4x0,7	5,5	(5,7)	15	13,0	60	4,5	7,5	5,5	0,10	1,28
S15BN	24	34	9,5	3,4	58,6	26	26	M4	4,8	40,2	M4x0,7	5,5	(5,7)	15	13,0	60	4,5	7,5	5,5	0,17	1,28
S15BL	24	34	9,5	3,4	66,1	26	26	M4	4,8	47,7	M4x0,7	5,5	(5,7)	15	13,0	60	4,5	7,5	5,5	0,18	1,28
S20BS	28	42	11,0	4,5	49,1	32	-	M5	5,5	27,5	M6x1,0	5,1	(12,3)	20	16,3	60	6,0	9,5	8,5	0,17	2,15
S20BN	28	42	11,0	4,5	70,1	32	32	M5	5,5	48,5	M6x1,0	5,1	(12,3)	20	16,3	60	6,0	9,5	8,5	0,26	2,15
S25BS	33	48	12,5	5,8	54,0	35	-	M6	6,8	32,3	M6x1,0	7,2	(12,2)	23	19,2	60	7,0	11,0	9,0	0,21	2,88
S25BN	33	48	12,5	5,8	79,2	35	35	M6	6,8	57,5	M6x1,0	7,2	(12,2)	23	19,2	60	7,0	11,0	9,0	0,38	2,88
X25BN	36	48	12,5	5,8	79,2	35	35	M6	9,0	57,5	M6x1,0	10,2	(12,2)	23	19,2	60	7,0	11,0	9,0	0,40	2,88
X25BL	36	48	12,5	5,8	93,9	35	35	M6	9,0	72,2	M6x1,0	10,2	(12,2)	23	19,2	60	7,0	11,0	9,0	0,54	2,88
X25BE	36	48	12,5	5,8	108,6	35	50	M6	9,0	86,9	M6x1,0	10,2	(12,2)	23	19,2	60	7,0	11,0	9,0	0,67	2,88
S30BS	42	60	16,0	7,0	64,2	40	-	M8	10,0	37,2	M6x1,0	10,0	(11,7)	28	22,8	80	9,0	14,0	12,0	0,50	4,45
S30BN	42	60	16,0	7,0	94,8	40	40	M8	10,0	67,8	M6x1,0	10,0	(11,7)	28	22,8	80	9,0	14,0	12,0	0,80	4,45
S30BL	42	60	16,0	7,0	105,0	40	40	M8	10,0	78,0	M6x1,0	10,0	(11,7)	28	22,8	80	9,0	14,0	12,0	0,94	4,45
S30BE	42	60	16,0	7,0	130,5	40	60	M8	10,0	103,5	M6x1,0	10,0	(11,7)	28	22,8	80	9,0	14,0	12,0	1,16	4,45
S35BS*	48	70	18,0	7,5	75,5	50	-	M8	10,0	44,5	M6x1,0	11,5	(11,5)	34	26,0	80	9,0	14,0	12,0	0,80	6,25
S35BN	48	70	18,0	7,5	111,5	50	50	M8	10,0	80,5	M6x1,0	11,5	(11,5)	34	26,0	80	9,0	14,0	12,0	1,20	6,25
S35BL	48	70	18,0	7,5	123,5	50	50	M8	10,0	92,5	M6x1,0	11,5	(11,5)	34	26,0	80	9,0	14,0	12,0	1,40	6,25
S35BE	48	70	18,0	7,5	153,5	50	72	M8	10,0	122,5	M6x1,0	11,5	(11,5)	34	26,0	80	9,0	14,0	12,0	1,84	6,25
S45BN	60	86	20,5	8,9	129,0	60	60	M10	15,5	94,0	M8x1,25	14,4	(10,8)	45	31,1	105	14,0	20,0	17,0	1,64	9,60
S45BL	60	86	20,5	8,9	145,0	60	60	M10	15,5	110,0	M8x1,25	14,4	(10,8)	45	31,1	105	14,0	20,0	17,0	1,93	9,60
S45BE	60	86	20,5	8,9	174,0	60	80	M10	15,5	139,0	M8x1,25	14,4	(10,8)	45	31,1	105	14,0	20,0	17,0	2,42	9,60
S55BN*	70	100	23,5	12,7	155,0	75	75	M12	18,0	116,0	M8x1,25	14,0	(10,8)	53	38,0	120	16,0	23,0	20,0	2,67	13,80
S55BL*	70	100	23,5	12,7	193,0	75	75	M12	18,0	154,0	M8x1,25	14,0	(10,8)	53	38,0	120	16,0	23,0	20,0	3,57	13,80
S55BE	70	100	23,5	12,7	210,0	75	95	M12	18,0	171,0	M8x1,25	14,0	(10,8)	53	38,0	120	16,0	23,0	20,0	3,97	13,80

* On request

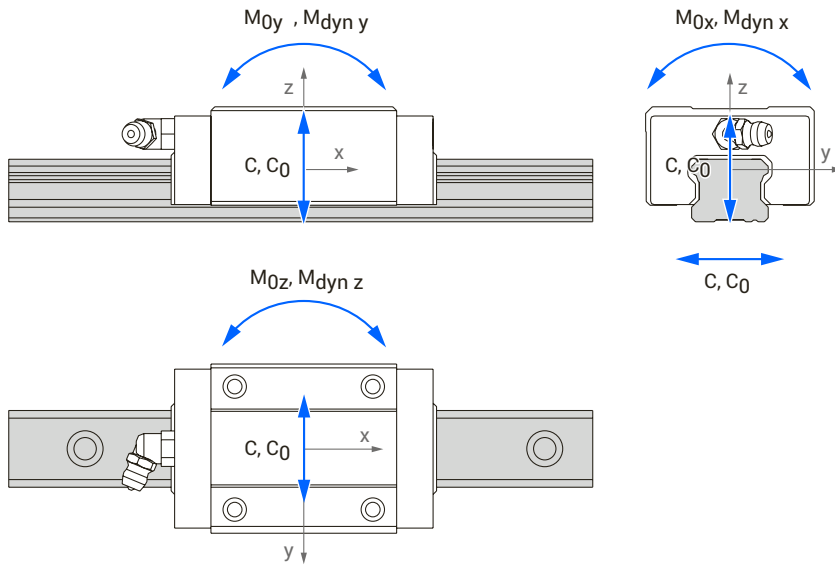

Model	Basic dynamic load rating [kN]		Basic static load rating [kN] C ₀	Permissible dynamic moment [Nm]						Permissible static moment [Nm]		
	C (BGX)	C (BGC)		M _{dyn x} (BGX)	M _{dyn y} (BGX)	M _{dyn z} (BGX)	M _{dyn x} (BGC)	M _{dyn y} (BGC)	M _{dyn z} (BGC)	M _{0x}	M _{0y}	M _{0z}
S15BS	4,6	5,7	9,8	32	15	15	40	19	19	68	32	32
S15BN	9,3	11,5	19,6	65	56	56	80	69	69	136	117	117
S15BL	11,3	13,9	23,7	78	81	81	96	99	99	164	169	169
S20BS	7,4	9,1	15,7	69	30	30	85	37	37	146	64	64
S20BN	14,3	17,7	30,5	134	103	103	165	128	128	285	220	220
S25BS	10,3	12,7	21,0	110	50	50	136	61	61	225	101	101
S25BN	20,1	24,8	41,1	215	172	172	265	212	212	440	352	352
X25BN	20,1	24,8	41,1	215	172	172	265	212	212	440	352	352
X25BL	25,9	31,9	52,8	278	279	279	342	343	343	566	568	568
X25BE	29,2	36,0	63,3	313	378	378	386	466	466	679	819	819
S30BS	14,7	18,2	27,0	191	82	82	236	101	101	350	150	150
S30BN	29,7	36,7	54,6	384	300	300	475	370	370	706	551	551
S30BL	38,5	47,5	70,7	498	447	447	615	552	552	915	821	821
S30BE	42,9	52,9	86,7	555	661	661	685	815	815	1122	1336	1336
S35BS	21,2	26,2	40,7	335	140	140	414	173	173	643	269	269
S35BN	42,4	52,3	81,1	670	508	508	827	627	627	1282	972	972
S35BL	52,9	65,4	101,4	836	728	728	1033	900	900	1602	1396	1396
S35BE	58,3	71,9	125,3	922	1064	1064	1137	1312	1312	1981	2286	2286
S45BN	58,0	71,6	108,9	1225	812	812	1512	1002	1002	2300	1524	1524
S45BL	69,0	85,1	129,5	1458	1131	1131	1798	1394	1394	2736	2122	2122
S45BE	79,7	98,4	163,3	1683	1649	1649	2078	2036	2036	3449	3379	3379
S55BN	69,8	86,2	133,4	1728	1206	1206	2134	1489	1489	3303	2304	2304
S55BL	94,2	116,3	178,9	2332	2159	2159	2879	2666	2666	4428	4101	4101
S55BE	127,7	157,7	253,6	3162	3252	3252	3905	4016	4016	6279	6458	6458

- i** Guide block design properties:
 - Low assembly and high assembly height (S and H)
 - Short, standard, long and extra long types with flange (FS, FN, FL, FE)
 - Standard sealing option with end seals

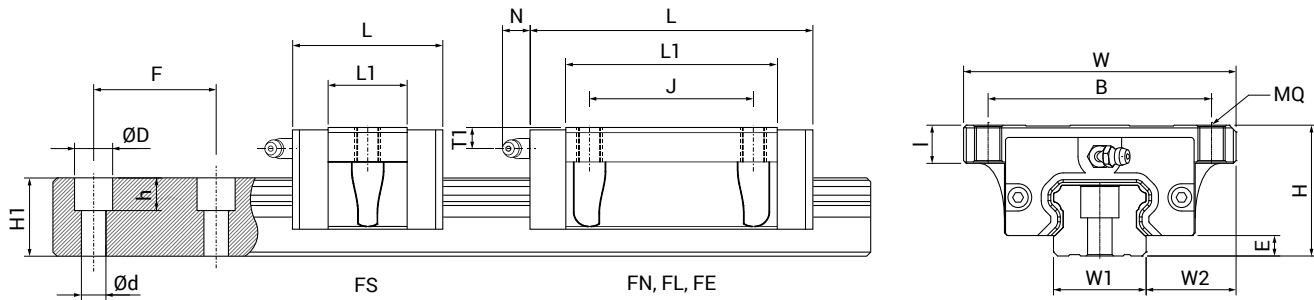

Model	Assembly [mm]				Block [mm]								Rail [mm]						Block [kg]	Rail [kg/m]	
	H	W	W2	E	L	B	J	MQ	I	L1	Oil H	T1	N	W1	H1	F	d	D			h
H15FN	24	47	16,0	3,4	58,6	38	30	M5	7,5	40,2	M4x0,7	5,5	(5,7)	15	13,0	60	4,5	7,5	5,5	0,21	1,28
H15FL	24	47	16,0	3,4	66,1	38	30	M5	7,5	47,7	M4x0,7	5,5	(5,7)	15	13,0	60	4,5	7,5	5,5	0,23	1,28
S15FS	24	52	18,5	3,4	40,6	41	-	M5	7,5	22,2	M4x0,7	5,5	(5,7)	15	13,0	60	4,5	7,5	5,5	0,12	1,28
S15FN	24	52	18,5	3,4	58,6	41	26	M5	7,5	40,2	M4x0,7	5,5	(5,7)	15	13,0	60	4,5	7,5	5,5	0,19	1,28
H20FN	30	63	21,5	4,5	70,1	53	40	M6	9,0	48,5	M6x1,0	7,1	(12,3)	20	16,3	60	6,0	9,5	8,5	0,40	2,15
H20FL	30	63	21,5	4,5	82,9	53	40	M6	9,0	61,3	M6x1,0	7,1	(12,3)	20	16,3	60	6,0	9,5	8,5	0,46	2,15
H20FE*	30	63	21,5	4,5	98,1	53	40	M6	9,0	76,5	M6x1,0	7,1	(12,3)	20	16,3	60	6,0	9,5	8,5	0,61	2,15
S20FS*	28	59	19,5	4,5	49,1	49	-	M6	7,0	27,5	M6x1,0	5,1	(12,3)	20	16,3	60	6,0	9,5	8,5	0,18	2,15
S20FN	28	59	19,5	4,5	70,1	49	32	M6	7,0	48,5	M6x1,0	5,1	(12,3)	20	16,3	60	6,0	9,5	8,5	0,31	2,15
H25FN	36	70	23,5	5,8	79,2	57	45	M8	10,1	57,5	M6x1,0	10,2	(12,2)	23	19,2	60	7,0	11,0	9,0	0,57	2,88
H25FL	36	70	23,5	5,8	93,9	57	45	M8	10,1	72,2	M6x1,0	10,2	(12,2)	23	19,2	60	7,0	11,0	9,0	0,72	2,88
H25FE*	36	70	23,5	5,8	108,6	57	45	M8	10,1	86,9	M6x1,0	10,2	(12,2)	23	19,2	60	7,0	11,0	9,0	0,89	2,88
S25FS*	33	73	25,0	5,8	54,0	60	-	M8	7,1	32,3	M6x1,0	7,2	(12,3)	23	19,2	60	7,0	11,0	9,0	0,33	2,88
S25FN*	33	73	25,0	5,8	79,2	60	35	M8	7,1	57,5	M6x1,0	7,2	(12,3)	23	19,2	60	7,0	11,0	9,0	0,50	2,88
H30FS*	42	90	31,0	7,0	64,2	72	-	M10	12,0	37,2	M6x1,0	10,0	(11,7)	28	22,8	80	9,0	14,0	12,0	0,80	4,45
H30FN	42	90	31,0	7,0	94,8	72	52	M10	12,0	67,8	M6x1,0	10,0	(11,7)	28	22,8	80	9,0	14,0	12,0	1,10	4,45
H30FL	42	90	31,0	7,0	105,0	72	52	M10	12,0	78,0	M6x1,0	10,0	(11,7)	28	22,8	80	9,0	14,0	12,0	1,34	4,45
H30FE*	42	90	31,0	7,0	130,5	72	52	M10	12,0	103,5	M6x1,0	10,0	(11,7)	28	22,8	80	9,0	14,0	12,0	1,66	4,45
H35FS*	48	100	33,0	7,5	75,5	82	-	M10	14,0	44,5	M6x1,0	11,5	(11,5)	34	26,0	80	9,0	14,0	12,0	1,00	6,25
H35FN	48	100	33,0	7,5	111,5	82	62	M10	14,0	80,5	M6x1,0	11,5	(11,5)	34	26,0	80	9,0	14,0	12,0	1,50	6,25
H35FL	48	100	33,0	7,5	123,5	82	62	M10	14,0	92,5	M6x1,0	11,5	(11,5)	34	26,0	80	9,0	14,0	12,0	1,90	6,25
H35FE*	48	100	33,0	7,5	153,5	82	62	M10	14,0	122,5	M6x1,0	11,5	(11,5)	34	26,0	80	9,0	14,0	12,0	2,54	6,25
H45FN	60	120	37,5	8,9	129,0	100	80	M12	16,0	94,0	M8x1,25	14,4	(10,8)	45	31,1	105	14,0	20,0	17,0	2,27	9,60
H45FL	60	120	37,5	8,9	145,0	100	80	M12	16,0	110,0	M8x1,25	14,4	(10,8)	45	31,1	105	14,0	20,0	17,0	2,68	9,60
H45FE*	60	120	37,5	8,9	174,0	100	80	M12	16,0	139,0	M8x1,25	14,4	(10,8)	45	31,1	105	14,0	20,0	17,0	3,42	9,60
H55FN*	70	140	43,5	12,7	155,0	116	95	M14	19,0	116,0	M8x1,25	14,0	(10,8)	53	38,0	120	16,0	23,0	20,0	3,44	13,80
H55FL	70	140	43,5	12,7	193,0	116	95	M14	19,0	154,0	M8x1,25	14,0	(10,8)	53	38,0	120	16,0	23,0	20,0	4,63	13,80
H55FE	70	140	43,5	12,7	210,0	116	95	M14	19,0	171,0	M8x1,25	14,0	(10,8)	53	38,0	120	16,0	23,0	20,0	5,16	13,80

* On request

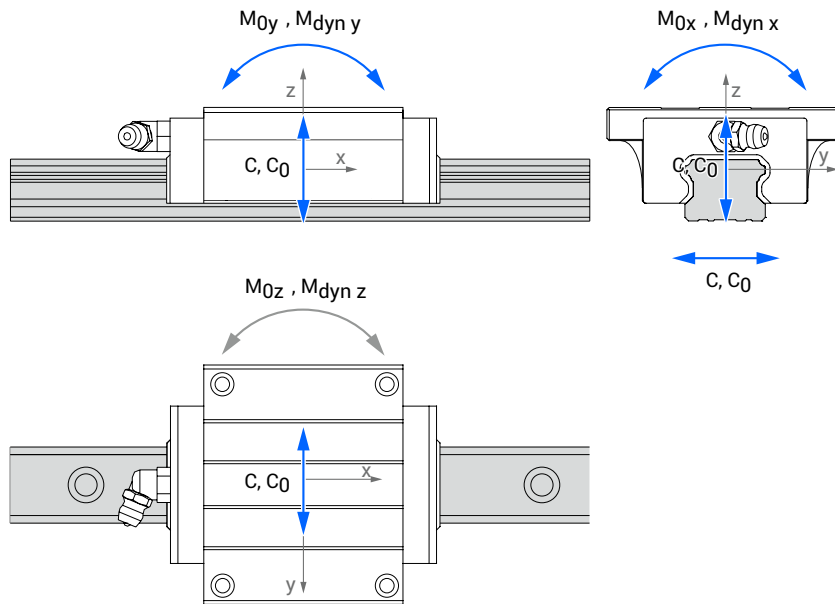

Model	Basic dynamic load rating [kN]		Basic static load rating [kN] C ₀	Permissible dynamic moment [Nm]						Permissible static moment [Nm]		
	C (BGX)	C (BGC)		M _{dyn x} (BGX)	M _{dyn y} (BGX)	M _{dyn z} (BGX)	M _{dyn x} (BGC)	M _{dyn y} (BGC)	M _{dyn z} (BGC)	M _{0x}	M _{0y}	M _{0z}
H15FN	9,3	11,5	19,6	65	56	56	80	69	69	136	117	117
H15FL	11,3	13,9	23,7	78	81	81	96	99	99	164	169	169
S15FS	4,6	5,7	9,8	32	15	15	40	19	19	68	32	32
S15FN	9,3	11,5	19,6	65	56	56	80	69	69	136	117	117
H20FN	14,3	17,7	30,5	134	103	103	165	128	128	285	220	220
H20FL	18,6	23,0	39,5	174	170	170	215	210	210	369	361	361
H20FE	22,1	27,3	48,9	206	252	252	255	311	311	456	557	557
S20FS	7,4	9,1	15,7	106	48	48	130	59	59	225	101	101
S20FN	14,3	17,7	30,5	134	103	103	165	128	128	285	220	220
H25FN	20,1	24,8	41,1	215	172	172	265	212	212	440	352	352
H25FL	25,9	31,9	52,8	278	279	279	342	343	343	566	568	568
H25FE	29,2	36,0	63,3	313	378	378	386	466	466	679	819	819
S25FS	10,3	12,7	21,0	110	50	50	136	61	61	225	101	101
S25FN	20,1	24,8	41,1	215	172	172	265	212	212	440	352	352
H30FS	14,7	18,2	27,0	191	82	82	236	101	101	350	150	150
H30FN	29,7	36,7	54,6	384	300	300	475	370	370	706	551	551
H30FL	38,5	47,5	70,7	498	447	447	615	552	552	915	821	821
H30FE	42,9	52,9	86,7	555	661	661	685	815	815	1122	1336	1336
H35FS	21,2	26,2	40,7	335	140	140	414	173	173	643	269	269
H35FN	42,4	52,3	81,1	670	508	508	827	627	627	1282	972	972
H35FL	52,9	65,4	101,4	836	728	728	1033	900	900	1602	1396	1396
H35FE	58,3	71,9	125,3	922	1064	1064	1137	1312	1312	1981	2286	2286
H45FN	58,0	71,6	108,9	1225	812	812	1512	1002	1002	2300	1524	1524
H45FL	69,0	85,1	129,5	1458	1131	1131	1798	1394	1394	2736	2122	2122
H45FE	79,7	98,4	163,3	1683	1649	1649	2078	2036	2036	3449	3379	3379
H55FN	69,8	86,2	133,4	1728	1206	1206	2134	1489	1489	3303	2304	2304
H55FL	94,2	116,3	178,9	2332	2159	2159	2879	2666	2666	4428	4101	4101
H55FE	127,7	157,7	253,6	3162	3252	3252	3905	4016	4016	6279	6458	6458

- i** Guide block design properties:
 - High assembly height (H)
 - Standard, long and extra long types with no flange (BN, BL, BE)
 - Standard sealing option with end seals

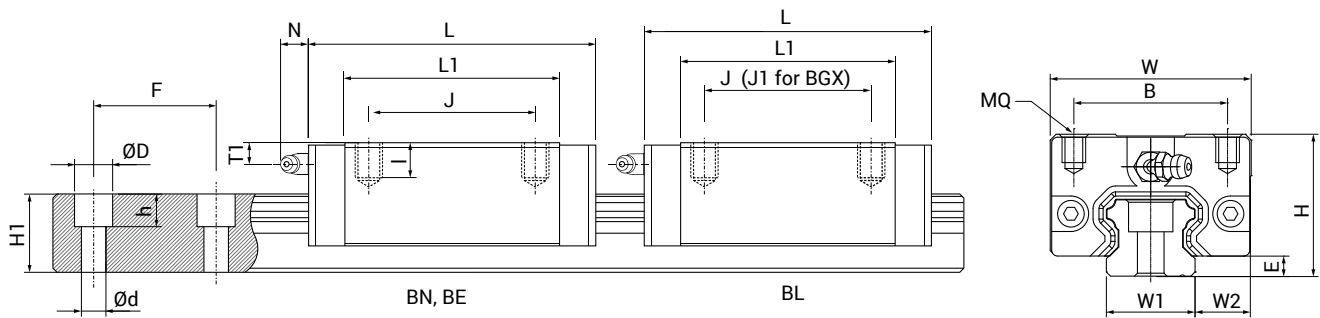

Model	Assembly [mm]				Block [mm]							Rail [mm]							Block kg	Rail kg/m		
	H	W	W2	E	L	B	J**	J1**	MQ	I	L1	Oil H	T1	N	W1	H1	F	d			D	h
H15BN	28	34	9,5	3,4	58,6	26	26	-	M4	6,0	40,2	M4x0,7	9,5	(5,7)	15	13,0	60	4,5	7,5	5,5	0,19	1,28
H20BN	30	44	12,0	4,5	70,1	32	36	-	M5	6,5	48,5	M6x1,0	7,1	(12,3)	20	16,3	60	6,0	9,5	8,5	0,31	2,15
H20BL	30	44	12,0	4,5	82,9	32	36	50	M5	6,5	61,3	M6x1,0	7,1	(12,3)	20	16,3	60	6,0	9,5	8,5	0,36	2,15
H20BE	30	44	12,0	4,5	98,1	32	50	-	M5	6,5	76,5	M6x1,0	7,1	(12,3)	20	16,3	60	6,0	9,5	8,5	0,47	2,15
H25BN	40	48	12,5	5,8	79,2	35	35	-	M6	9,0	57,5	M6x1,0	14,2	(12,2)	23	19,2	60	7,0	11,0	9,0	0,45	2,88
H25BL	40	48	12,5	5,8	93,9	35	35	50	M6	9,0	72,2	M6x1,0	14,2	(12,2)	23	19,2	60	7,0	11,0	9,0	0,66	2,88
H25BE	40	48	12,5	5,8	108,6	35	50	-	M6	9,0	86,9	M6x1,0	14,2	(12,2)	23	19,2	60	7,0	11,0	9,0	0,80	2,88
H30BN	45	60	16,0	7,0	94,8	40	40	-	M8	12,0	67,8	M6x1,0	13,0	(11,7)	28	22,8	80	9,0	14,0	12,0	0,91	4,45
H30BL	45	60	16,0	7,0	105,0	40	40	60	M8	12,0	78,0	M6x1,0	13,0	(11,7)	28	22,8	80	9,0	14,0	12,0	1,04	4,45
H30BE*	45	60	16,0	7,0	130,5	40	60	-	M8	12,0	103,5	M6x1,0	13,0	(11,7)	28	22,8	80	9,0	14,0	12,0	1,36	4,45
H35BN	55	70	18,0	7,5	111,5	50	50	-	M8	12,0	80,5	M6x1,0	18,5	(11,5)	34	26,0	80	9,0	14,0	12,0	1,50	6,25
H35BL	55	70	18,0	7,5	123,5	50	50	72	M8	12,0	92,5	M6x1,0	18,5	(11,5)	34	26,0	80	9,0	14,0	12,0	1,80	6,25
H35BE*	55	70	18,0	7,5	153,5	50	72	-	M8	12,0	122,5	M6x1,0	18,5	(11,5)	34	26,0	80	9,0	14,0	12,0	2,34	6,25
H45BN	70	86	20,5	8,9	129,0	60	60	-	M10	18,0	94,0	M8x1,25	24,4	(10,8)	45	31,1	105	14,0	20,0	17,0	2,28	9,60
H45BL	70	86	20,5	8,9	145,0	60	60	80	M10	18,0	110,0	M8x1,25	24,4	(10,8)	45	31,1	105	14,0	20,0	17,0	2,67	9,60
H45BE*	70	86	20,5	8,9	174,0	60	80	-	M10	18,0	139,0	M8x1,25	24,4	(10,8)	45	31,1	105	14,0	20,0	17,0	3,35	9,60
H55BN	80	100	23,5	12,7	155,0	75	75	-	M12	22,0	116,0	M8x1,25	24,0	(10,8)	53	38,0	120	16,0	23,0	20,0	3,42	13,80
H55BL*	80	100	23,5	12,7	193,0	75	75	95	M12	22,0	154,0	M8x1,25	24,0	(10,8)	53	38,0	120	16,0	23,0	20,0	4,57	13,80
H55BE*	80	100	23,5	12,7	210,0	75	95	-	M12	22,0	171,0	M8x1,25	24,0	(10,8)	53	38,0	120	16,0	23,0	20,0	5,08	13,80

* On request

** Dimension J is valid for BGC types and J1 for BGX types.

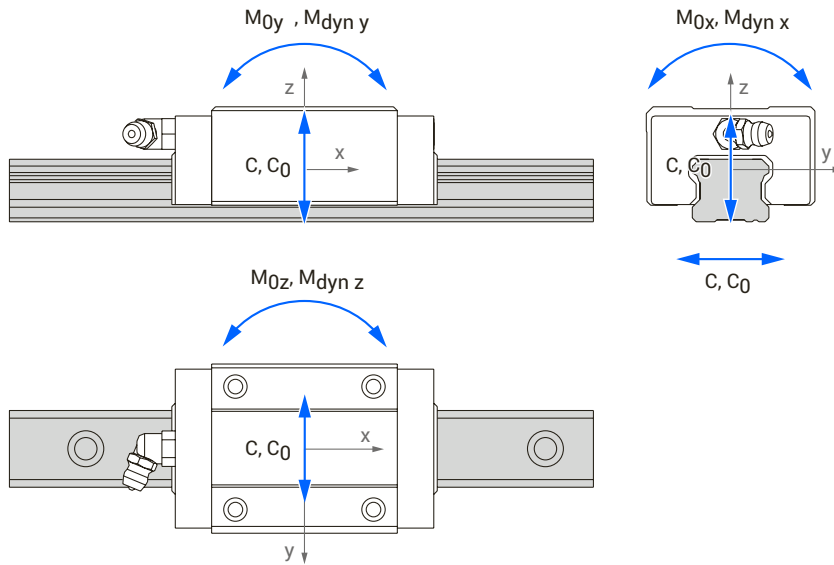

Model	Basic dynamic load rating [kN]		Basic static load rating [kN] C ₀	Permissible dynamic moment [Nm]						Permissible static moment [Nm]		
	C (BGX)	C (BGC)		M _{dyn x} (BGX)	M _{dyn y} (BGX)	M _{dyn z} (BGX)	M _{dyn x} (BGC)	M _{dyn y} (BGC)	M _{dyn z} (BGC)	M _{0x}	M _{0y}	M _{0z}
H15BN	9,3	11,5	19,6	65	56	56	80	69	69	136	117	117
H20BN	14,3	17,7	30,5	134	103	103	165	128	128	285	220	220
H20BL	18,6	23,0	39,5	174	170	170	215	210	210	369	361	361
H20BE	22,1	27,3	48,9	206	252	252	255	311	311	456	557	557
H25BN	20,1	24,8	41,1	215	172	172	265	212	212	440	352	352
H25BL	25,9	31,9	52,8	278	279	279	342	343	343	566	568	568
H25BE	29,2	36,0	63,3	313	378	378	386	466	466	679	819	819
H30BN	29,7	36,7	54,6	384	300	300	475	370	370	706	551	551
H30BL	38,5	47,5	70,7	498	447	447	615	552	552	915	821	821
H30BE	42,9	52,9	86,7	555	661	661	685	815	815	1122	1336	1336
H35BN	42,4	52,3	81,1	670	508	508	827	627	627	1282	972	972
H35BL	52,9	65,4	101,4	836	728	728	1033	900	900	1602	1396	1396
H35BE	58,3	71,9	125,3	922	1064	1064	1137	1312	1312	1981	2286	2286
H45BN	58,0	71,6	108,9	1225	812	812	1512	1002	1002	2300	1524	1524
H45BL	69,0	85,1	129,5	1458	1131	1131	1798	1394	1394	2736	2122	2122
H45BE	79,7	98,4	163,3	1683	1649	1649	2078	2036	2036	3449	3379	3379
H55BN	69,8	86,2	133,4	1728	1206	1206	2134	1489	1489	3303	2304	2304
H55BL	94,2	116,3	178,9	2332	2159	2159	2879	2666	2666	4428	4101	4101
H55BE	127,7	157,7	253,6	3162	3252	3252	3905	4016	4016	6279	6458	6458

How to order

Guide rail	35
Guide block	35

GUIDE RAIL

BGR - **25** - **N** - **550** - **40** / **G30**

Rail type:

- **BGR:** Standard rail
- **BGRC:** Tapped hole rail

Size:

- 15, 20, 25, 30, 35, 45, 55

Accuracy class:

- **N:** Normal
- **H:** High

Rail length L [mm]

Starting hole pitch L1 [mm]

End hole pitch L2 [mm]

End hole pitch L2 is calculated based on L, L1 and pitch F

Jointed end:

- **Leave blank:** Without jointed end
- **G:** Jointed end (ground surface)

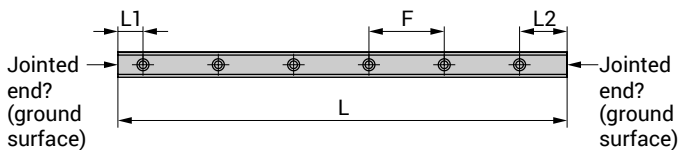

Unit: [mm]

Size	15	20	25	30	35	45	55
Pitch	60	60	60	80	80	105	120
L1, L2min	5	6	7	8	8	11	13
L1, L2max	55	54	53	72	72	94	107
Lmax	3940	3940	3940	3920	3920	3895	3880

GUIDE BLOCK

BGCH - **25** - **BL** - - **Z1** - **N**

Block type:

- **BGX:** Non-cage
- **BGC:** Cage

Assembly height:

- **H:** High assembly
- **S:** High assembly
- **X:** Special assembly

Size:

- 15, 20, 25, 30, 35, 45, 55

Type of flange and length:

- **BN:** No flange / standard
- **BL:** No flange / long
- **BE:** No flange / extra long
- **BS:** No flange / short
- **FN:** Flange / standard
- **FL:** Flange / long
- **FE:** Flange / extra long
- **FS:** Flange / short

Seal combination:

- **Leave blank:** With standard end + side seals
- **SS:** With standard end + side + inner seals

Accuracy class:

- **N:** Normal
- **H:** High

Preload:

- **Z1:** Light preload