

iASCENT Rail

KLAAR

Column mounted rope balancer

The iASCENT Rail allows effortless handling of up to 900kg. Fitting any type of rail system it is installed in the blink of an eye and overcomes the greatest distances with ease.



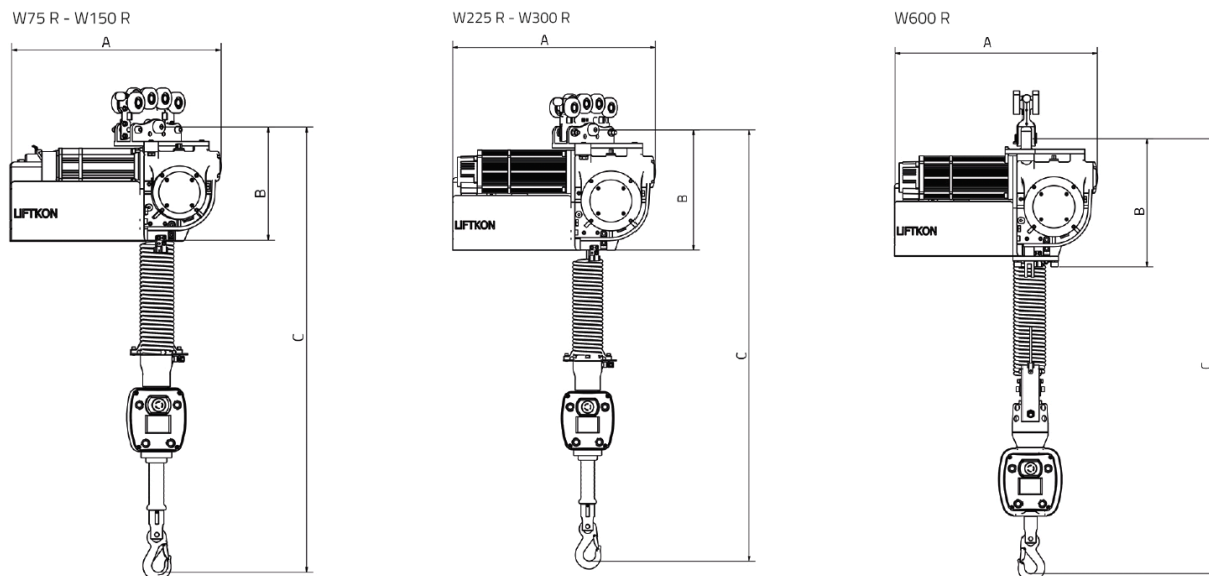

Type	A [mm]	B [mm]	C [mm]	Load capacity [kg]	Power supply	Max. lifting speed [mm/s]	Unit weight [kg]
K75 R	498	269	985	75	230 V / 1.700 VA / single-phase / 10 A / Typ C	650	31
K150 R	498	269	985	150	230 V / 1.700 VA / single-phase / 10 A / Typ C	392	31
K225 R	520	309	1025	225	230 V / 1.900 VA / single-phase / 10 A / Typ C	392	41
K300 R	520	309	1025	300	230 V / 1.900 VA / single-phase / 10 A / Typ C	327	41
K600 R	520	329	1118	600	230 V / 2.300 VA / single-phase / 10 A / Typ C	164	55

More technical data

Drive	Servomotor
Up / down movement	The ups and downs are initiated by the operating handle of the operating unit. Upon release the handle motion is immediately stopped.
Installation	In all types of rail systems.
Notice!	Type W600 R has an external handle.

Contact

Klaar GmbH
Kaiserau 2
51789 Lindlar

+49 (0)171 5440946
info@klaargmbh.de
www.klaargmbh.de

