



# COBOTS SERIES

CS | EC



## About Elite Robots

Elite Robots is a global automation solutions provider focusing on collaborative robots, also known as cobots. Founded in 2016 and headquartered in Shanghai, with a workforce of more than 300 people, it is the cobot manufacturer with the highest independent R&D rate in China, boasting over 150 registered patents.

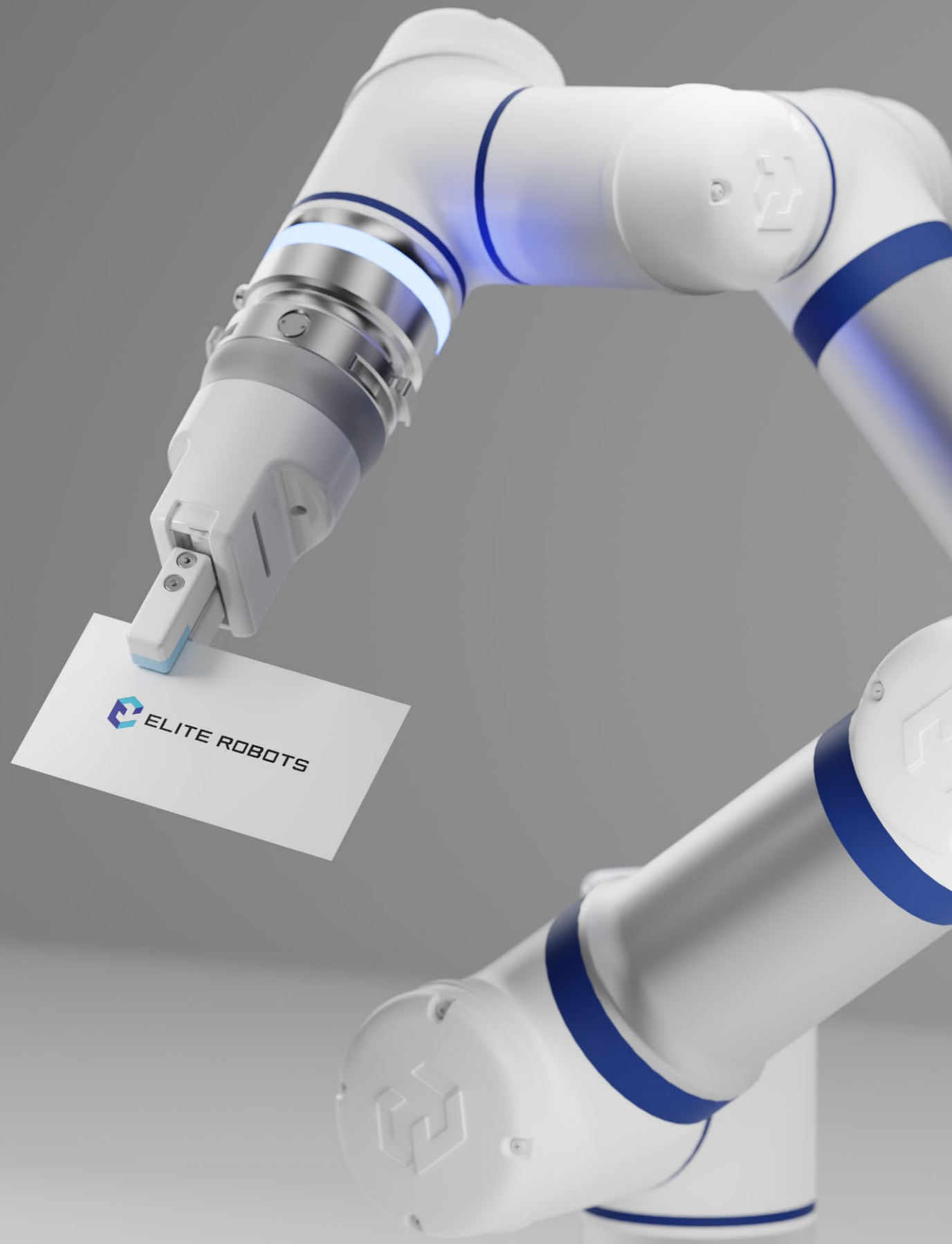
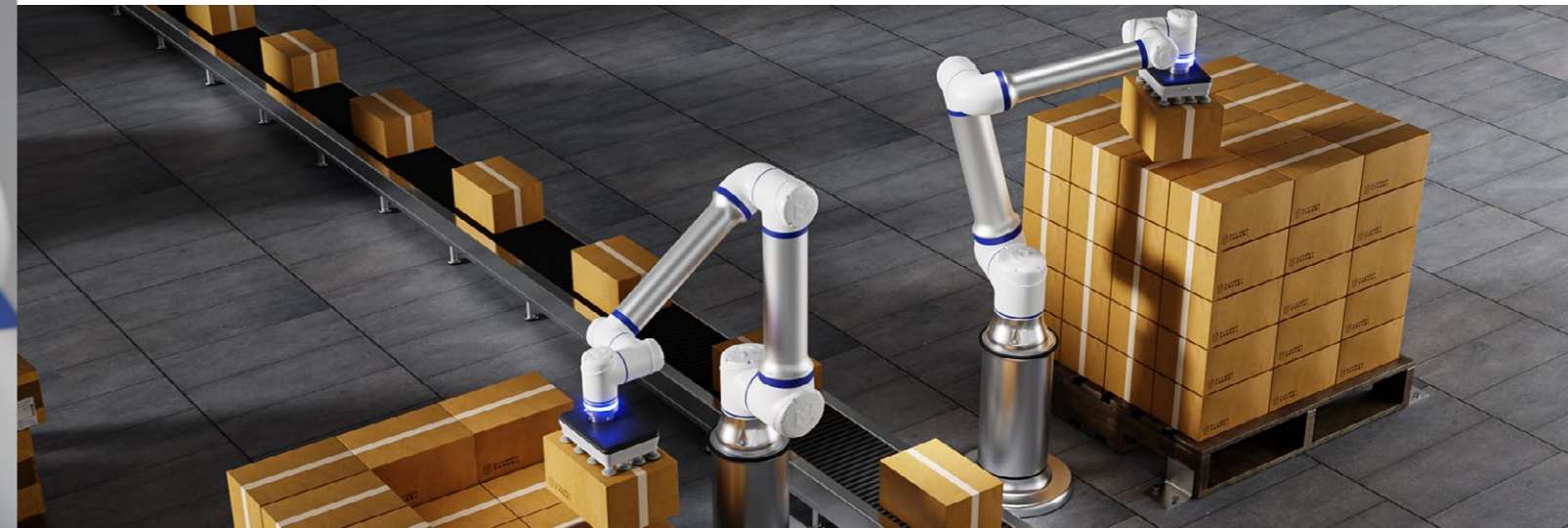

Constantly committed to developing cutting-edge yet accessible robotic solutions and improving human-machine interaction, continuous research and innovation are in the DNA of Elite Robots and the main driving forces behind its global growth.

By leveraging its partnerships with over 60 distributors and system integrators around the world, as well as collaborating with complementary automation equipment OEMs (ecopartners), the company has successfully deployed over 10,000 units across more than 30 countries. Elite Robots debuted in the cobotics arena by launching the EC Series, which quickly gained a growing reputation in the industry due to its stability, speed, and unmatched price-quality ratio.

The company was then among the pioneers in the development and mass production of second-generation collaborative robots, with the development of the new CS Series. Launched in late 2022, Elite Robots' new range of cobots features a brand-new infrastructure with extensive hardware and software upgrades which allow for greater flexibility and openness, enabling the robots to smoothly perform a variety of processing tasks.

In doing so, Elite Robots, whose automation solutions have already been successfully deployed across many industries (medical, automotive, electronics, metal processing, and energy, among others), will further expand the scope of its cobots, upgrading and empowering resilient businesses worldwide and the global industry as a whole.

**2016**  
Year founded

**300<sup>+</sup>**  
Employees

**150<sup>+</sup>**  
Patents

**10k<sup>+</sup>**  
Deployed Units

Elite Robots 8,700 square meters manufacturing site in Suzhou, China







# Cobots Range

## Cobot Superior CS SERIES

CS63 - CS66 - CS612 - CS620 - CS625

The CS Series is Elite Robots NextGen range of collaborative robots: a platform-level cobot based on a fully upgraded software & hardware infrastructure and an enhanced, customizable UX, providing extra safety, ease of use and high expandability, with payload up to 25kg and width up to 1800mm.

## Elite Cobots EC SERIES

EC63 - EC64-19 - EC66 - EC68-08 - EC612 - EC616

The EC Series sets itself apart in the cobotic world for its speed, flexibility, and reliability, as well as a leading price-quality ratio. Its robust and lightweight industrial design allows smooth multiangle installation and proper functioning in all environments.

# Track Record Across Industries



### Automotive

Successfully implemented multiple automation solutions in an industry that, due to the complexity of its supply chain, requires a wide variety of applications: engine and parts assembly, quality control, screwing, gluing, loading and unloading and so on.



### Electronics

The accuracy and ease of use and reprogramming of Elite Robots' cobots let them perfectly handle electronic products, which are characterized by high variety, small size, and short life cycles.



### FMCG

The need to maintain high turnover with no downtime and very low production costs is critical in the consumer goods industry, and all manufacturers that have implemented Elite Robots' reliable and cost-effective cobots in their lines have easily overcome this challenge.



### Metals & Machining

Due to their robustness, accuracy and extensive communication capabilities, Elite Robots' cobots have successfully handled the intricate tasks required in the demanding metal industry, making them the perfect choice for various metal-related applications.



### Logistic & Warehousing

Upgrade your packaging and palletizing tasks with Elite Robots cobotic solutions. With their payload capacities expanded from 16 to 25 kg, the new models offer an even wider range of applications.



### Education & Science

Enhance learning and support research with our accurate tabletop models. Used to simulate or assist high-precision experiments, they can work closely with students and scientists in order to provide the best hands-on experience.



### HoReCa

Under the wave of new modes of consumption, numerous retail businesses have successfully utilized Elite Robots' unmanned solutions for their operations, resulting in increased efficiency and customer satisfaction.



### Energy

Collaborative robots can be utilized across multiple stages of energy production, including assembly, inspection, and maintenance. They also offer a safe and effective solution for hazardous environments where human access can be dangerous.



### Medical

Demand for medical products has surged in recent years, and so have the automation needs of this industry, which Elite Robots has successfully met by serving companies of all sizes for a wide variety of applications, from pick and pack to material addition.

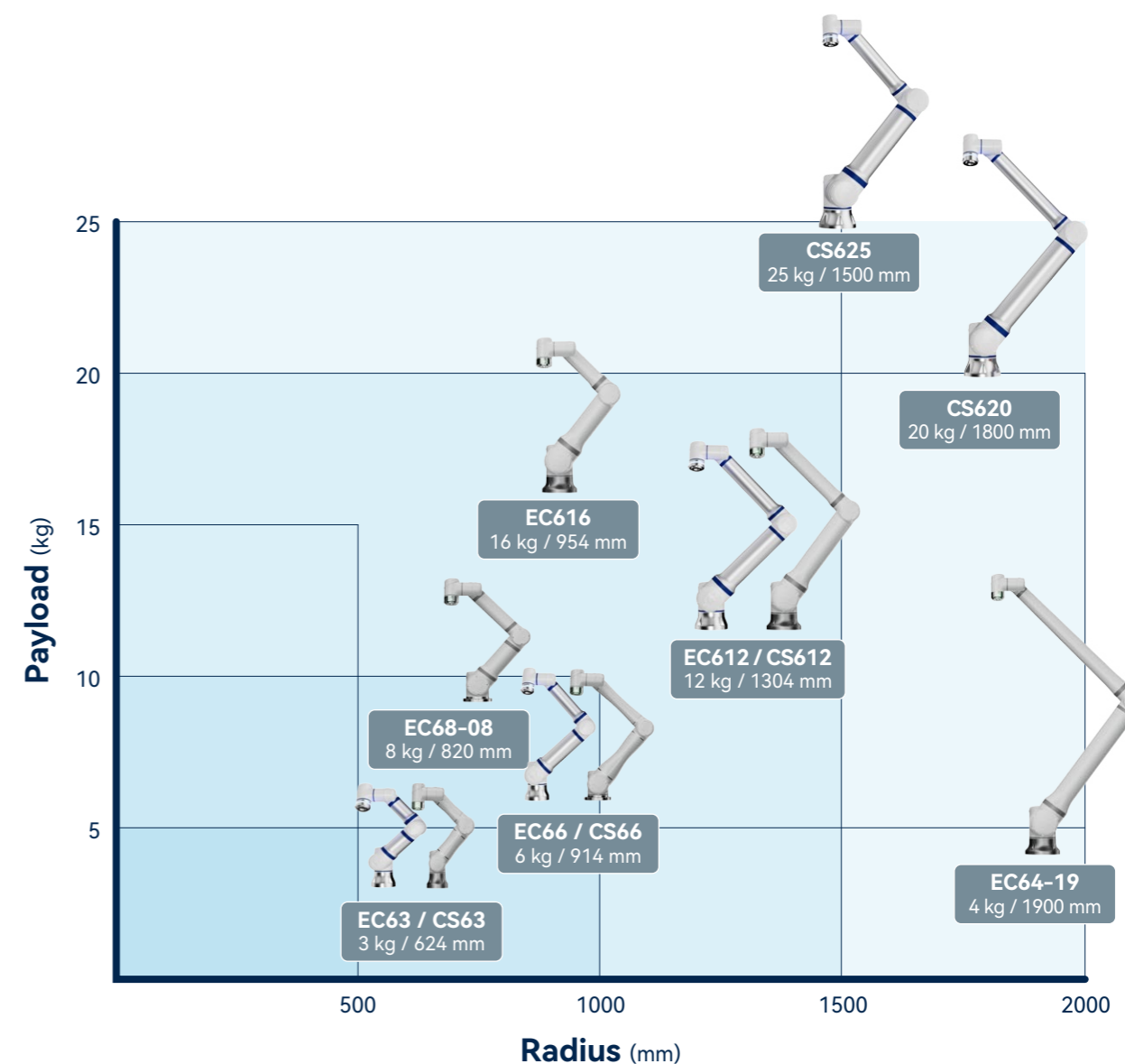



# CS SERIES

The NextGen Cobot is Here

Elite Robots' top-of-the-line solution for the most advanced automation requirements, the new CS series is ready to break more and more barriers to automation! With its easy programming and extensive communication capabilities, the CS series is the best solution for businesses looking to revamp or automate their production lines.

3~25 kg  
PAYLOAD

624~1800  
mm  
RADIUS

± 0.02~0.1  
mm  
ACCURACY

IP65/68  
PROTECTION  
RATING

## Your Superior Automation Partner

As the CS acronym (*Cobot Superior*) suggests, Elite Robots CS Series has been designed and developed with the aim of taking productivity to a superior level, by applying the 4-S PRINCIPLE: **Safe, Simple, Scalable, and Sustainable**.

- SAFE:**  
Designed in accordance with safety standards **ISO 10218-1** and **13849-1**, **PLd Category 3**, the CS Series integrates **over 20 configurable safety functions** and features **90 adjustable levels of collision detection**.
- SIMPLE**  
Intuitive, user-friendly, and customizable graphical user interface with flow chart software. Powerful, flexible, and versatile **Python-based programming language**.
- SCALABLE**  
Java-based expandable modular architecture. Rich interconnectivity (including **Profinet, Modbus RTU, ModbusTCP, Ethernet IP, RS485, and TCP/IP**) and **configurable IO ports** for enhanced communication and integration capabilities.
- SUSTAINABLE**  
The CS Series features a **standard IP65 degree of protection, upgradeable to IP68**, perfect for use in harsh environments and able to guarantee long uptimes with no need for periodic maintenance: a future-proof investment that will remain reliable and functional for years to come.





# CS SERIES

The NextGen Cobot is Here

## High payload capacity

With a load capacity of up to 25 kilograms, Elite Robots CS Series cobots are perfect for performing massive pick & place, palletizing and other heavy-duty applications with ease.



## User-friendly

Quick and easy to set up and redeploy. Graphic programming with preinstalled task-specific plugins. Full touch teach-pendant for smooth onsite operations.



## For any environment

Standard IP65 protection, upgradeable to IP68, allows the CS series collaborative robots to operate smoothly in even the harshest industrial environments.



## Ultra expandable

Compatibility with multiple protocols including Ethernet/IP, Profinet, Modbus. Supports custom plugins.



## Safe

ISO 10218 and ISO 13849 Cat3 PLd standards. Collision detection with 90 adjustable levels.



## Fast

3.9 m/s industry leading max tool speed. 4 ms SDK response time.





# CS SERIES

The NextGen Cobot is Here





**CS63**

**CS66**

**CS612**

**CS620**

**CS625**

	CS63	CS66	CS612	CS620	CS625
 PAYLOAD	3 kg	6 kg	12 kg	20 kg	25 kg
 RADIUS	624 mm	914 mm	1304 mm	1800 mm	1500 mm
 ACCURACY	±0.02 mm	±0.03 mm	±0.05 mm	±0.1 mm	±0.08 mm
 MAX TCP SPEED	2.0 m/s	2.8 m/s	3.4 m/s	3.9 m/s	3.3 m/s



**PROGRAMMING:**  
Python-script, graphic programming with tree-flow structure, embedded simulation SW, user-friendly plug-in creation, one-click back-up/restore/upgrade



**IO SIGNALS**  
Controller: 24 DI (8 config.) / 24 DO (8 config.), def. PNP (adjust. NPP), 4 HS DI. Terminal: 4 x config. TI/TO



**COMMUNICATION**  
3x Ethernet ports (1 HS @ 1 Gbps), 1x RS485, TCP/IP, MODBUS TCP/RTU, Ethernet/IP, Profinet, CCLink



**SAFETY**  
Pld. Cat. 3, ISO 13849; ISO 10218; safety config. IO; safety checksum



**IP PROTECTION RATING**  
Arm: IP65 (IP68 upgradable)  
Controller: IP44



**TOOL POWER CAPACITY**  
0 / 12v / 24v; 3A, 2A, 1A; 5A\*; RS485



**TEACH PENDANT**  
12,1" full-touch screen, tablet-like design



**STATUS LIGHT**  
Multi-color flange ring

\* CS620 and CS625 only



# CS SERIES



**Powerful**  
8 pin connector up to 3A capacity. Supporting def. PNP (adjust. NPN) and Push/Pull Output. Additional 4 pin connector with 5A capacity for the most demanding tasks (CS620 and CS625 only)

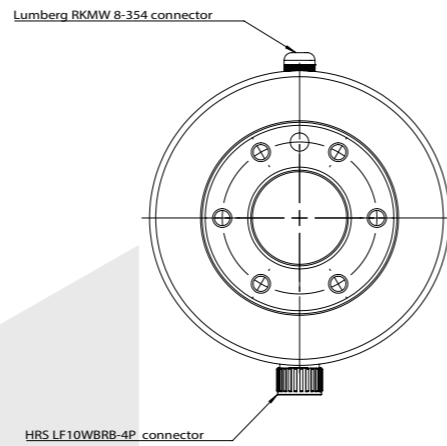

**Extra Safety**  
ISO 10218 and ISO 13849 Cat3 PLd standards. Adjustable collision detection with 90 selectable levels

**Suitable for all environments**

Sturdy robotic arm with standard IP65 protection upgradeable to IP68, to withstand dust, dirt and water. ISO class 5 cleanrooms

**Productivity at your fingertips**

12.1" Teach Pendant with full-touch capacitive screen. Ergonomic design for both left and right handed gripping. Easily detachable from controller for no-TP scenarios

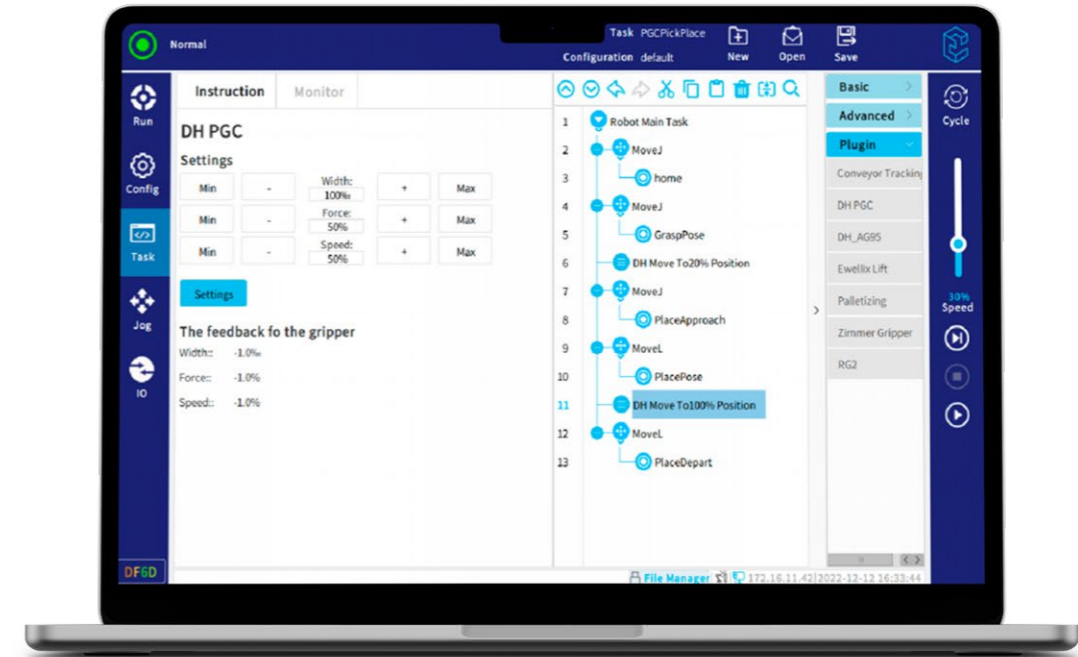

**User-friendly and Flexible UX**

Intuitive graphic interface with tree-flow structure and Python script, for both no-code operations and high-level programming. One-click upgrade/back-up/restore. Supports custom plugins for device, task and navigation configuration. Embedded simulation platform



**Integrated status-light**  
Multi-color ring on the cobot flange to clearly indicate the robot status (4 lights, 10 status)



**Highly Expandable**  
Compatible with multiple protocols. 24 DI (8 config.) / 24 DO (8 config.), 4 high-speed digital inputs. 3x Ethernet ports (1 HS @ 1 Gbps), 1x RS485





# Redefined User Experience



## Effortless Programming

The graphical programming method with a tree-flow structure is designed to streamline the robot programming process and is also suitable for beginners. Users can easily navigate the programming process through a simplified graphical interface. Complete Python parser fully supporting the Python scripting language, providing increased flexibility for high-level programming and achieving modular development. Tailored software interfaces can be developed to meet the security and functionality needs of every single user.

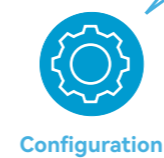

Configuration

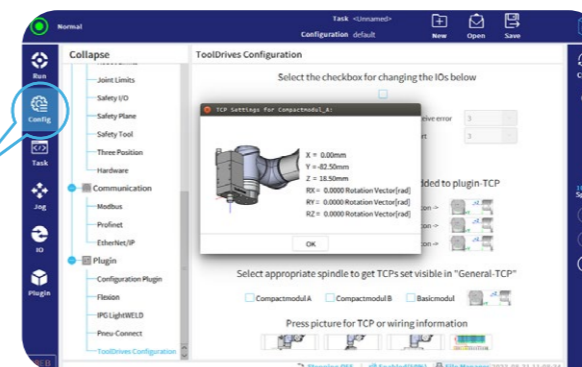

Task

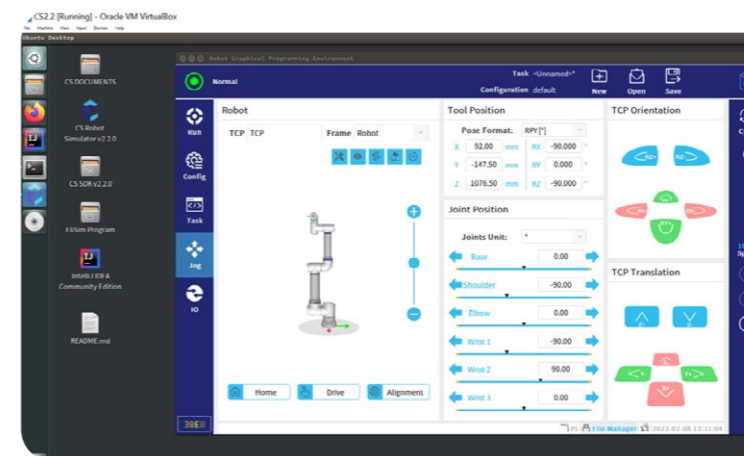
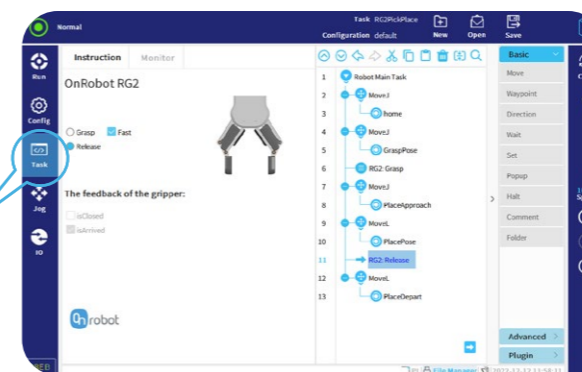

## Plugin Developing SDK

- Development of custom graphical plugins for configuration and task.
- The platform can be extended with various programming languages including Python, C, C++, and C#, among others.
- The standard Java development process leverages Intelligent IDEA, Eclipse, and Maven and other standard IDEs.
- ✓ Users can better integrate robots into their applications and processes.
- ✓ Integrators can increase their efficiency and value by adapting to the specific software needs of each user.

## Virtual Controller & Simulation Platform

Virtual platform specifically designed for robot simulation and offline programming. By replicating robot operations in a virtual environment, users can test, troubleshoot, and optimize them before implementing them on a real robot. The constructed program can be imported directly into a real robot.

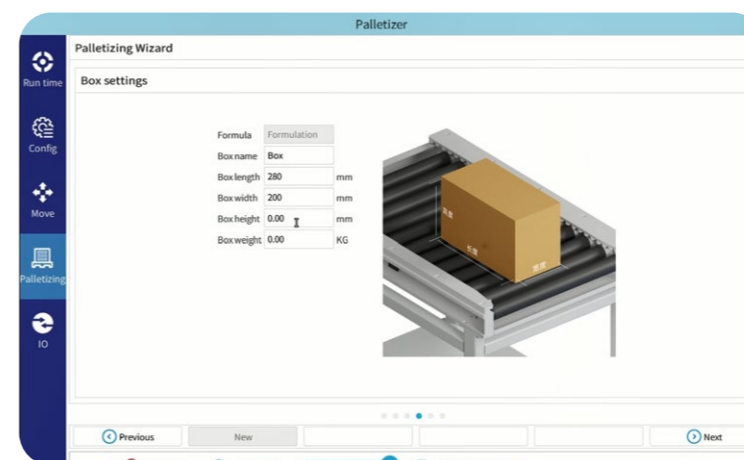

## Embedded Palletizing Wizard

The palletizing application wizard integrated in Elite Robots proprietary software ensures a fast and easy setup and redeployment. User-friendly and highly customizable, it is the perfect and cost-effective palletizing choice for multiple industries. Maximize your production efficiency and minimize operations downtime.

# CS SERIES



## Robotic Arm

	CS63	CS66	CS612	CS620	CS625
<b>Payload</b>	3kg	6kg	12kg	20kg	25kg
<b>Radius</b>	624mm	914mm	1304mm	1800mm	1500mm
<b>Repeatability</b>	±0.02mm	±0.03mm	±0.05mm	±0.1mm	±0.08mm
<b>Axis</b>	6				
<b>Joints rotation</b>	J1	±360°	±360°	±360°	±360°
	J2	±360°	±360°	±360°	±360°
	J3	±360°	±360°	±360°	±360°
	J4	±360°	±360°	±360°	±360°
	J5	±360°	±360°	±360°	±360°
	J6	±360°	±360°	±360°	±360°
<b>Joints speed</b>	J1-J2	180°/s	150°/s	120°/s	125°/s
	J3	230°/s	180°/s	150°/s	150°/s
	J4-J6	230°/s	230°/s	180°/s	210°/s
<b>Max TCP Speed</b>	2.0 m/s	2.8 m/s	3.4 m/s	3.9 m/s	3.3 m/s
<b>IP rating</b>	IP65 (IP68 upgradeable)				
<b>Temperature range</b>	-10~50°C				
<b>Relative humidity</b>	<90% (non-condensing)				
<b>Typical power usage</b>	185w	250w	435w	625w	625w
<b>Mounting</b>	Any angle				
<b>Tool I/O connector</b>	M8, 8pin		T1: M8, 8pin T2: Ø 12.8mm, 4pin		
<b>Tool I/O ports</b>	4 config. DI, 4 config. DO; 1 AI, 1 AO				
<b>Tool I/O power supply</b>	12V / 24V, 3A, 2A, 1A		T1: 12V/24V, 3A, 2A, 1A T2: 24V, 5A		
<b>Tool I/O communication</b>	RS485		RS485, CAN		
<b>Footprint</b>	Ø 128 mm	Ø 150 mm	Ø 190 mm	Ø 240 mm	Ø 240 mm
<b>Weight</b>	15 kg	20 kg	34 kg	60 kg	58 kg
<b>Material</b>	Aluminium, Steel				
<b>Cable length</b>	5.5m				
<b>Certifications</b>	ISO 10218-1, ISO 13849, ISO/TS 15066, RoHS, CE, UL, SEMI, ISO CLASS 5 Cleanroom				
<b>Programming</b>	Python-script, graphical proprietary user interface, free-drag/offline programming				

## Controller

<b>Type</b>	AC	
<b>I/O ports</b>	24 x DI (8 x DI config.), 24 DO (8 x DO config.); 2 x AI, 2 x AO, 4 x High Speed DI	
<b>I/O power supply</b>	24V/3A (internal), 6A (external)	
<b>Communication</b>	3 Ethernet, 1 RS485, TCP/IP, MODBUS TCP/RTU, EtherNet/IP slave, Profinet slave	
<b>Size (WxHxL)</b>	505mm x 462mm x 257mm	
<b>IP Rating</b>	IP44	
<b>Weight</b>	14kg*	16kg**
<b>Power source</b>	100-240 VAC, 50-60 Hz	
<b>Temperature range</b>	-10~50°C	
<b>Relative humidity</b>	5%~95% (non-condensing)	
<b>Material</b>	Aluminum, Steel	

\*For cobots: CS63, CS66, CS612

\*\*For cobots: CS620, CS625



## Teach Pendant

<b>Size (WxHxL)</b>	301mm x 232mm x 54mm
<b>Screen size</b>	12.1"
<b>Resolution</b>	1280 x 800 pixels
<b>IP rating</b>	IP54
<b>Weight</b>	1.7 kg
<b>Cable length</b>	5.5 m
<b>Temperature range</b>	-10~50°C
<b>Relative humidity</b>	5%~95% (non-condensing)
<b>Material</b>	Aluminum, plastic
<b>Input method</b>	Capacitive full touch-screen



# EC SERIES

## Meet the Elite Cobots

Reliable, safe and cost-effective, the EC (Elite Cobots) Series is the ideal productivity companion for all your processing tasks. Fast, lightweight, easy to install and operate, with an industry-leading payload to weight ratio of up to 0.49 and a maximum radius extension of 1900mm, the EC Series brings flexibility to your production process and rapid returns to your bottom-line.

3~16 kg  
PAYLOAD

624~1900  
mm  
RADIUS

± 0.02~0.1  
mm  
ACCURACY

## Make Complex Processes Simple

Elite Robots has established its presence in the world of industrial automation with its EC series collaborative robots. Known for their exceptional speed, flexibility, and reliability, as well as their excellent price-quality ratio, the EC cobots have helped many companies worldwide to optimize their manufacturing processes and boost productivity.

- **LIGHTWEIGHT**  
The world's first collaborative robots which weigh less and lift more, with a payload to self-weight ratio up to 0.49, for effortless lifting and carrying, and lower power consumption.
- **FLEXIBLE**  
Effortless multiangle installation (floor / wall / ceiling). Working radius with maximum extension of up to 1900mm to adapt to any working environment.
- **FAST**  
The EC Series stands out among its class with a maximum tool speed of 4.0 m/s, making it one of the fastest options available. Optimize your processing tasks with Elite Robots and experience unmatched speed and efficiency.
- **INDUSTRIAL DESIGN**  
The robust and streamlined robotic arm with IP54 rating can properly function even in non-optimal environmental conditions. Rugged industrial teach pendant with resistive touch-screen.

# EC SERIES

Meet the **Elite Cobots**

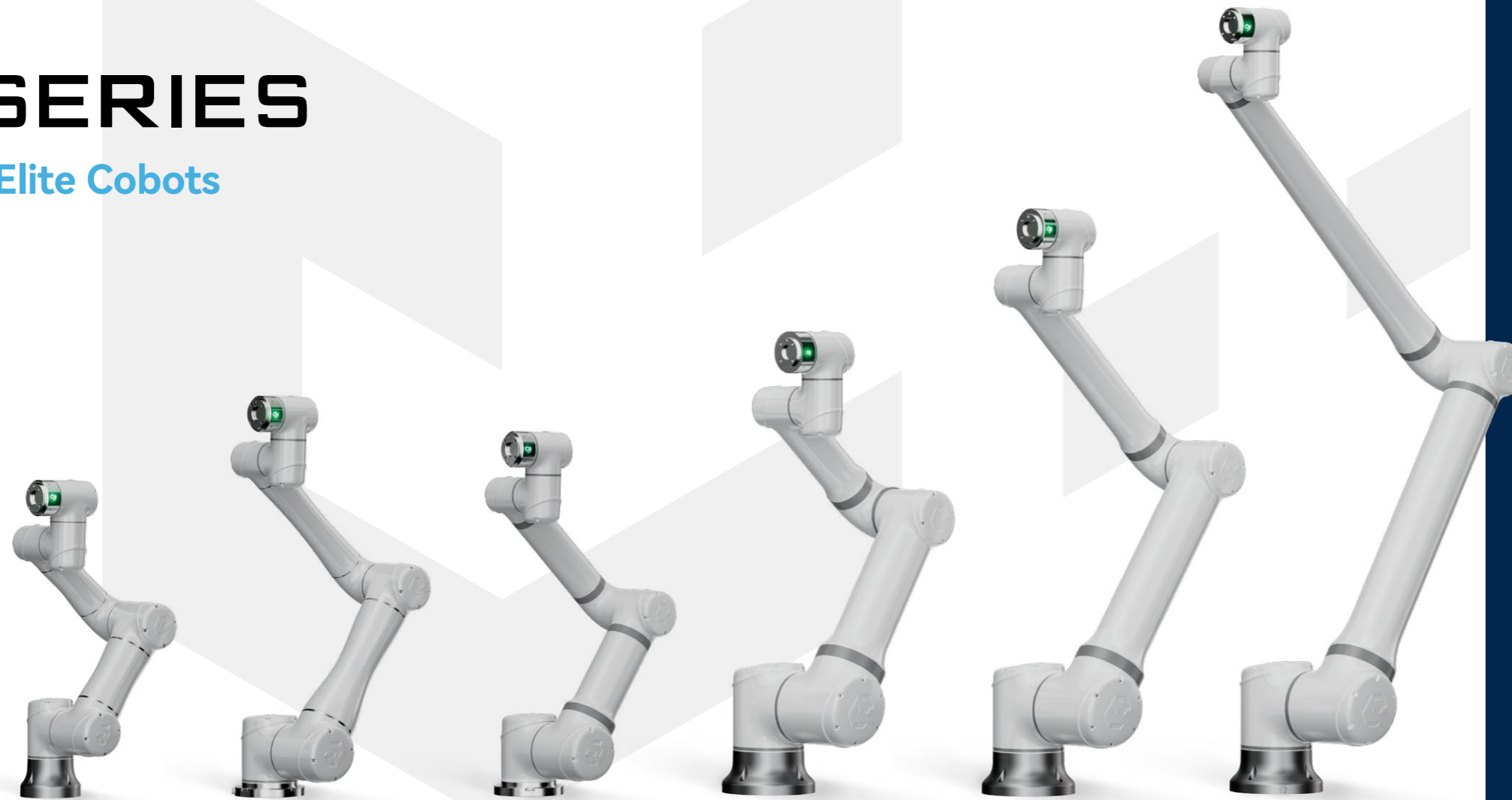

**EC63**

**EC66**

**EC68-08**

**EC616**

**EC612**

**EC64-19**



PAYLOAD

3 kg

6 kg

8 kg

16 kg

12 kg

4 kg



RADIUS

624 mm

914 mm

820 mm

954 mm

1304 mm

1900 mm



ACCURACY

±0.02 mm

±0.03 mm

±0.03 mm

±0.03 mm

±0.05 mm

±0.1 mm



MAX TCP SPEED

2.0 m/s

2.8 m/s

2.5 m/s

2.8 m/s

3.2 m/s

4.0 m/s



**PROGRAMMING:**  
 LUA-script, free-drag/offline programming



**IO SIGNALS**  
 Controller: 16 DI / 20 DO (8 config.), def. NPN (DI adjust. PNP)  
 Terminal: 2 x TI, 2 x TO



**COMMUNICATION**  
 1x Ethernet port, 1x RS485, TCP/IP, MODBUS TCP/RTU, Ethernet/IP, Profinet, CCLink



**SAFETY**  
 ISO 10218



**IP PROTECTION RATING**  
 Arm: IP54  
 Controller: IP44



**TOOL POWER CAPACITY**  
 24V/2A; RS485



**TEACH PENDANT**  
 Industrial panel with 8" resistive touch screen

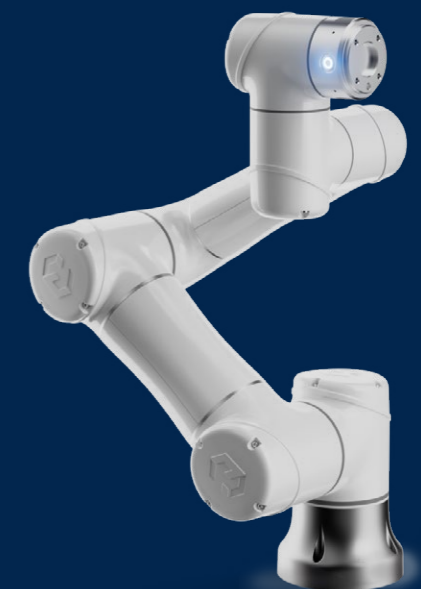



# EC SERIES

## Meet the Elite Cobots

**Free-drive and drag-and-teach function**

Move the cobot freely and smoothly teach it the running path.

**Collision detection**

Achieve safe human-machine interaction without worrying about collisions from your cobot.

**Wide Reach**

Maximum working radius extension up to 1900 mm for high flexibility and broad applications scope.

**Lightweight and compact design**

Multi-angle installation and IP54 protection allow the cobot to operate in any environment.

**Modular controller with open interface**

Supporting multiple communication options including TCP/IP, MODBUS TCP/RTU, and CCLink.



**Remote control via web teach-pendant**

Users can remotely interact with the cobot through Ethernet protocol via laptop, phone or pad. It allows real-time control and monitoring of the cobot (with 3D view display of its status), and more flexible programming.

**Rugged industrial teach pendant with resistive touch-screen**

Suitable for operating in the harshest environments.



# EC SERIES

## Robotic Arm

	EC63	EC64-19	EC66	EC68-08	EC612	EC616
<b>Payload</b>	3kg	4kg	6kg	8kg	12kg	16kg
<b>Radius</b>	624mm	1900mm	914mm	820mm	1304mm	954mm
<b>Repeatability</b>	±0.02mm	±0.1mm	±0.03mm	±0.03mm	±0.05mm	±0.03mm
<b>Axis</b>	6					
<b>Joints rotation</b>	J1	±360°	±360°	±360°	±360°	±360°
	J2	±360°	±360°	±360°	±360°	±360°
	J3	±360°	±360°	±360°	±360°	±360°
	J4	±360°	±360°	±360°	±360°	±360°
	J5	±360°	±360°	±360°	±360°	±360°
	J6	±360°	±360°	±360°	±360°	±360°
<b>Joints speed</b>	J1-J2	190°/s	120°/s	150°/s	150°/s	120°/s
	J3	190°/s	150°/s	190°/s	190°/s	150°/s
	J4-J6	260°/s	260°/s	260°/s	260°/s	210°/s
	J4-J6	260°/s	260°/s	260°/s	260°/s	210°/s
<b>Max TCP Speed</b>	2.0 m/s	4.0 m/s	2.8 m/s	2.5 m/s	3.2 m/s	2.8 m/s
<b>IP rating</b>	IP54					
<b>Temperature range</b>	-10~50°C					
<b>Relative humidity</b>	5%~95% (non-condensing)					
<b>Typical power usage</b>	185w	350w	250w	250w	435w	435w
<b>Mounting</b>	Any angle					
<b>Tool I/O connector</b>	12 pin					
<b>Tool I/O ports</b>	2 DI, 2 DO, 1 AI, 1 AO					
<b>Tool I/O power supply</b>	24V/2A					
<b>Tool I/O communication</b>	RS485					
<b>Footprint</b>	Ø 128 mm	Ø 200 mm	Ø 150 mm	Ø 150 mm	Ø 200 mm	Ø 200 mm
<b>Weight</b>	13kg	33.5kg	17.5kg	17kg	33.5kg	32.5kg
<b>Material</b>	Aluminium, Steel					
<b>Cable length</b>	5.5m					
<b>Certifications</b>	CE, CR, UL, KCs, RoHS-1					
<b>Programming</b>	LUA-script, free-drag/offline programming					



## Controller

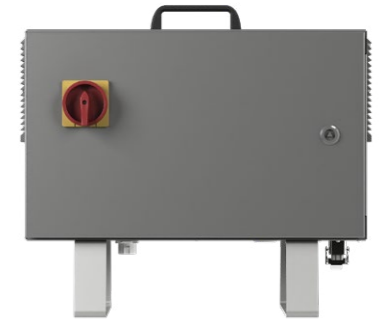

<b>Type</b>	AC / DC	
<b>I/O ports</b>	16 DI, 16 DO, 2 AI, 4 AO	
<b>I/O power supply</b>	24V; 2A (internal)	
<b>Communication</b>	Ethernet TCP/IP, UDP, Modbus TCP, RS485/RS232, ModbusRTU, Profinet slave, EthernetIP slave, CCLink slave (optional)	
<b>Size (WxHxL)</b>	505mm x 448mm x 245mm	
<b>IP rating</b>	IP44	
<b>Weight</b>	15kg*	17kg**
<b>Power source</b>	90-264VAC, 50-60Hz	
<b>Temperature range</b>	-10~50°C	
<b>Relative humidity</b>	5%~95% (non-condensing)	
<b>Material</b>	Aluminum, Steel	

\*For cobots: EC63, EC66, EC68-08

\*\*For cobots: EC64-19, EC612, EC616

## Teach Pendant



<b>Size (WxHxL)</b>	290mm x 225mm x 118mm
<b>Screen size</b>	8"
<b>Resolution</b>	800 x 600 pixels
<b>IP rating</b>	IP40
<b>Weight</b>	1.2 kg
<b>Cable length</b>	5.5 m
<b>Temperature range</b>	-10~50°C
<b>Relative humidity</b>	5%~95% (non-condensing)
<b>Material</b>	Aluminium, plastic
<b>Input method</b>	Resistive touch-screen, physical buttons, 3-positions key switch



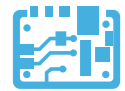

# Electronics



In this rapidly evolving industry, labor costs are a significant concern, particularly in the case of HMLV manufacturing. Flexibility is, therefore, critical, and electronics companies are actively seeking cobots that can be easily reprogrammed for new tasks or quickly redeployed to different production lines.

With Elite Robots' complete cobots range, companies in the 3C industry can achieve this level of flexibility, while also benefiting from certified safety features that permit human workers to work alongside the cobot (pending risk assessment) and perform tasks like loading and unloading, screwing, torquing, and inspecting.

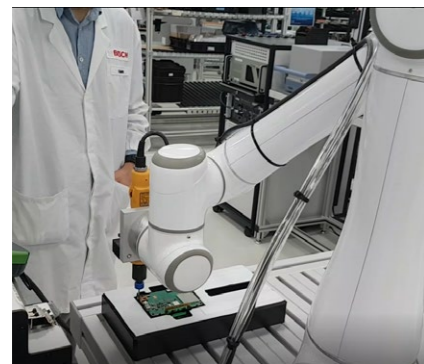

PCB board tightening at BOSCH plant



Loading & unloading with machine tending



Screwdriving



Pick & place of PCB boards



1-to-3 pick and place with machine tending



Injection of PCB boards

## Popular Applications

- Pick & Place
- Assembly & Screwdriving
- Quality Inspection
- Machine Tending
- Dispensing
- AGV Mobility
- 2D-/3D-Vision



# Automotive



The automotive manufacturing industry is renowned for having one of the most intricate and extensive supply chains across all sectors. It is composed of numerous small, medium, and large manufacturing firms that perform a diverse range of tasks, including machine loading, inspection, and assembly.

This industry has established a reputation for its strict standards and high productivity, and its ability to adapt quickly to changing consumer demands through customization and flexibility. Elite Robots has successfully addressed these demands over the years, catering to an expanding roster of Tier 1 OEMs and subcontractors.



Visual inspection



Tightening of engine bolts



Bearings mounting

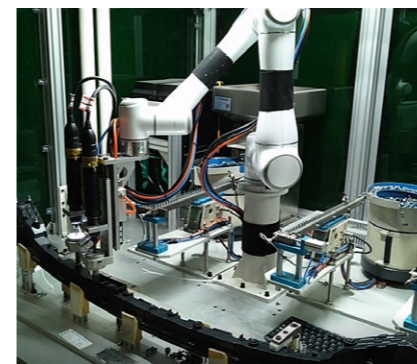

Taillights screwing



Screwing car body parts



Car seats visual inspection

## Popular Applications

- Machine Tending
- Quality Inspection
- Dispensing
- Assembly & Screwdriving
- Welding
- Polishing
- 2D-/3D-Vision





# Logistics & Warehousing



Logistics and warehousing are horizontal industries that have undergone significant advancements in recent years, largely driven by the rise of global e-commerce. However, these industries continue to face various challenges such as labor shortages, high labor costs, complex orders, shorter product cycles, and the need to ensure worker safety when dealing with heavy lifting and repetitive tasks.

Fortunately, Elite Robots has developed cutting-edge automation solutions in collaboration with its ecopartners. By leveraging these solutions, businesses can reduce their dependence on manual labor and significantly lower their operating costs. These automation technologies can automate many of the challenging tasks involved in logistics and warehousing, resulting in increased efficiency, productivity, and safety.



Mid-payload palletizing with lifter



Mixed palletizing demonstration



Palletizing simulation with AGV



Palletizing with lifter and gripper extender

## Popular Applications

-   
Pick & Place
-   
Palletizing
-   
AGV  
Mobility
-   
Quality  
Inspection
-   
Sorting
-   
2D-/3D-Vision



# Metal & Machining



This labor intensive industry is often characterized by 24/7 year round shifts, frequently in harsh environments and involving repetitive, physically demanding, and dangerous tasks. Significantly reduce the risk of workplace injuries and errors, and move your workers from undesirable workstations by deploying Elite Robots' cobots for your machine tending, drilling, and welding tasks.

With an accuracy of 0.02 mm, the IP65 rated robotic arm (upgradeable to IP68), and the effortless multi-angle installation (floor / wall / inclined / ceiling), you will achieve greater consistency in quality and promote worker satisfaction.



CNC machine tending with AGV



Drilling of metal sheets



Loading and unloading of engines at aerospace plant



Arc welding

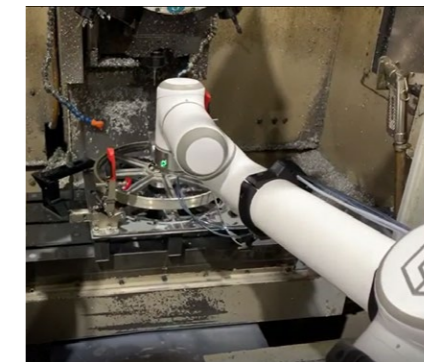



Loading and unloading of gears with machine tending



End cap loading

## Popular Applications

-   
Pick & Place
-   
Machine  
Tending
-   
Welding
-   
Quality  
Inspection
-   
Assembly &  
Screwdriving
-   
Material  
Removal





# HoReCa (hotels, restaurants, catering)



Robots are gradually becoming an integral part of our lives, no longer remaining confined to production facilities or labs, but also performing customer-facing tasks and other retail-related activities.

Restaurants, kiosks, fast food outlets, hotels and more are increasingly making use of robots that can provide non-stop, top-class service while boosting their bottom line.

Elite Robots has been involved in the development of automated coffee, ice cream, tea and other unmanned stations for retail consumption since 2017, successfully serving numerous companies, including large MNCs, and also deploying its cobots at some major national events.

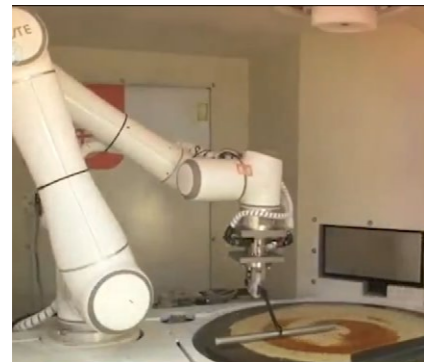

Making pancakes at World Robot Conference



Preparing and serving ice-cream at KFC



Double-arm coffee brewing demo



Serving tea during the National Congress



Preparing and serving bubble tea

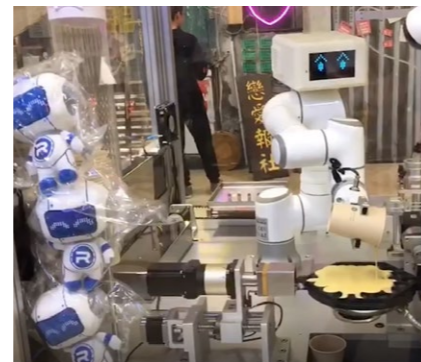

Waffle preparation

## Popular Applications



Cooking



Coffee Making



Drink Making



Serving



# More Industries & Applications



Salt cores pick & place with vision system



Palletizing in the FMCG industry at P&G plant



Electric cars fueling with AGV



Integration with industrial robot for bus body painting



Power plant IR inspection



End of line pick and pack in medical industry

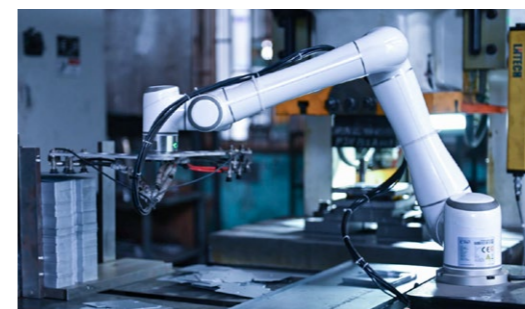

Pick & place of metal parts



Screwdriving



# Global Case Studies

From palletizing to assembly, from inspection to finishing, Elite Robots has successfully tackled thousands of automation challenges across all continents. Whether it is inspecting a power plant, tapping a gear, screwing taillights or preparing a snack, its cobots are helping companies of all sizes around the world increase efficiency and uptime, and boost their bottom line. By

seamlessly integrating its robotic arms with cutting-edge EoATs and other add-ons from leading manufacturers, and leveraging its extensive global network of partners, Elite Robots has implemented tailor-made cobotic solutions to meet any automation need. Explore some of its case studies to discover how.

## Empowering the metal industry

Qingdao Machinery, an established company in the metallurgical industry, has successfully transitioned from traditional to collaborative robotics with Elite Robots, resulting in safer and more cost-effective HMLV production. The switch allowed for enhanced safety and user-friendliness, reduced downtime, and created a flexible solution for multiple manufacturing applications.

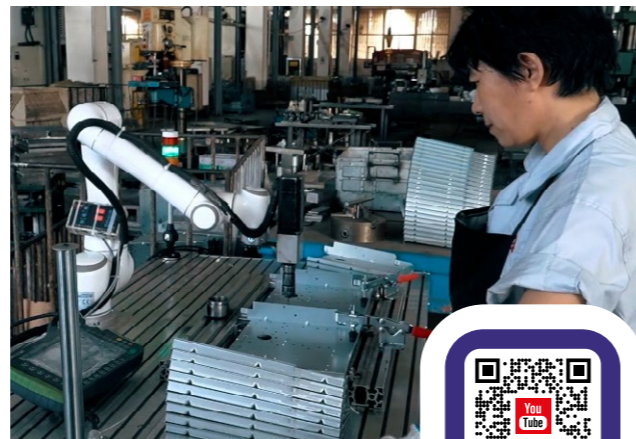

### Applications

- Pick & Place
- Material Removal

## Automating salt core production

Due to the demanding concentration and precision required in salt-core production, coupled with a suboptimal working environment, this supplier to global automotive brands decided to automate a portion of their production process. Elite Robots EC66 robotic arm, featuring an interchangeable gripper and 3D camera integration, proved to be a rapid and effective solution, both in terms of implementation and return on investment.



### Applications

- 2D-/3D-Vision
- Pick & Place

## Streamlining plastic processing

In order to meet the growing demand for one of their products, an established Portuguese company in the plastic industry needed a flexible and cost-effective automated solution to replace manual labor. The choice therefore fell on Elite Robots' EC66 robotic arm, which efficiently manages the material handling process, occupying little space and significantly reducing labor costs.



### Applications

- Machine Tending
- Pick & Place

## Solving labor shortage

After moving its production site to a first-tier city, a biotech company partnered with leading firms started experiencing labor shortages. To tackle the problem without disrupting production, the company opted for the "progressive automation model" proposed by Elite Robots. By adopting a table-top solution with multiple pick and place and PLC, the company was able to address labor shortages without altering the production process layout.

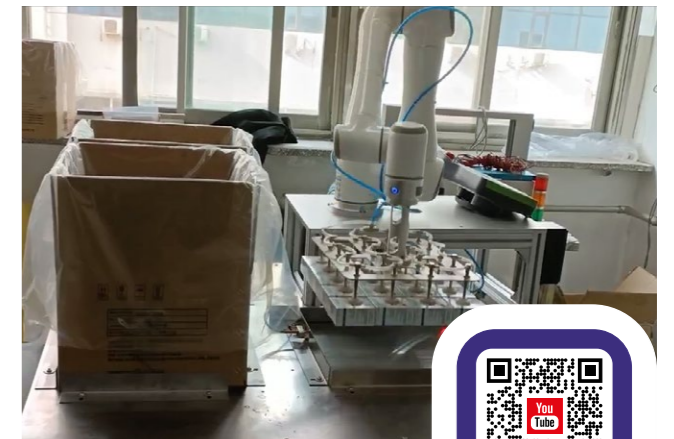

### Applications

- Pick & Place

## Safer tapping with cobots

The noise and harshness in the work environment prompted this Spanish metal component company to automate the tapping process of one of its products with Elite Robots' robot arms. Equipped with a customized EoAT, the Ec612 collaborative robot performs the entire gear tapping process, relieving workers from operating in a noxious and dangerous environment.

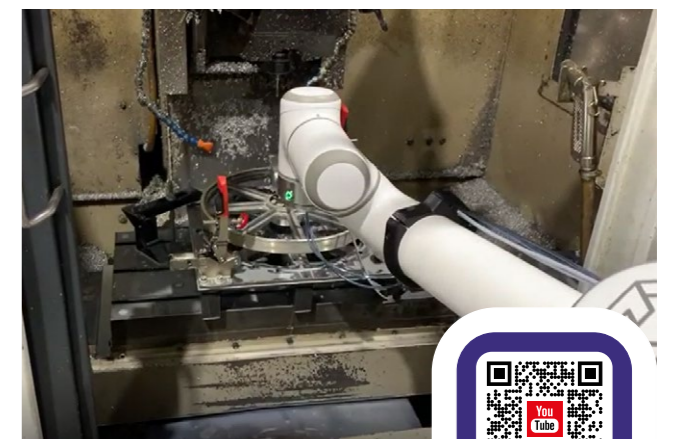

### Applications

- Machine Tending



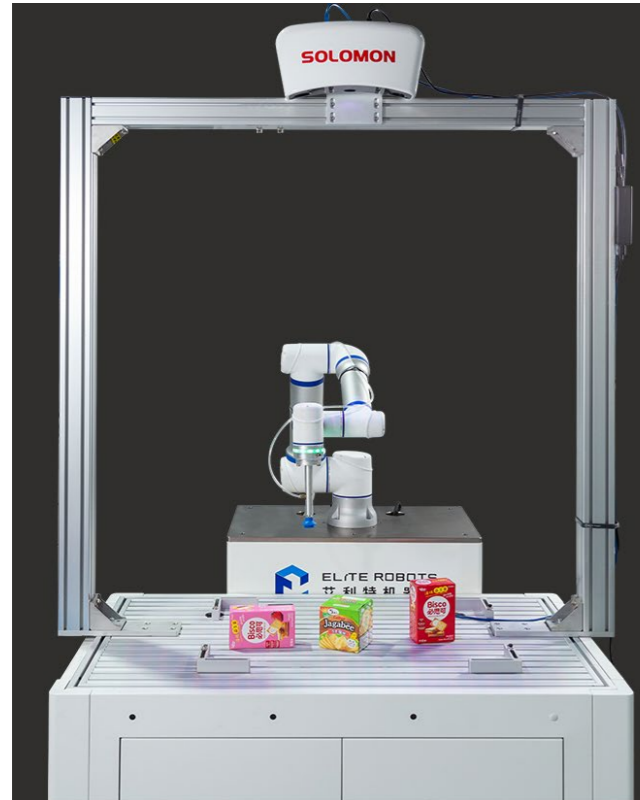

### End of Arm Tooling (EOAT)



Gimatic EQC gripper

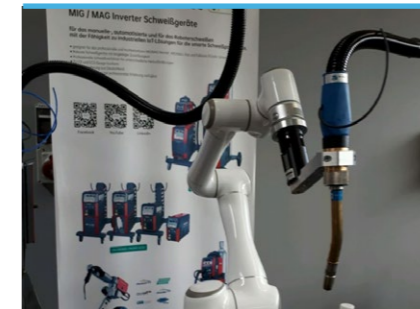

Megmeet welder



OnRobot electric gripper



SRT Robotics soft gripper



OnRobot sander



SMC pneumatic grippers

## A Broad Ecosystem

Instead of relying on a “one size fits all” approach and acknowledging that no one can excel in every aspect of robotics, Elite Robots leverages the expertise of a network of specialized third-party manufacturers, known as eco-partners, producing end-effectors and other add-ons for its cobot arms. Elite Robots can thus provide its users with a diverse and flexible range of options, ensuring that the best

solution is deployed for each automation project. This approach allows customers to combine Elite Robots’ robotic arm with equipment that meets their specific needs, whether it be grippers, vision sensors, or AGVs. Move away from the standardized approach typical of traditional robotics scenarios and create a customized solution that fits your unique needs!

### Vision systems

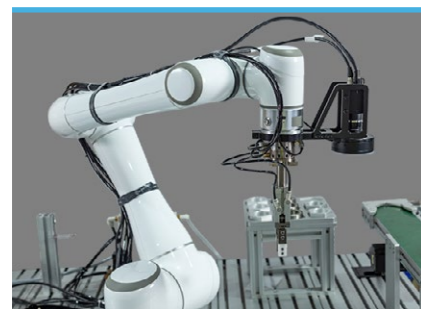

HikVision 2D camera



Scantech Simscan 3D scanner



Sorting solution with Solomon 3D camera

### Automated Guided Vehicles (AGV)



Machine tending with Standard Robots AGV



Palletizing solution with Youibot AGV



Demo for e-vehicles fueling with Geek+ AGV



# We are there for You. Worldwide.

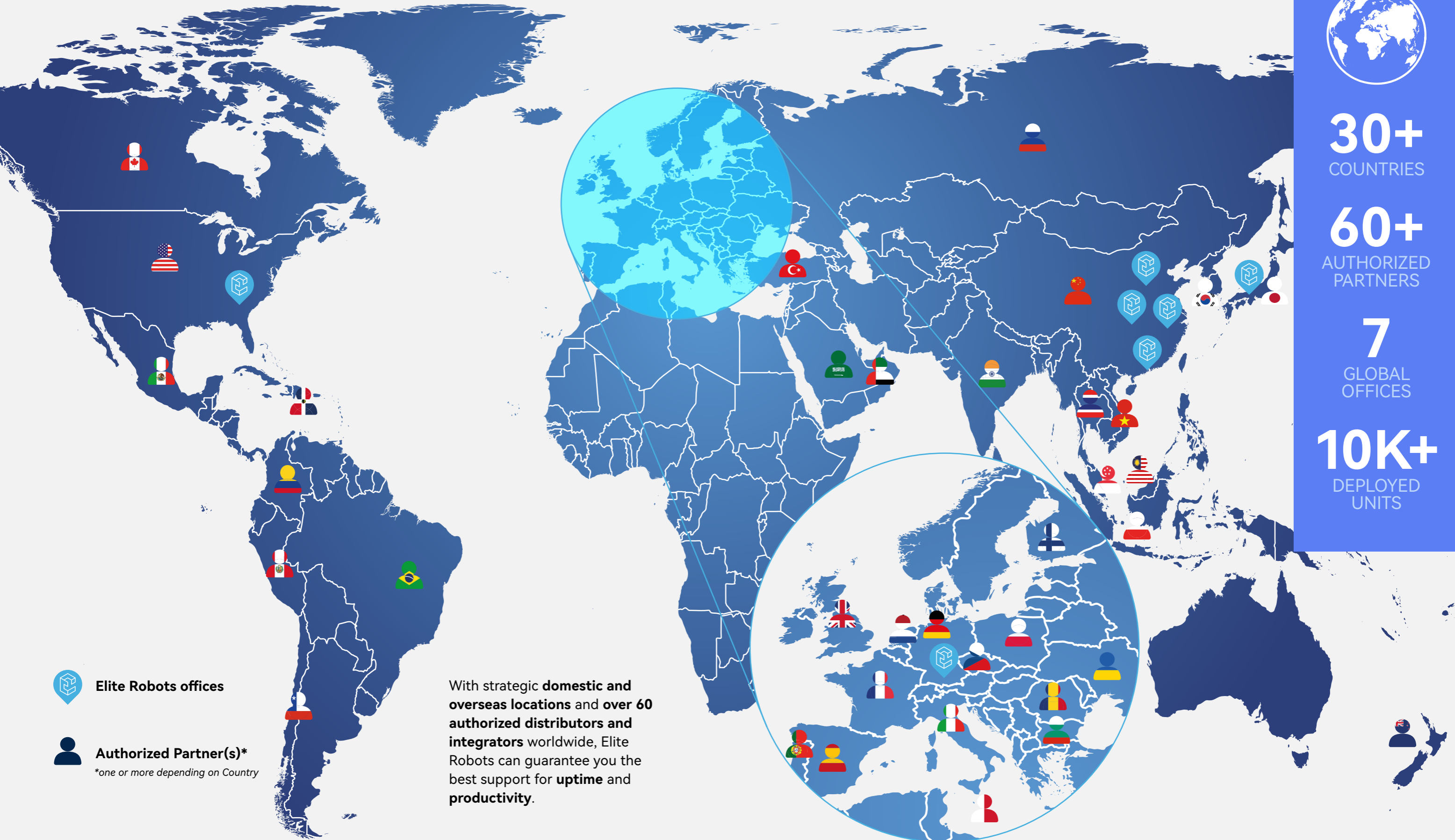

 Elite Robots offices

 Authorized Partner(s)\*  
*\*one or more depending on Country*

With strategic **domestic and overseas locations** and over **60 authorized distributors and integrators** worldwide, Elite Robots can guarantee you the best support for **uptime** and **productivity**.



**30+**  
COUNTRIES

**60+**  
AUTHORIZED PARTNERS

**7**  
GLOBAL OFFICES

**10K+**  
DEPLOYED UNITS



# CS SERIES

CS620

CS612

CS63

CS625

CS66



- **HEADQUARTERS**

**Elite Robots Shanghai Ltd.**  
Xuelin Road 36, Bldg. 18  
201210, Shanghai  
China  
Ph: +86 400 1899358

- **MANUFACTURING SITE**

**Suzhou Elite Robots Co., Ltd.**  
Changyang Road 259, Bldg. 4  
215123, Suzhou  
China  
Ph: +86 0512 83951898

- **NORTH & SOUTH AMERICA OPERATIONS CENTER**

**Elite Robots Inc.**  
10521 Research Dr., Ste 104  
37932, Knoxville, TN  
United States  
Ph: +1 865 392 1215

- **EMEA OPERATIONS CENTER**

**Elite Robots Deutschland GmbH**  
Münchener Str. 53  
85290, Geisenfeld  
Germany  
Ph: +49 8452 7330091

- **JAPAN OPERATIONS CENTER**

**Elite Robot Japan Co., Ltd.**  
TOSHIN Hirokoji Honmachi Bldg., 1F, 2-4-3  
Nagoya, 460-0008  
Japan  
Ph: +81 52 291442

[www.eliterobots.com](http://www.eliterobots.com)

 Elite Robots

 @EliteRobotsOfficial / @EliteRobotsTech