

# Whole-line Packaging Solution Provider

01

**box maker**

02

**packing**

03

**Sealing**

04

**stacking**



[www.egroecoauto.com](http://www.egroecoauto.com)

Email: [info@egroeco.com](mailto:info@egroeco.com)

Wechat/WhatsApp: +8618112630156

# Effect display

**EGROECO**

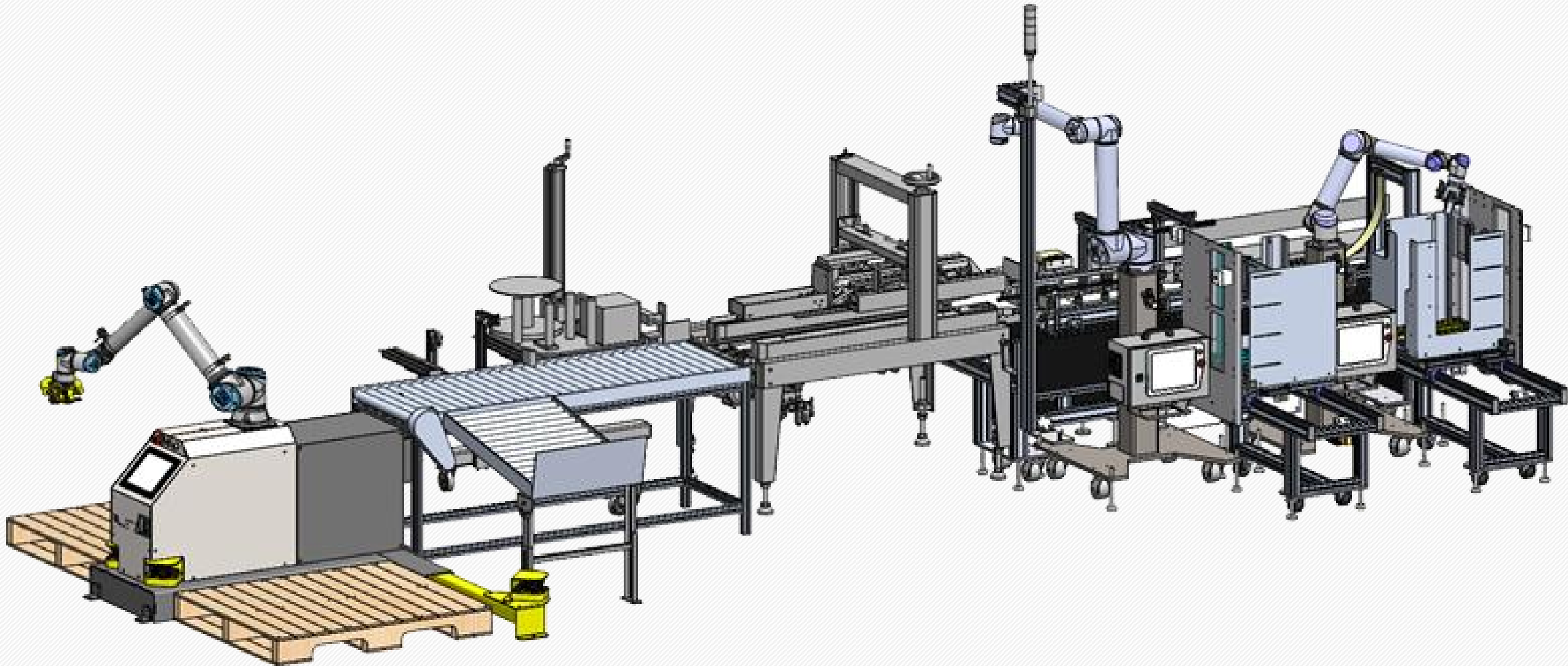

# Product development process

**EGROECO**

**The first generation  
of box maker**



**fast speed**

**Second generation  
box maker**



**small volume**

**Third generation  
box maker**



**Compatible strong**

**Fourth generation  
box maker**

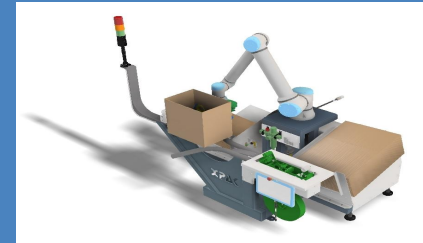

**smarter**

# Product development process

**EGROECO**

**First generation  
packing machine**



**fast speed**

**The second  
generation of  
packing machine**



**small volume**

**Third-generation  
packing machine**



**Compatible strong**

**The fourth  
generation of  
packing machine**

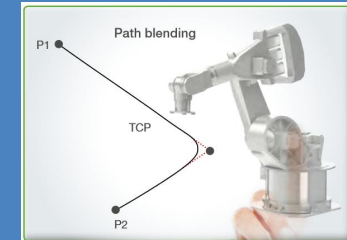

**smarter**

# Product development process

**EGROECO**

The first generation  
of palletizing  
machine



fast speed

The second  
generation  
palletizing



Compatible strong

Third generation  
streader



small volume

The fourth  
generation  
palletizing



smarter

# Series: YUKX-G



## Characteristic:

- Small footprint
- Compatibility: the robot arm span within available size box is almost compatible;
- Flexible deployment: light weight, small floor area, can be quickly deployed in different floors, different workshops;
- Simple operation: drag the instruction + graphical programming interface, ordinary operators can quickly get started;

## Product profile (Fixed position)

unpacking robot set automatic unpacking, automatic cover, automatic sealing the bottom of the carton, can adapt to different types of cartons;

Items	YUKX950-G	YUKX1300-G	Remark
Occupied area	1200*1000mm	1200*1000mm	Small footprint
Robot arm span	950mm load of 5kg	1300mm	
Power supply	220V 60HZ	220V 60HZ	
Air compressor	2 / 3L 5kgf / cm <sup>3</sup>	2 / 3L 5kgf / cm <sup>3</sup>	
Unpacking speed	6-8 pc / 1 min	6-8 pcs / 1 min	
Box range (length * width * height)	150-800mm	150-1150mm	The carton length + width must be within related arm span;
Worktop height	600-800mm	600-800mm	
Overall dimension (length * width * height)	1200 * 1000 * 800-1000mm	1400 * 1200 * 800-1000mm	
Power	240W	240W	

# Series: YUKX-M



## Characteristic:

- Small footprint
- Compatibility: the robot arm span within available size box is almost compatible;
- Flexible deployment: light weight, small floor area, can be quickly deployed in different floors, different workshops;
- Simple operation: drag the instruction + graphical programming interface, ordinary operators can quickly get started;

**Product profile(Moveable):**  
unpacking robot set automatic unpacking, automatic cover, automatic sealing the bottom of the carton, can adapt to different types of cartons;

Items	YUKX950-M	YUKX1300-M	Remark
Occupied area	1200*1000mm	1400*1200mm	Small footprint
Robot arm span	950mm load of 5kg	1300mm	
Power supply	220V 60HZ	220V 60HZ	
Air compressor	2 / 3L 5kgf / cm <sup>3</sup>	2 / 3L 5kgf / cm <sup>3</sup>	
Unpacking speed	6-8 pc / 1 min	6-8 pcs / 1 min	
Box range (length * width * height)	150-800mm	150-1150mm	The carton length + width must be within related arm span;
Worktop height	600-800mm	600-800mm	
Overall dimension (length * width * height)	1200 * 1000 * 800-1000mm	1400 * 1200 * 800-1000mm	
Power	240W	240W	



# Series: YUKX-P

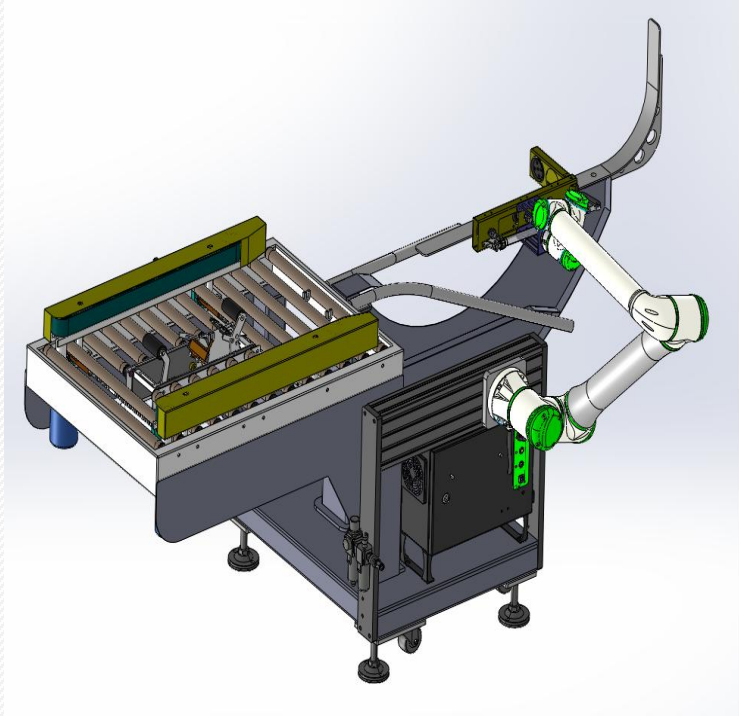

## Characteristic:

- Small footprint
- Compatibility: the robot arm span within available size box is almost compatible;
- Flexible deployment: light weight, small floor area, can be quickly deployed in different floors, different workshops;
- Simple operation: drag the instruction + graphical programming interface, ordinary operators can quickly get started;
- Beautiful bottom cover: through the belt assistance, the bottom tape sealing box is flat, middle, beautiful;
- Speed increase

## Product profile(With belt):

unpacking robot set automatic unpacking, automatic cover, automatic sealing the bottom of the carton, can adapt to different types of cartons;

Items	YUKX950-P	YUKX1300-P	Remark
Occupied area	1200*1000mm	1400*1200mm	Small footprint
Robot arm span	950mm load of 5kg	1300mm	
Power supply	220V 60HZ	220V 60HZ	
Air compressor	2 / 3L 5kgf / cm <sup>3</sup>	2 / 3L 5kgf / cm <sup>3</sup>	
Unpacking speed	8-10 pc / 1 min	8-10 pcs / 1 min	
Box range (length * width * height)	150-800mm	150-1150mm	The carton length + width must be within related arm span;
Worktop height	600-800mm	600-800mm	
Overall dimension (length * width * height)	1200 * 1000 * 800-1000mm	1400 * 1200 * 800-1000mm	
Power	240W	240W	



# Series: YUKX-Z

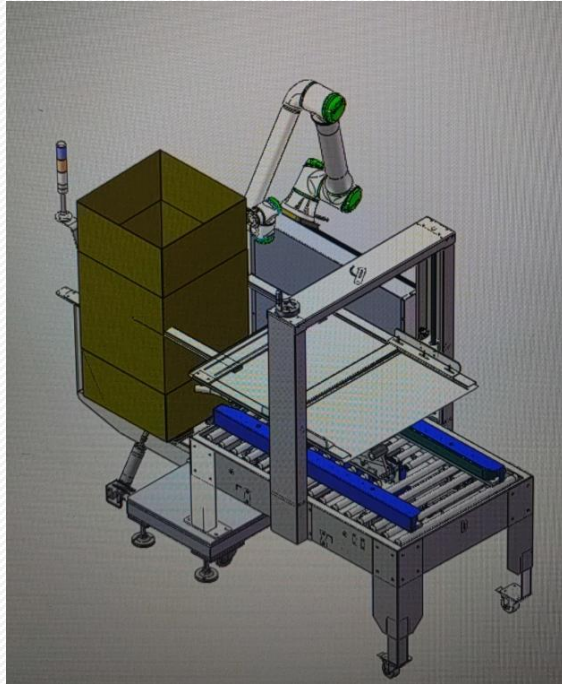

## Characteristic:

- Small footprint
- Compatibility: the robot arm span within available size box is almost compatible;
- Flexible deployment: light weight, small floor area, can be quickly deployed in different floors, different workshops;
- Simple operation: drag the instruction + graphical programming interface, ordinary operators can quickly get started;
- Beautiful bottom cover: through the belt assistance, the bottom tape sealing box is flat, middle, beautiful;
- Adaptive carton size: the belt can automatically adjust the width according to the size of the carton;

## Product profile(Self-adjustable):

unpacking robot set automatic unpacking, automatic cover, automatic sealing the bottom of the carton, can adapt to different types of cartons;

Items	YUKX950-Z	YUKX1300-Z	Remark
Occupied area	1200*1000mm	1400*1200mm	Small footprint
Robot arm span	950mm load of 5kg	1300mm	
Power supply	220V 60HZ	220V 60HZ	
Air compressor	2 / 3L 5kgf / cm <sup>3</sup>	2 / 3L 5kgf / cm <sup>3</sup>	
Unpacking speed	8-10 pc / 1 min	8-10 pcs / 1 min	
Box range (length * width * height)	150-800mm	150-1150mm	The carton length + width must be within related arm span;
Worktop height	600-800mm	600-800mm	
Overall dimension (length * width * height)	1400 * 1200 * 800-1000mm	1400 * 1200 * 800-1000mm	
Power	240W	240W	

# Standard packing machine series

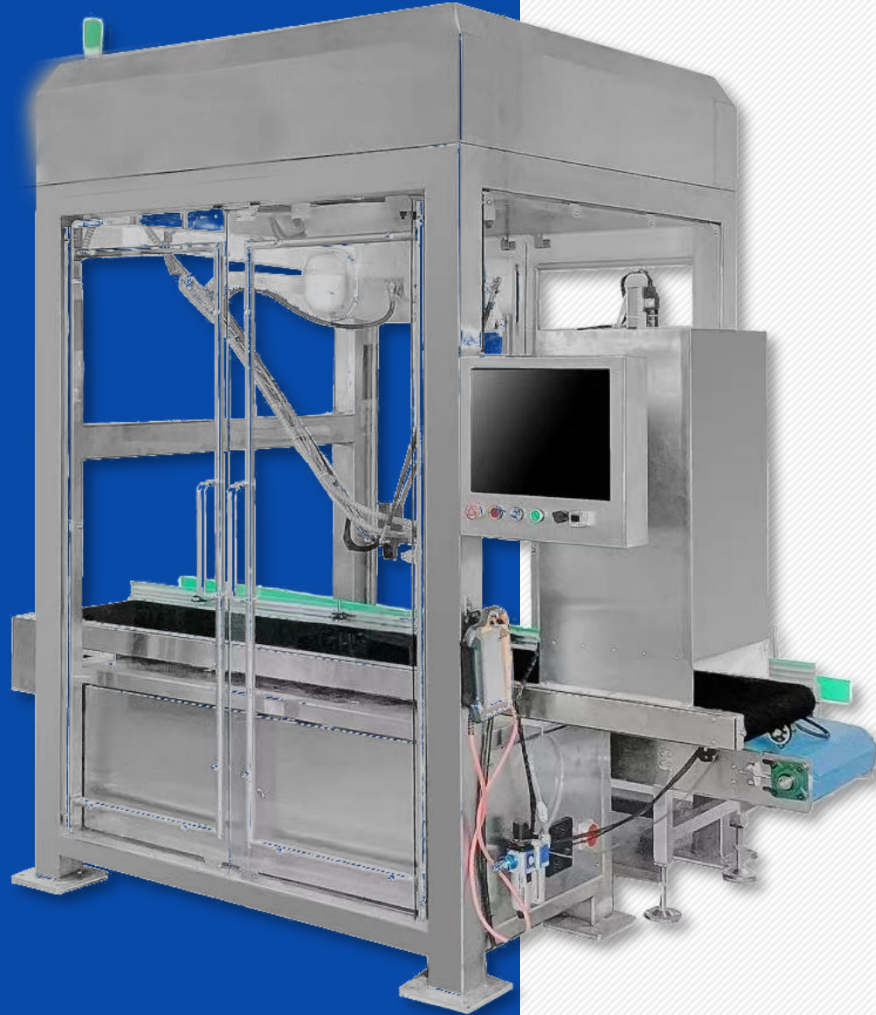

## YU -ZX1000D/1200D

### high speed performance

Maximum speed: 7.8 m / s  
Minimum cycle time: 0.35 seconds

### strong stability

Unique, high-rigid arm design  
The residual vibration is low

### Easy to use

First-class controller with  
development software

### Wide applicability

Suitable for a variety of  
applications and industries

# Series —— YU-ZX1000D / 1200D



The equipment integrates three functions of unpacking, packing and sealing, and is easy to install and use. The machine is compact, high integration, small footprint, and has the characteristics of high degree of automation, fast packing speed and high safety. Especially suitable for food, medicine and other industrial applications.

The equipment adopts advanced control technology, which greatly improves the flexibility of the equipment. Through formula management and visual design, multiple sets of different packaging schemes can be flexibly set for one-click switch, which greatly shortens the production line change time and improves work efficiency.



# Collaborative palletizing robot

## fast speed

Pelletizing 7-8 boxes / minute

## High safety

Collision detection, man-machine collaboration;  
Keep the power off

## The scope of work is wide

20kg load, stack plate height: 2,100 mm

## Strong ease of use

Simple operation, strong applicability



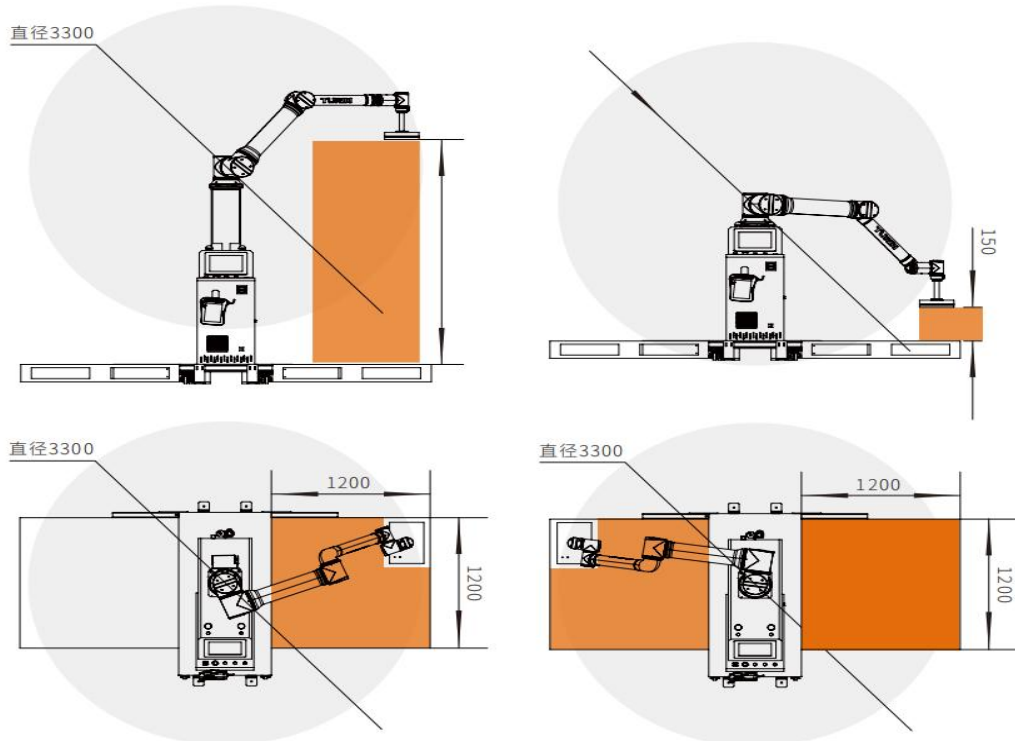

型号 Model	TPWH20
负载 Load	20kg
工作半径 Working radius	1650mm
最大托盘尺寸 Maximum tray size	1200*1200
码垛高度 Stacking height	2100mm
码垛速度 Palletizing speed	8-10 箱 /min
额定电压 Rated voltage	单相 220V
工作气压 Working air pressure	>0.5Mpa
IP等级 IP rating	IP54

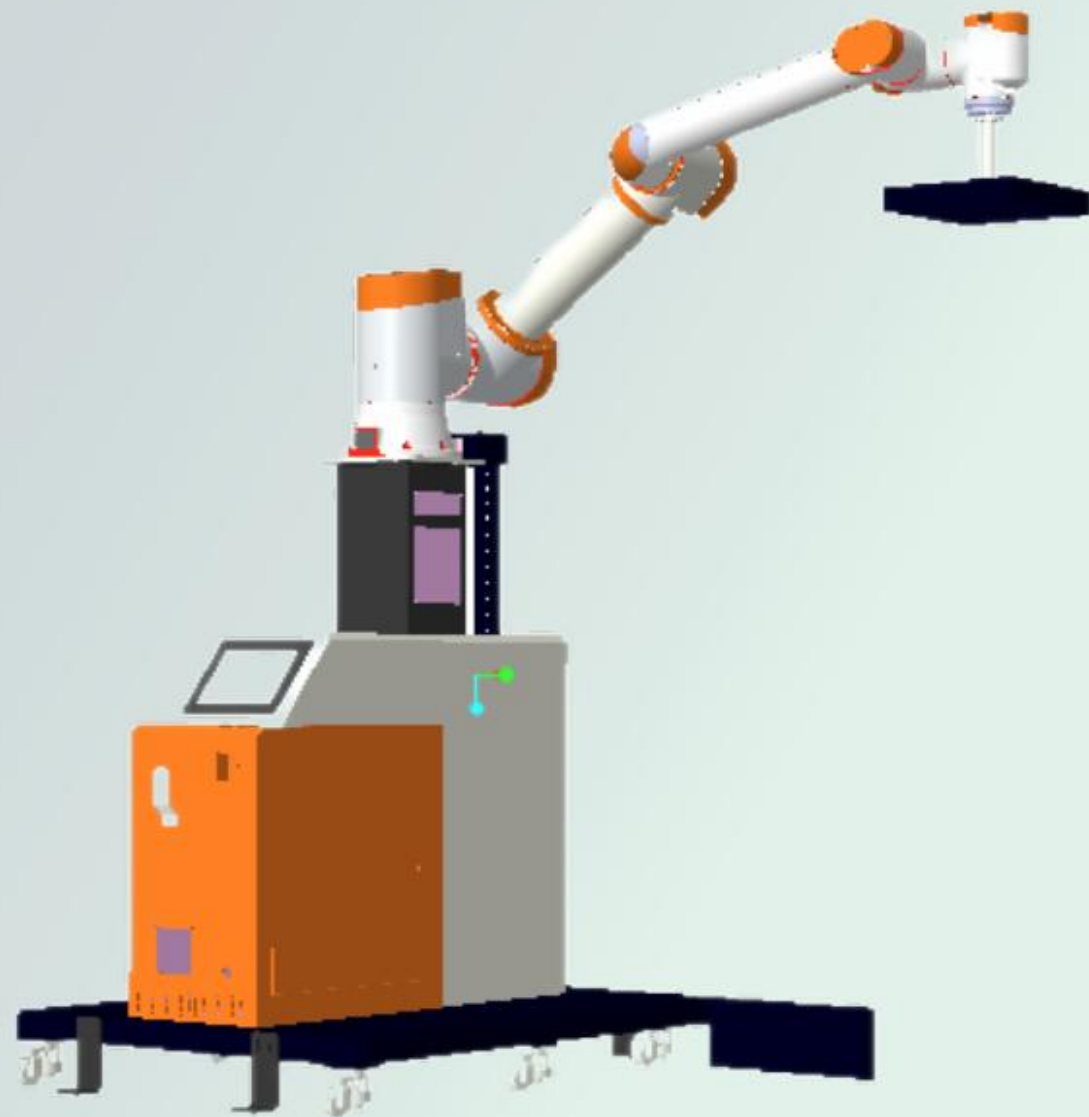
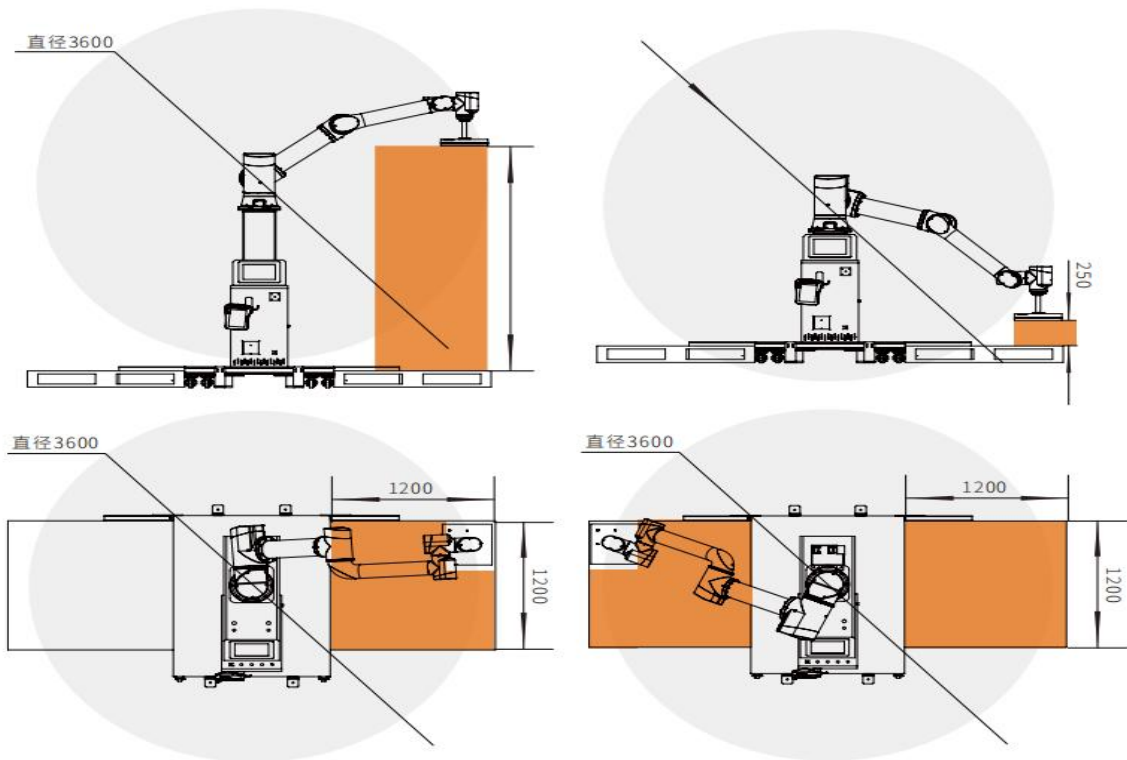

型号 Model	TPWH30
负载 Load	30kg
工作半径 Working radius	1800mm
最大托盘尺寸 Maximum tray size	1200*1200
码垛高度 Stacking height	2200mm
码垛速度 Palletizing speed	8-10 箱 /min
额定电压 Rated voltage	单相 220V
工作气压 Working air pressure	>0.5Mpa
IP等级 IP rating	IP54